

**ALL PRODUCT INDEX  
L2800DT/HST**

---

**FREQUENTLY USED ITEMS**

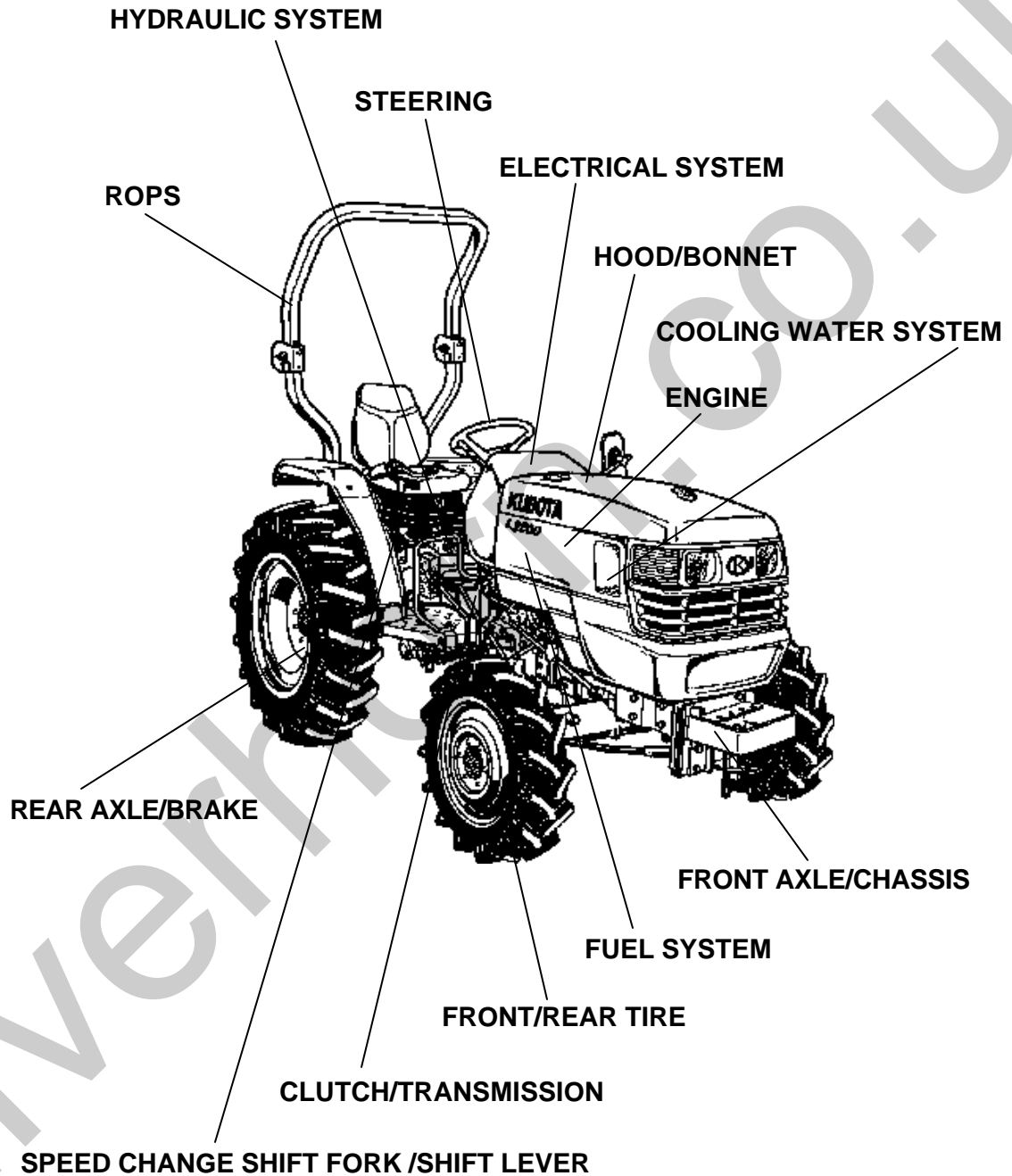

**LABELS**

**OPTION**

**3-POINT LINKAGE/DRAWBAR/HITCH**

**ACCESSORIES AND SERVICE PARTS**

Item	Part No.	Description	Book
<b>FREQUENTLY USED ITEMS</b>	000000	FREQUENTLY USED ITEMS	100K0829
<b>ENGINE</b>	01000101	CRANKCASE	100K0829
	010002	OIL PAN	100K0829
	01000301	CYLINDER HEAD	100K0829
	010004	GEAR CASE	100K0829
	010005	HEAD COVER	100K0829
	010100	MAIN BEARING CASE	100K0829
	010101	CAMSHAFT AND IDLE GEAR SHAFT	100K0829
	01010201	PISTON AND CRANKSHAFT	100K0829
	01010301	FLYWHEEL	100K0829
	010105	FUEL CAMSHAFT	100K0829
	010200	ENGINE STOP LEVER	100K0829
	010202	INJECTION PUMP	100K0829
	010204	GOVERNOR	100K0829
	010205	SPEED CONTROL PLATE	100K0829
	010206	NOZZLE HOLDER AND GLOW PLUG	100K0829
	010207	NOZZLE HOLDER [COMPONENT PARTS]	100K0829
	010500	WATER FLANGE AND THERMOSTAT	100K0829
	010501	WATER PUMP	100K0829
	010600	VALVE AND ROCKER ARM	100K0829
	010601	INLET MANIFOLD	100K0829
	010603	EXHAUST MANIFOLD/MUFFLER	100K0829
	010604	AIR CLEANER	100K0829
	01090101	UPPER GASKET KIT	100K0829
	010902	LOWER GASKET KIT	100K0829
	01A01001	ACCELERATOR LEVER [EXCEPT HST TYPE]	100K0829
	01A01002	ACCELERATOR LEVER [HST TYPE]	100K0829
	01A025	ACCELERATOR LINKAGE [EXCEPT HST TYPE]	100K0829
<b>FUEL SYSTEM</b>	01A101	FUEL TANK	100K0829
	01A11001	FUEL PIPE AND FUEL FILTER [EXCEPT HST TYPE]	100K0829
	01A11002	FUEL PIPE AND FUEL FILTER [HST TYPE]	100K0829
	01A130	FUEL FILTER [COMPONENT PARTS]	100K0829
<b>COOLING WATER SYSTEM</b>	01A401	FAN	100K0829
	01A410	WATER PIPE	100K0829
	01A42001	RADIATOR [EXCEPT HST TYPE]	100K0829
	01A42002	RADIATOR [HST TYPE]	100K0829
	01A430	RESERVE TANK [HST TYPE]	100K0829
<b>ELECTRICAL SYSTEM</b>	01A515	ALTERNATOR	100K0829
	01A520	ALTERNATOR [COMPONENT PARTS]	100K0829
	01A525	STARTER	100K0829
	01A530	STARTER [COMPONENT PARTS]	100K0829
	01A53501	BATTERY [EXCEPT HST TYPE]	100K0829
	01A53502	BATTERY [HST TYPE]	100K0829
	01B102	SWITCH/RELAY	100K0829
	01B10301	SWITCH /SENSOR [EXCEPT HST TYPE]	100K0829
	01B10302	SWITCH/SENSOR [HST TYPE]	100K0829
	01B115	PANEL BOARD	100K0829

Item	Part No.	Description	Book	
ELECTRICAL SYSTEM	01B120	PANEL BOARD [COMPONENT PARTS]	100K0829	
	01B30301	HEAD LIGHT [OLD TYPE]	100K0829	
	01B30302	HEAD LIGHT [NEW TYPE]	100K0829	
	01B311	HAZARD LIGHT	100K0829	
	01B312	REAR LAMP	100K0829	
	01B50101	ELECTRICAL WIRING [EXCEPT HST TYPE]	100K0829	
	01B50102	ELECTRICAL WIRING [HST TYPE]	100K0829	
	CLUTCH/TRANSMISSION	01C10101	CLUTCH	100K0829
		01C20101	CLUTCH LEVER [EXCEPT HST TYPE]	100K0829
		01C20103	CLUTCH LEVER [HST TYPE]	100K0829
01C301		CLUTCH PEDAL	100K0829	
01C40101		CLUTCH HOUSING [EXCEPT HST TYPE]	100K0829	
01C40103		CLUTCH HOUSING [HST TYPE]	100K0829	
01C40301		HST(INPUT SHAFT) [COMPONENT PARTS] [HST TYPE]	100K0829	
01C40302		HST(PUMP SHAFT) [COMPONENT PARTS] [HST TYPE]	100K0829	
01C40303		HST(MOTOR SHAFT) [COMPONENT PARTS] [HST TYPE]	100K0829	
01C40304		HST(VALVE) [COMPONENT PARTS] [HST TYPE]	100K0829	
01C42002		TRANSMISSION CASE [EXCEPT HST TYPE]	100K0829	
01C42003		TRANSMISSION CASE [HST TYPE]	100K0829	
01D10101		MAIN SHAFT [EXCEPT HST TYPE]	100K0829	
01D105		COUNTERSHAFT [EXCEPT HST TYPE]	100K0829	
01D116		REVERSE SHAFT [EXCEPT HST TYPE]	100K0829	
01D11701		RANGE GEAR SHAFT [EXCEPT HST TYPE]	100K0829	
01D11702		RANGE GEAR SHAFT [HST TYPE]	100K0829	
01D12502		SPIRAL BEVEL PINION [EXCEPT HST TYPE]	100K0829	
01D12503		SPIRAL BEVEL PINION [HST TYPE]	100K0829	
01D12701		REAR DIFFERENTIAL	100K0829	
01D13002	PTO COUNTERSHAFT [EXCEPT HST TYPE]	100K0829		
01D13005	PTO COUNTERSHAFT [HST TYPE]	100K0829		
01D13007	PTO COUNTERSHAFT [HST TYPE] [OLD TYPE]	100K0829		
01D13008	PTO COUNTERSHAFT [HST TYPE] [NEW TYPE]	100K0829		
01D135	PTO SHAFT	100K0829		
SPEED CHANGE SHIFT FORK /SHIFT LEVER	01D201	MAIN GEAR SHIFT FORK [EXCEPT HST TYPE]	100K0829	
	01D21701	RANGE GEAR SHIFT FORK [EXCEPT HST TYPE]	100K0829	
	01D21702	RANGE GEAR SHIFT FORK [HST TYPE]	100K0829	

Item	Part No.	Description	Book	
SPEED CHANGE SHIFT FORK /SHIFT LEVER	01D22001	PTO GEAR SHIFT FORK [EXCEPT HST TYPE]	100K0829	
	01D22501	DIFFERENTIAL LOCK SHIFT FORK [EXCEPT HST TYPE]	100K0829	
	01D22502	DIFFERENTIAL LOCK SHIFT FORK [HST TYPE]	100K0829	
	01E101	MAIN GEAR SHIFT LEVER [EXCEPT HST TYPE]	100K0829	
	01E106	CRUISE CONTROL LEVER [HST TYPE]	100K0829	
	01E107	CRUISE CONTROL CABLE [HST TYPE]	100K0829	
	01E108	NEUTRAL HOLDER ARM [HST TYPE]	100K0829	
	01E109	SPEED CONTROL PEDAL [HST TYPE]	100K0829	
	01E11001	RANGE GEAR SHIFT LEVER [EXCEPT HST TYPE]	100K0829	
	01E11002	RANGE GEAR SHIFT LEVER [HST TYPE]	100K0829	
	01E112	RANGE GEAR SHIFT ROD [EXCEPT HST TYPE]	100K0829	
	01E125	PTO GEAR SHIFT LEVER [EXCEPT HST TYPE]	100K0829	
	01E126	PTO CLUTCH CONTROL LEVER [HST TYPE]	100K0829	
	01E14001	FRONT WHEEL DRIVE LEVER [EXCEPT HST TYPE]	100K0829	
	01E14002	FRONT WHEEL DRIVE LEVER [HST TYPE]	100K0829	
	REAR AXLE/BRAKE	01E150	REAR AXLE	100K0829
		01E16001	BRAKE [EXCEPT HST TYPE]	100K0829
		01E16002	BRAKE [HST TYPE]	100K0829
		01E20101	BRAKE PEDAL [EXCEPT HST TYPE]	100K0829
01E20102		BRAKE PEDAL [HST TYPE]	100K0829	
01E202		PARKING BRAKE LEVER	100K0829	
FRONT AXLE/CHASSIS	01F10502	FRONT AXLE FRAME [EXCEPT HST TYPE]	100K0829	
	01F10503	FRONT AXLE FRAME [HST TYPE]	100K0829	
	01F120	PROPELLER SHAFT	100K0829	
	01F122	FRONT WHEEL DRIVE SHAFT	100K0829	
	01F125	FRONT DIFFERENTIAL CASE	100K0829	
	01F135	FRONT DIFFERENTIAL	100K0829	
	01F141	FRONT AXLE CASE LH	100K0829	
	01F142	FRONT AXLE CASE RH	100K0829	
	01F145	DIFFERENTIAL GEAR SHAFT	100K0829	
	01F150	FRONT AXLE	100K0829	
	STEERING	01G101	STEERING HANDLE	100K0829
		01G105	UNIVERSAL JOINT	100K0829
		01G10702	STEERING	100K0829
		01G112	STEERING [COMPONENT PARTS]	100K0829
		01G12002	STEERING LINKAGE (TIE ROD)	100K0829
HYDRAULIC SYSTEM	01H120	HYDRAULIC PUMP	100K0829	
	01H125	HYDRAULIC PUMP [COMPONENT PARTS]	100K0829	

Item	Part No.	Description	Book	
HYDRAULIC SYSTEM	01H20501	HYDRAULIC OIL LINE(INLET) [EXCEPT HST TYPE]	100K0829	
	01H20502	HYDRAULIC OIL LINE(INLET) [HST TYPE]	100K0829	
	01H210	HYDRAULIC OIL LINE(DELIVERY)	100K0829	
	01H22501	HYDRAULIC OIL LINE(POWER STEERING) [EXCEPT HST TYPE]	100K0829	
	01H22502	HYDRAULIC OIL LINE(POWER STEERING) [HST TYPE]	100K0829	
	01H23501	HYDRAULIC OUTLET BLOCK [EXCEPT HST TYPE]	100K0829	
	01H23502	HYDRAULIC OUTLET BLOCK [HST TYPE]	100K0829	
	01H240	HYDRAULIC PIPE(HST) [HST TYPE]	100K0829	
	01H245	OIL COOLER [HST TYPE]	100K0829	
	01H301	HYDRAULIC CYLINDER	100K0829	
	01H303	CYLINDER FRONT COVER	100K0829	
	01H320	LIFT ARM	100K0829	
	01H330	FEED BACK LEVER	100K0829	
	01H405	CONTROL VALVE [OLD TYPE]	100K0829	
	01H40501	CONTROL VALVE [NEW TYPE]	100K0829	
	01H410	CONTROL VALVE [COMPONENT PARTS] [OLD TYPE]	100K0829	
	01H41001	CONTROL VALVE [COMPONENT PARTS] [NEW TYPE]	100K0829	
	01H440	POSITION CONTROL LEVER	100K0829	
	3-POINT LINKAGE/DRAWBAR/HITCH	01J105	TOP LINK	100K0829
		01J110	3-POINT LINKAGE 1 (LOWER LINK)	100K0829
01J115		3-POINT LINKAGE 2 (LIFT ROD)	100K0829	
01K105		DRAWBAR	100K0829	
01K125		PTO PROTECTOR	100K0829	
HOOD/BONNET	01L101	FRONT GRILLE	100K0829	
	01L10201	HOOD(BONNET) FRONT SUPPORT [EXCEPT HST TYPE]	100K0829	
	01L10202	HOOD(BONNET) FRONT SUPPORT [HST TYPE]	100K0829	
	01L105	HOOD(BONNET)	100K0829	
	01L110	HOOD(BONNET) SIDE	100K0829	
	01L120	HOOD(BONNET) SIDE COVER	100K0829	
	01L13001	SHUTTER PLATE [EXCEPT HST TYPE]	100K0829	
	01L13002	SHUTTER PLATE [HST TYPE]	100K0829	
	01L135	HOOD(BONNET) REAR	100K0829	
	01L210	FENDER	100K0829	
	01L21301	FENDER SUPPORT [EXCEPT HST TYPE]	100K0829	
	01L21302	FENDER SUPPORT [HST TYPE]	100K0829	
	01L21701	FLOOR SEAT COVER [EXCEPT HST TYPE]	100K0829	
	01L21702	FLOOR SEAT COVER [HST TYPE]	100K0829	
	01L220	SEAT	100K0829	
01L22501	STEP [EXCEPT HST TYPE]	100K0829		
01L22502	STEP [HST TYPE]	100K0829		

Item	Part No.	Description	Book
ROPS	01L30101	ROPS (RIGID TYPE)	100K0829
	01L30102	ROPS (FOLDABLE TYPE)	100K0829
HOOD/BONNET FRONT/REAR TIRE	01L501	SMV EMBLEM	100K0829
	01P10102	FRONT WHEEL (7-16)	100K0829
	01P10104	FRONT WHEEL (25*8.50-14)	100K0829
	01P10105	FRONT WHEEL (27*8.50-15)	100K0829
	01P11001	REAR WHEEL (11.2-24)	100K0829
	01P11002	REAR WHEEL (13.6-16)	100K0829
	01P11003	REAR WHEEL (15-19.5)	100K0829
LABELS	01R10501	LABEL 1 (FRONT) [EXCEPT HST TYPE]	100K0829
	01R10502	LABEL 1 (FRONT) [HST TYPE]	100K0829
	01R11002	LABEL 2 (REAR) [EXCEPT HST TYPE]	100K0829
ACCESSORIES AND SERVICE PARTS OPTION	01R11003	LABEL 2 (REAR) [HST TYPE]	100K0829
	01S105	ACCESSORIES AND SERVICE PARTS	100K0829
	01T105	WORKING LIGHT KIT(W/G No.M9551) [OPTION]	100K0829
	01T121	FRONT BUMPER(W/G No.MX8068) [OPTION]	100K0829
	01T122	FRONT WEIGHT [OPTION]	100K0829
	01T123	REAR WHEEL WEIGHT [OPTION]	100K0829
	01T127	CONTROL VALVE (WITH DRAFT) [OPTION]	100K0829
	01T128	CONTROL VALVE (WITH DRAFT) [COMPONENT PARTS] [OPTION]	100K0829
	01T135	DRAFT CONTROL LEVER (WITH DRAFT) [OPTION]	100K0829
	01T136	DRAFT CONTROL VALVE (WITH DRAFT) [COMPONENT PARTS] [OPTION]	100K0829
	01T140	TOP LINK HOLDER (WITH DRAFT) [OPTION]	100K0829
	01T143	STABILIZER(W/G No.L8430) [OPTION]	100K0829
	01T144	SWINGING DRAWBAR [OPTION]	100K0829
	01T148	T/M OIL EXTENSION PORT AND GAUGE KIT	100K0829

CRANKCASE

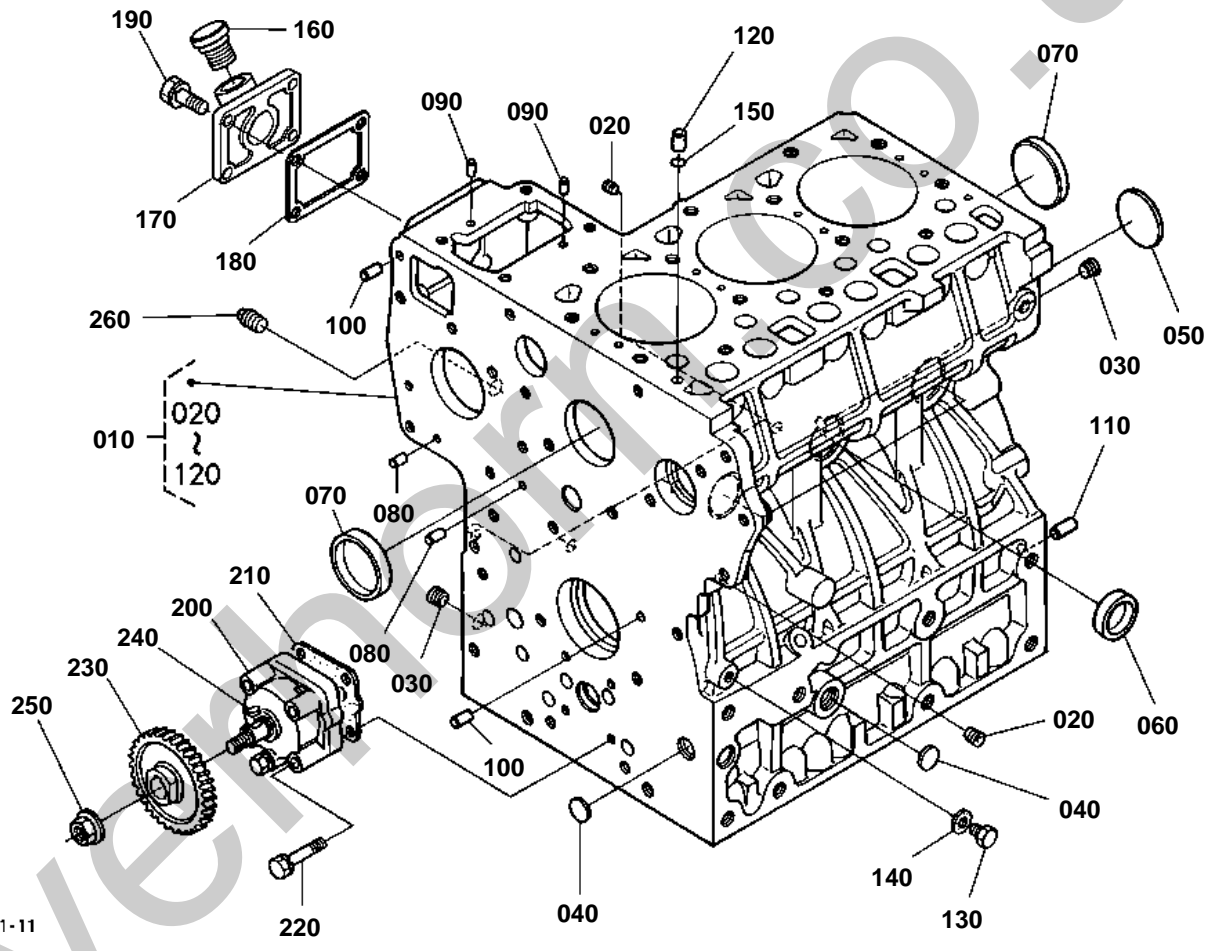

1G703-001-11

**CRANKCASE**

↔ Interchangeable; ≠ not interchangeable; ← new for old; → old for new

REF.No	Part No.	Description	Q'ty	S.No.	I/C	REMARKS	Weight (kgf)	Weight (lb)
010	1G703-01010	COMP.CRANKCASE	1				48.5	106.7
020	15521-96020	PLUG	5				0.003	0.0066
030	15521-96030	PLUG	2				0.007	0.0154
040	17391-96160	PLUG EXPANSION	3				0.003	0.0066
050	16271-96160	PLUG EXPANSION	1				0.025	0.055
060	15221-03380	CAP SEALING	5				0.017	0.0374
070	15221-03390	CAP SEALING	2				0.03	0.066
080	05012-00408	PIN STRAIGHT	2				0.001	0.0022
090	05012-00609	PIN STRAIGHT	2				0.003	0.0066
100	05012-00612	PIN STRAIGHT	2				0.003	0.0066
110	05012-01018	PIN STRAIGHT	1				0.012	0.0264
120	15221-33650	PIN PIPE	1				0.004	0.0088
130	15221-33610	PLUG	1				0.009	0.0198
130	15469-33610	PLUG	1			«	0.008	0.0176
140	15021-33660	GASKET	1				0.001	0.0022
150	15221-33700	O RING	1				0.001	0.0022
160	16427-33140	PLUG OIL FILLER	1	≤5C0845			0.025	0.055
160	16427-33142	PLUG OIL FILLER	1	≥5E0001	↔		0.025	0.055
170	1A021-33110	FLANGE OIL FILLER	1				0.07	0.154
180	1A021-51660	GASKET PUMP COVER	1				0.003	0.0066
190	01023-50618	BOLT	4				0.006	0.0132
200	15471-35013	ASSY PUMP OIL	1				0.55	1.21
210	1A021-35150	GASKET OIL PUMP	1				0.001	0.0022
220	01023-60650	BOLT	4				0.015	0.033
230	19202-35660	GEAR OIL PUMP DRIVE	1				0.23	0.506
240	05712-00410	KEY FEATHER	1				0.001	0.0022
250	15221-35682	NUT FLANGE	1				0.014	0.0308
260	06312-10020	PLUG	1				0.016	0.0352



OIL PAN

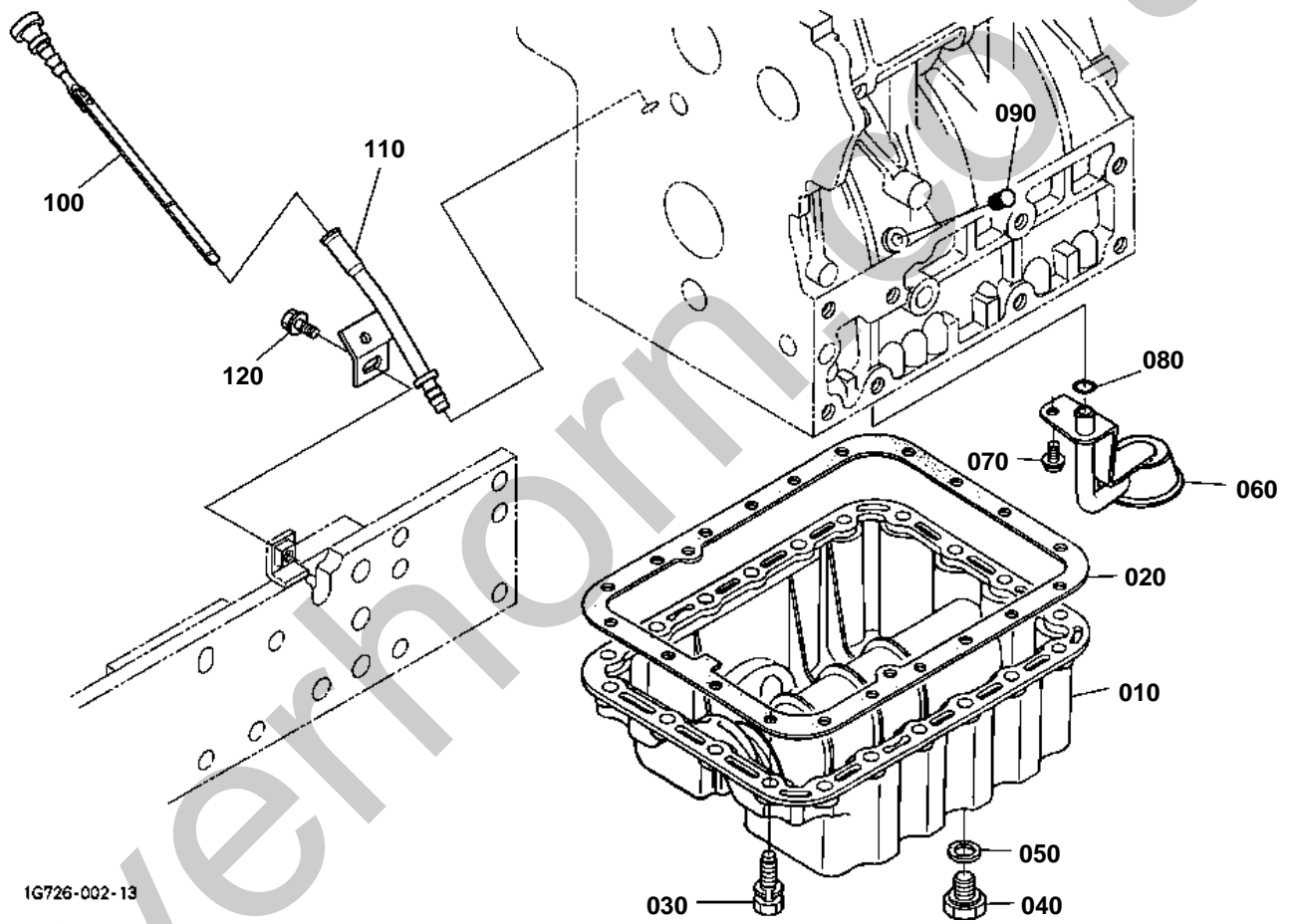

# OLD PARTS

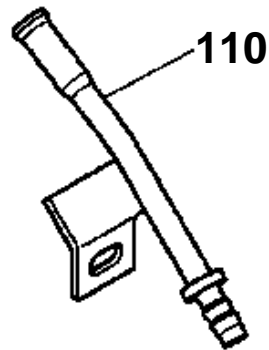
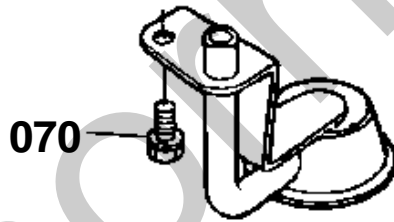
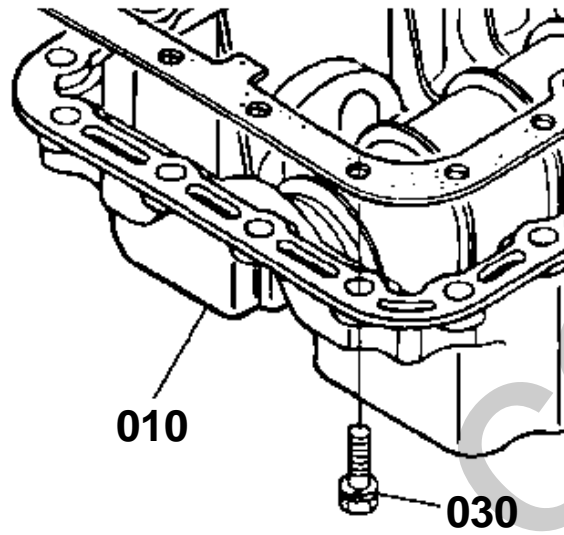

1G726-810-13



# OIL PAN

↔ Interchangeable; ≠ not interchangeable; ← new for old; → old for new

REF.No	Part No.	Description	Q'ty	S.No.	I/C	REMARKS	Weight (kgf)	Weight (lb)
010	15521-01610	OIL PAN	1	<=5E0875			2.8	6.16
010	15521-01614	OIL PAN	1	>=5G0001	-		2.8	6.16
020	1A021-01620	GASKET OIL PAN	1				0.014	0.0308
030	01133-51028	BOLT	20	<=5Q0646			0.027	0.0594
030	1A091-91010	BOLT	20	>=5S0001	-		0	0
040	16427-33750	PLUG DRAIN	2				0.03	0.066
050	6C090-58960	GASKET	2				0.002	0.0044
060	16427-32110	FILTER OIL	1				0.2	0.44
070	01123-60814	BOLT	1	<=5U0960			0.01	0.022
070	01754-50812	BOLT FLANGE	1	>=5W0001	-		0.01	0.022
080	04817-00160	O RING	1				0.001	0.0022
090	16414-33640	PLUG OIL GAUGE	1				0	0
090	1G513-36550	PLUG OIL GAUGE	1		«		0	0
100	T1060-16602	GAUGE OIL	1				0.015	0.033
110	TD060-16612	GUIDE OIL GAUGE	1	<=5E0875			0.075	0.165
110	TD060-16614	GUIDE OIL GAUGE	1	>=5G0001	-		0.075	0.165
120	01754-50816	BOLT FLANGE	1				0.011	0.0242

CYLINDER HEAD

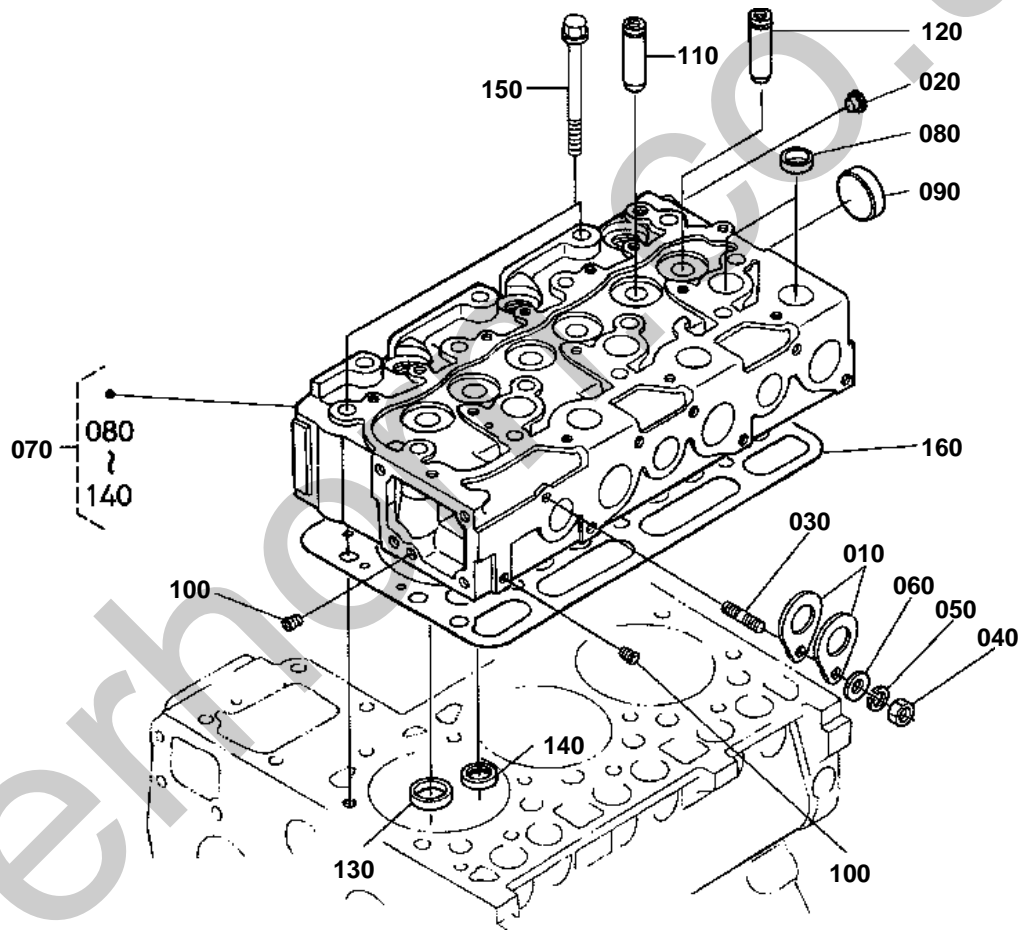

1G703-002-10



# CYLINDER HEAD

↔ Interchangeable; ≠ not interchangeable; ← new for old; → old for new

REF.No	Part No.	Description	Q'ty	S.No.	I/C	REMARKS	Weight (kgf)	Weight (lb)
010	15221-01750	HOOK ENGINE	2				0.04	0.088
020	09980-10075	CAP PROTECTOR	1				0.001	0.0022
030	15471-91530	STUD	1				0.01	0.022
040	02156-50080	NUT	1				0.004	0.0088
050	04512-60080	WASHER SPRING	1				0.002	0.0044
060	04012-50080	WASHER PLAIN	1				0.001	0.0022
070	1A002-03042	COMP.CYLINDER HEAD	1	<=4L0718			15	33
070	1A002-03043	COMP.CYLINDER HEAD	1	>=4N0001	↔		15	33
080	15221-03370	CAP SEALING	9				0.01	0.022
090	15221-03490	CAP SEALING	1				0.02	0.044
100	15261-96010	PLUG	2				0.002	0.0044
110	17321-13580	GUIDE INLET VALVE	3				0.015	0.033
120	17321-13560	GUIDE EXHAUST VALVE	3				0.02	0.044
120	1C010-13560	GUIDE VALVE EXHAUST	3		<<		0.025	0.055
130	16415-13620	SEAT INLET VALVE	3				0.01	0.022
140	16415-13612	SEAT EXHAUST VALVE	3				0.01	0.022
150	19013-03450	BOLT CYLINDER HEAD	14				0.077	0.1694
160	16427-03310	GASKET CYLINDER HEAD	1				0.11	0.242

GEAR CASE

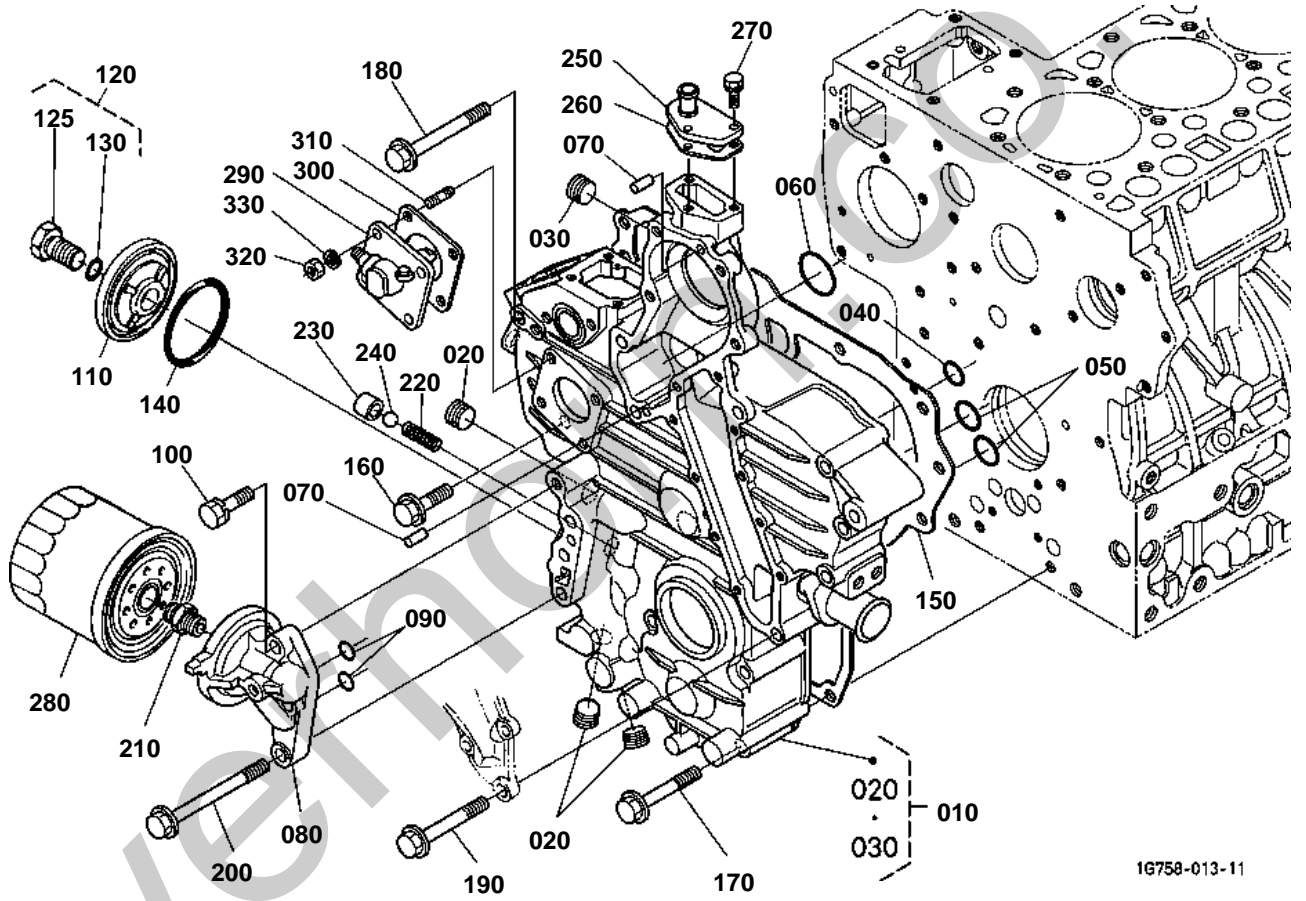

16758-013-11

# OLD PARTS

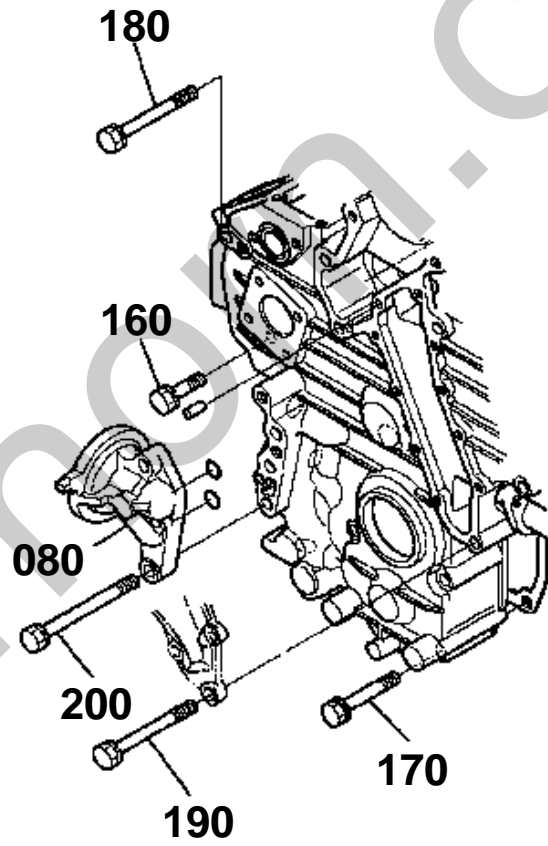
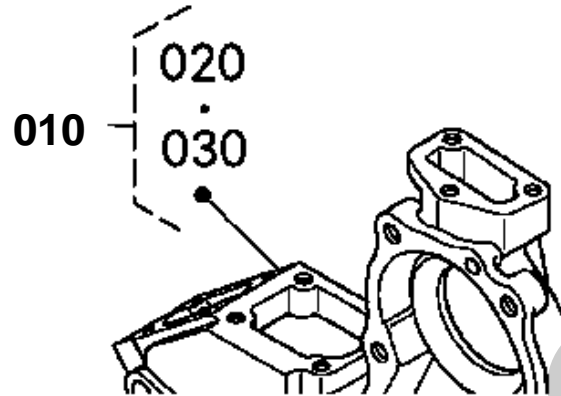

1G726-804-11



## GEAR CASE

↔ Interchangeable; ≠ not interchangeable; ← new for old; → old for new

REF.No	Part No.	Description	Q'ty	S.No.	I/C	REMARKS	Weight (kgf)	Weight (lb)
010	1A033-04022	COMP.CASE GEAR	1	<=4N0605			3.8	8.36
010	1A033-04024	COMP.CASE GEAR	1	>=4Q0001	-		3.8	8.36
010	1A033-04025	COMP.CASE GEAR	1	>=5L0001	-		3.8	8.36
020	16241-96020	PLUG	3				0.015	0.033
030	1A021-96020	PLUG	1				0.015	0.033
040	04817-00150	O RING	1				0.001	0.0022
050	04817-00220	O RING	2				0.001	0.0022
060	04817-00360	O RING	1				0.001	0.0022
070	05012-00612	PIN STRAIGHT	2				0.003	0.0066
080	1A021-32610	BASE OIL FILTER	1				0.25	0.55
080	1G742-32610	BASE OIL FILTER	1	<=4W0957	<<		0.245	0.539
080	1G801-32610	BASE OIL FILTER	1	>=5A0001	1		0.245	0.539
090	04817-00150	O RING	2				0.001	0.0022
100	01123-50835	BOLT	1				0.02	0.044
110	17331-32880	COVER	1				0.075	0.165
120	17331-32910	COMP BOLT	1				0.07	0.154
125	17331-32900	BOLT	1				0.06	0.132
130	04817-00150	O RING	1				0.001	0.0022
140	19202-96830	O RING	1				0.01	0.022
150	1A021-04130	GASKET GEAR CASE	1				0.019	0.0418
160	01123-50835	BOLT	1	<=5U0960			0.02	0.044
160	01754-50830	BOLT FLANGE	1	>=5W0001	-		0.05	0.11
170	01123-50870	BOLT	7	<=5U0960			0.029	0.0638
170	1A021-91030	BOLT FLANGE	7	>=5W0001	-		0	0
180	17367-91010	BOLT	2	<=5U0960			0.005	0.011
180	01754-50875	BOLT FLANGE	2	>=5W0001	-		0.03	0.066
190	17367-91020	BOLT	3	<=5U0960			0.035	0.077
190	01754-50885	BOLT FLANGE	3	>=5W0001	-		0.032	0.0704
200	1A021-91010	BOLT	2	<=5U0960			0.045	0.099
200	1A021-91040	BOLT FLANGE	2	>=5W0001	-		0	0
210	15521-32293	JOINT PIPE	1				0	0
210	1A021-32290	JOINT PIPE	1		<<		0.05	0.11
220	15241-36950	SPRING	1				0.004	0.0088
230	15521-36930	SEAT VALVE	1				0.015	0.033
240	07715-03213	BALL	1				0.004	0.0088
250	15521-73320	FLANGE WATER RETURN	1				0.04	0.088
260	1A021-73330	GASKET RETURN FLANGE	1				0.001	0.0022
270	01023-50620	BOLT	3				0.006	0.0132
280	16414-32430	CARTRIDGE OIL FILTER	1				0.54	1.188
290	38240-34660	ASSY GEAR CASE H/M	1				0.335	0.737
300	1G751-88130	GASKET HOUR METER	1				0.001	0.0022
310	15221-88210	STUD	4				0.005	0.011
320	02056-50060	NUT	4				0.002	0.0044
330	04512-60060	WASHER SPRING	4				0.001	0.0022



HEAD COVER

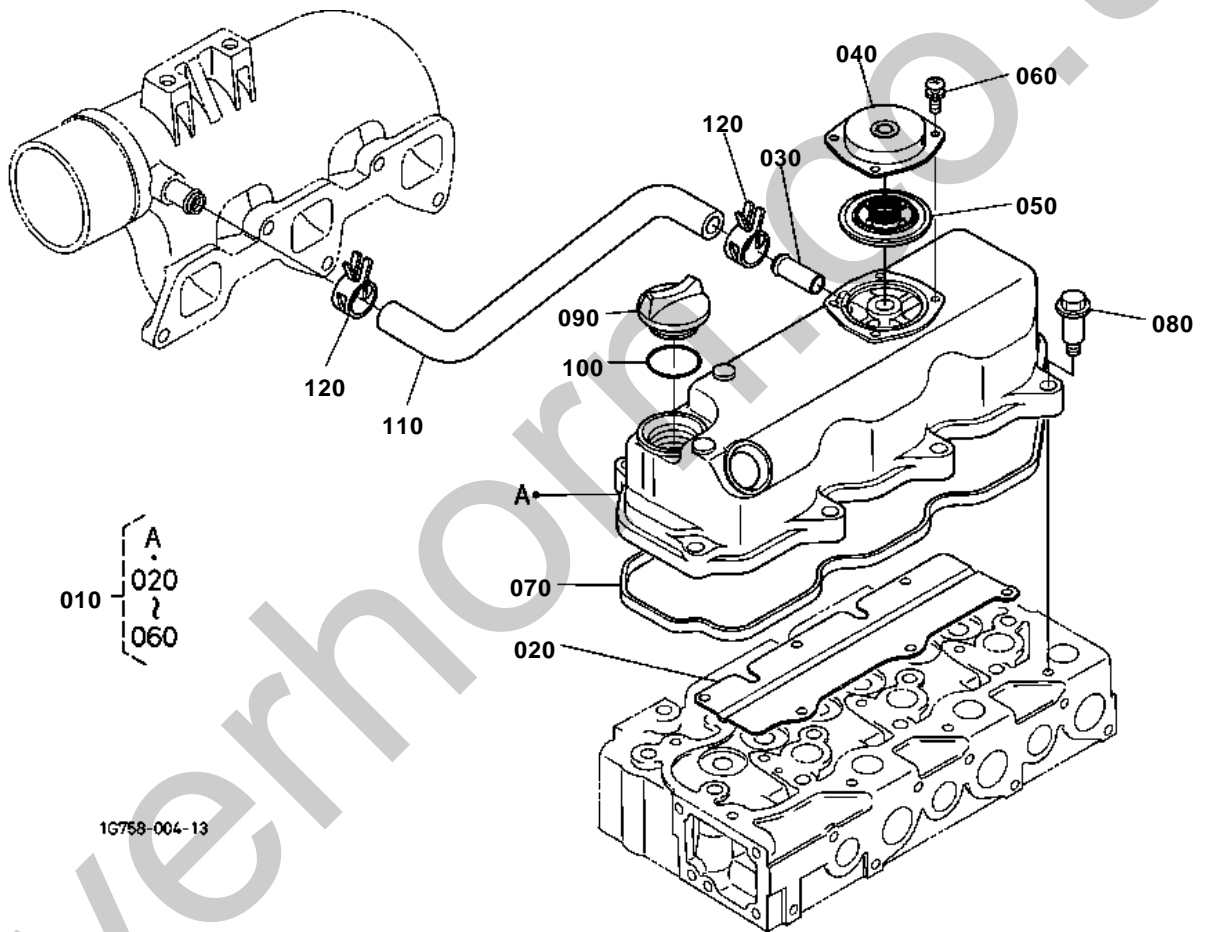

1G758-004-13

OLD PARTS

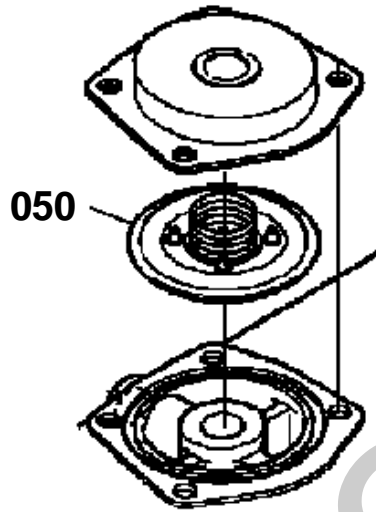

1G814-800-10

**HEAD COVER**

↔ Interchangeable; ≠ not interchangeable; ← new for old; → old for new

REF.No	Part No.	Description	Q'ty	S.No.	I/C	REMARKS	Weight (kgf)	Weight (lb)
010	1G750-14503	ASSY COVER CYL.HEAD	1	<=4J0878			0	0
010	1G750-14504	ASSY COVER CYL.HEAD	1	>=4L0001	-		1.23	2.706
010	1G750-14506	ASSY COVER CYL.HEAD	1	>=5G0001	-		1.23	2.706
020	1A021-05370	SHIELD BREATHER	1				0.1	0.22
030	17331-73342	PIPE WATER RETURN	1				0.01	0.022
040	1G911-05122	COVER BREATHER	1				0	0
040	1G801-05120	COVER BREATHER	1		«		0.035	0.077
050	1G911-05200	COMP.VALVE BREATHER	1	<=4J0878			0	0
050	1G911-05202	COMP.VALVE BREATHER	1	>=4L0001	-		0	0
050	1G911-05203	COMP.VALVE BREATHER	1	>=5G0001	-		0.01	0.022
060	03024-50510	SCREW WITH WASHER	4				0.002	0.0044
070	1A021-14520	GASKET HEAD COVER	1	<=4Y0983			0	0
070	1A021-14523	GASKET HEAD COVER	1	>=5A0001	-		0	0
080	1G911-91022	BOLT	8				0.015	0.033
090	15852-33140	PLUG OIL FILLER	1				0.038	0.0836
100	04817-50300	O RING	1				0.001	0.0022
110	1G780-05510	TUBE BREATHER	1				0.06	0.132
120	09318-88180	CLAMP HOSE	2				0.01	0.022

MAIN BEARING CASE

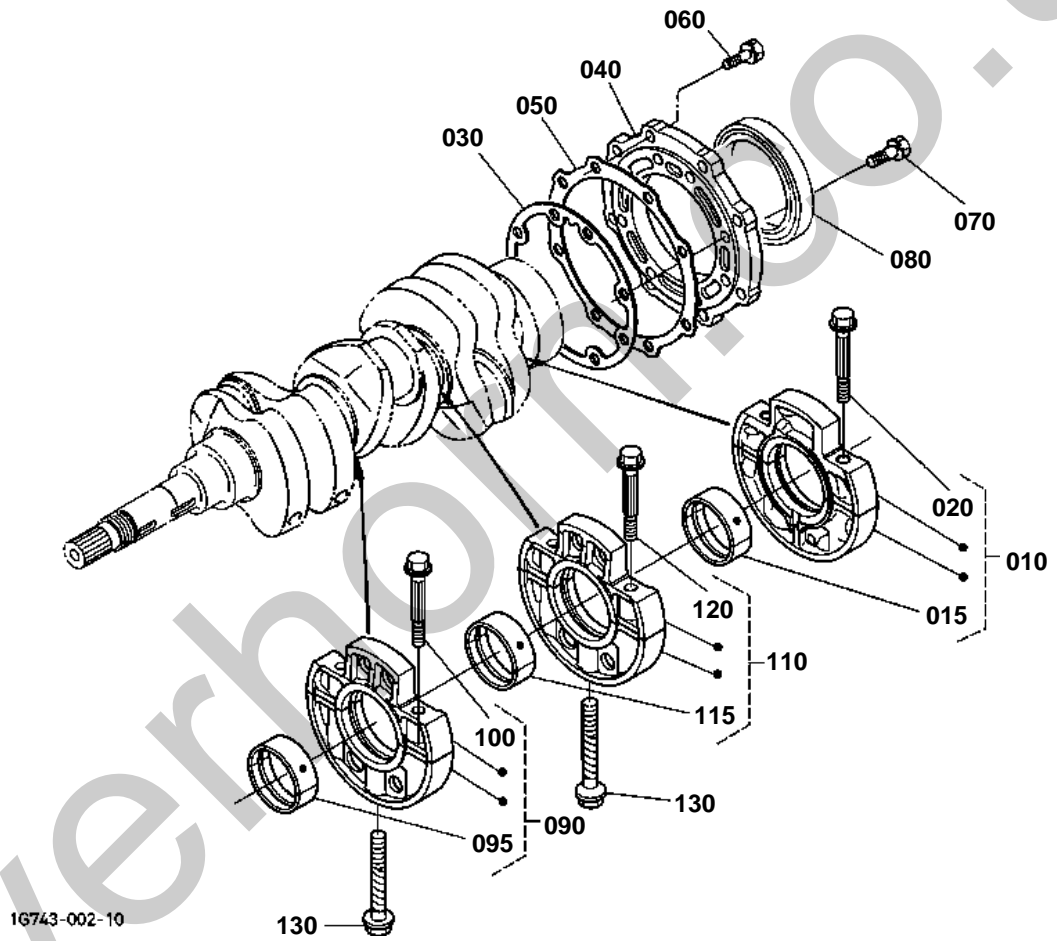



# MAIN BEARING CASE

↔ Interchangeable; ≠ not interchangeable; ← new for old; → old for new

REF.No	Part No.	Description	Q'ty	S.No.	I/C	REMARKS	Weight (kgf)	Weight (lb)
010	1A041-07093	ASSY BRG.CASE WHEEL	1				1.34	2.948
015	1A091-23480	METAL CRANKSHAFT	1			STD/SET	0.05	0.11
020	1A091-04540	BOLT BEARING CASE	2				0.035	0.077
030	1A091-04362	GASKET BEARING CASE	1				0.005	0.011
040	1G851-04810	COVER BEARING CASE	1	<=4W0957			0.495	1.089
040	1G851-04812	COVER BEARING CASE	1	>=4Y0001	-		0.495	1.089
050	1A091-04820	GASKET CASE COVER	1				0.006	0.0132
060	01123-50825	BOLT	8				0.013	0.0286
070	01123-50828	BOLT	8				0.014	0.0308
080	19202-04460	SEAL OIL	1				0.055	0.121
090	1A091-07043	ASSY BRG.CASE MAIN	1				1.34	2.948
095	1A091-23480	METAL CRANKSHAFT	1			STD/SET	0.05	0.11
100	1A091-04540	BOLT BEARING CASE	2				0.035	0.077
110	1A091-07053	ASSY BRG.CASE MAIN	1				1.34	2.948
115	1A091-23480	METAL CRANKSHAFT	1			STD/SET	0.05	0.11
120	1A091-04540	BOLT BEARING CASE	2				0.035	0.077
130	15601-04560	BOLT BEARING CASE	2				0.06	0.132

CAMSHAFT AND IDLE GEAR SHAFT

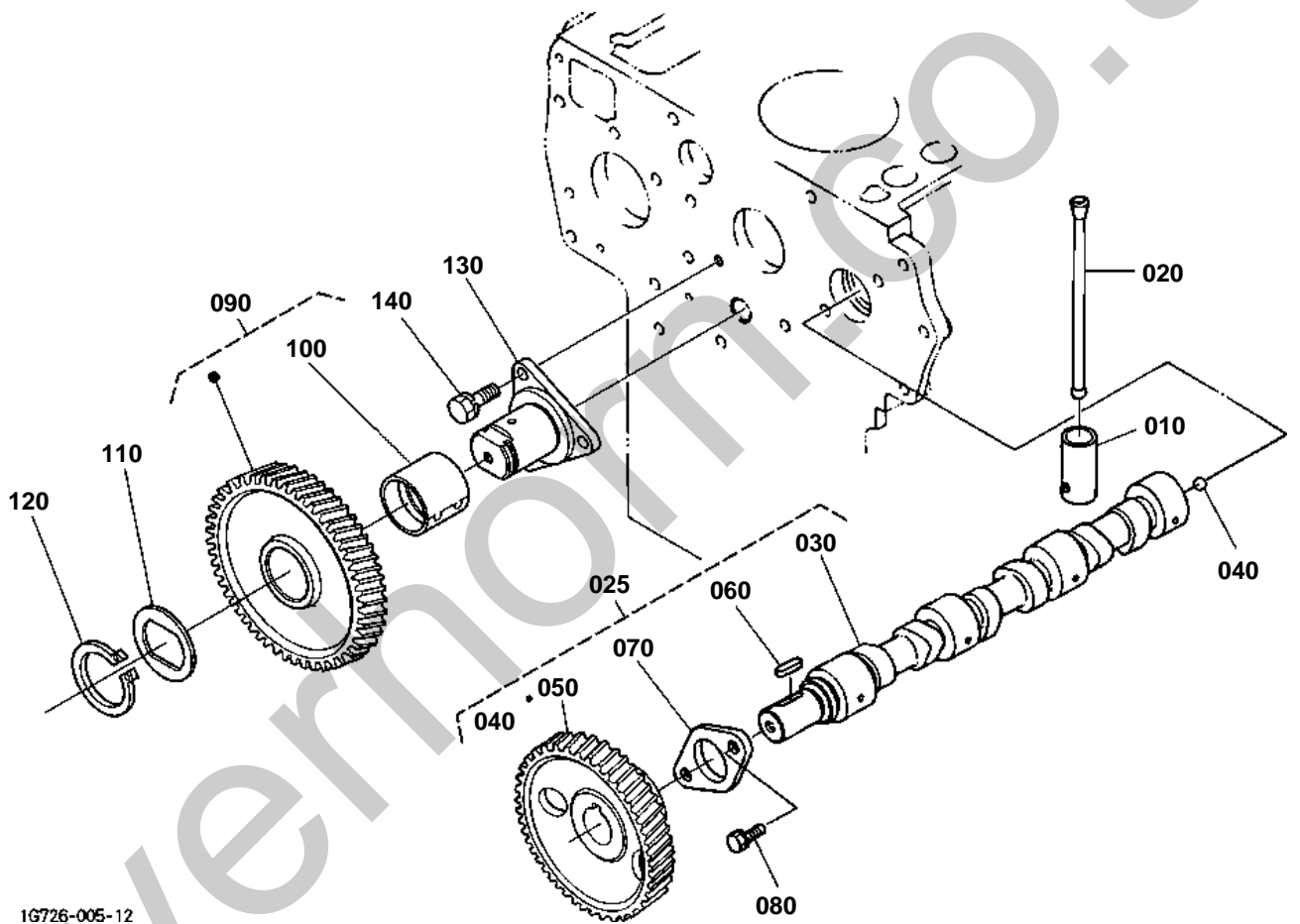

1G726-005-12



# CAMSHAFT AND IDLE GEAR SHAFT

↔ Interchangeable; ≠ not interchangeable; ← new for old; → old for new

REF.No	Part No.	Description	Q'ty	S.No.	I/C	REMARKS	Weight (kgf)	Weight (lb)
010	15601-15550	TAPPET	6				0.08	0.176
020	19013-15110	PUSH ROD	6				0.05	0.11
025	1A021-16010	ASSY CAMSHAFT	1				0	0
030	17331-16155	CAMSHAFT	1			NOT SALE	1.795	3.949
040	07715-00401	BALL	1				0.001	0.0022
050	1A091-16513	GEAR CAM	1				0.8	1.76
060	05712-00720	KEY FEATHER	1				0.008	0.0176
070	15221-16270	STOPPER CAMSHAFT	1				0.073	0.1606
080	01123-50818	BOLT	2				0.012	0.0264
090	1A091-24010	COMP.GEAR IDLE	1				1.21	2.662
100	1A021-24980	BUSH IDLE GEAR	1				0.072	0.1584
110	1A021-24370	COLLAR	1				0.022	0.0484
120	15451-95400	CIR CLIP EXTERNAL	1				0.01	0.022
130	1A021-24250	SHAFT IDLE GEAR	1	<=4Y0983			0.685	1.507
130	1A021-24252	SHAFT IDLE GEAR	1	>=5A0001	→		0.685	1.507
140	01123-50818	BOLT	3				0.012	0.0264

PISTON AND CRANKSHAFT

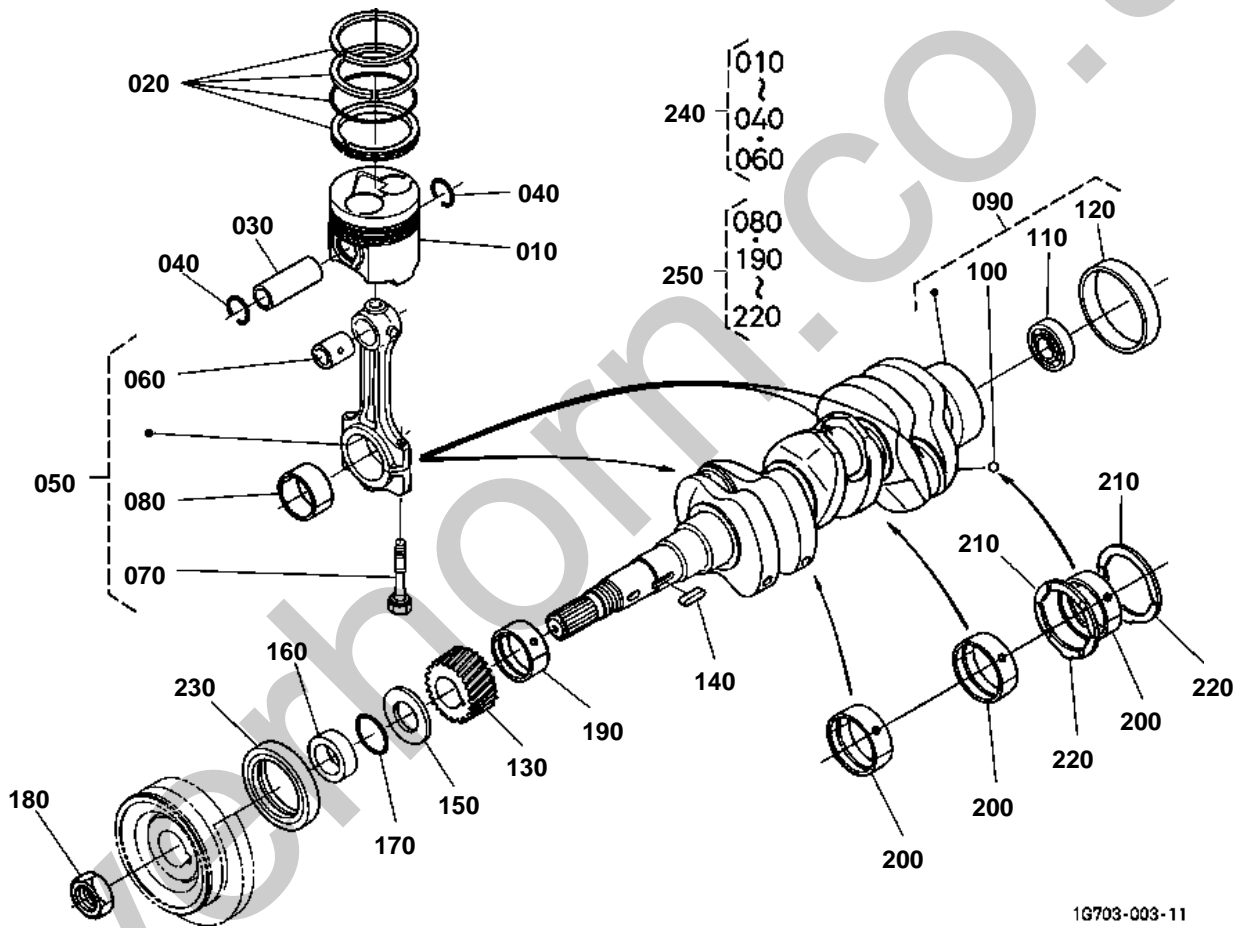

1G703-003-11



OLD PARTS

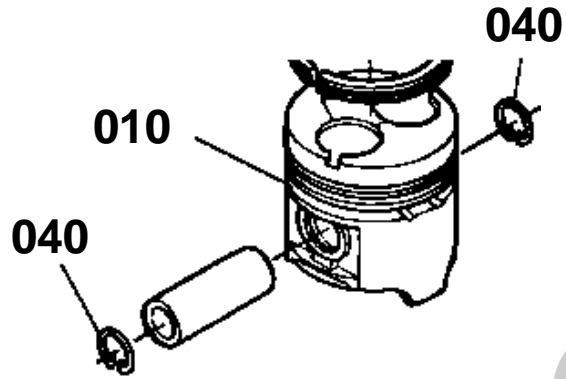

Silverhorn.CO.UK

1G726-805-10

**PISTON AND CRANKSHAFT**

NOTE : ORDER BY REF.No.010 and 040 NEW PART.

↔ Interchangeable; ≠ not interchangeable; ← new for old; → old for new

REF.No	Part No.	Description	Q'ty	S.No.	I/C	REMARKS	Weight (kgf)	Weight (lb)
010	1A001-21110	PISTON	3	≤4N0605		STD SEE NOTE	0.48	1.056
010	1A001-21112	PISTON	3	≥4Q0001	1	STD	0.48	1.056
010	1A001-21900	PISTON	3	≤4N0605		+0.25mm/ NOT SALE SEE NOTE	0.48	1.056
010	1A001-21902	PISTON	3	≥4Q0001	1	+0.25mm	0.48	1.056
020	1A001-21050	ASSY PISTON RING	3			STD	0.05	0.11
020	1A001-21092	ASSY PISTON RING	3			+0.25mm	0.05	0.11
030	14901-21310	PIN PISTON	3				0.17	0.374
040	14109-21330	CIR CLIP INTERNAL	6	≤4N0605			0.001	0.0022
040	1G279-21330	CIR CLIP INTERNAL	6	≥4Q0001	1		0.001	0.0022
050	17311-22010	ASSY CONNECTING ROD	3				0.885	1.947
060	17331-21980	BUSH PISTON PIN	3				0.025	0.055
070	15521-22142	BOLT CONNECTING ROD	6				0.026	0.0572
080	17311-22310	METAL CRANKPIN	3			STD/SET	0.045	0.099
080	17311-22970	METAL CRANKPIN	3			-0.20mm/SET	0.05	0.11
080	17311-22980	METAL CRANKPIN	3			-0.40mm/SET	0.045	0.099
090	1A033-23012	COMP.CRANKSHAFT	1				13.42	29.524
100	07715-00401	BALL	3				0.001	0.0022
110	08121-06002	BEARING BALL	1				0.03	0.066
120	19202-23280	BUSH CRANKSHAFT	1				0.09	0.198
130	1A081-24110	GEAR CRANKSHAFT	1				0.415	0.913
140	05712-00728	KEY FEATHER	1				0.01	0.022
150	15471-23312	SLINGER OIL	1				0.008	0.0176
160	19202-23250	COLLAR CRANKSHAFT	1				0.065	0.143
170	04811-10300	O RING	1				0.001	0.0022
180	15221-23360	NUT CRANKSHAFT	1				0.11	0.242
190	1A091-23470	METAL CRANKSHAFT	1			STD	0.062	0.1364
190	1A091-23910	METAL CRANKSHAFT	1			-0.20mm	0.065	0.143
190	1A091-23920	METAL CRANKSHAFT	1			-0.40mm	0.065	0.143
200	1A091-23480	METAL CRANKSHAFT	3			STD/SET	0.05	0.11
200	1A091-23930	METAL CRANKSHAFT	3			-0.20mm/SET	0.06	0.132
200	1A091-23940	METAL CRANKSHAFT	3			-0.40mm/SET	0.065	0.143
210	1A091-23530	METAL SIDE	2			STD	0.009	0.0198
210	1A091-23950	METAL SIDE	2			+0.20mm	0.005	0.011
210	1A091-23960	METAL SIDE	2			+0.40mm	0.005	0.011
220	1A091-23540	METAL SIDE	2			STD	0.009	0.0198
220	1A091-23970	METAL SIDE	2			+0.20mm	0.005	0.011
220	1A091-23980	METAL SIDE	2			+0.40mm	0.005	0.011
230	19202-04140	SEAL OIL	1				0.015	0.033
240	1G703-21770	KIT PISTON	3	≤4N0605		STD	0	0
240	1G703-21772	KIT PISTON	3	≥4Q0001	1	STD	0.825	1.815
240	1G703-21780	KIT PISTON	3	≤4N0605		+0.25mm	0	0
240	1G703-21782	KIT PISTON	3	≥4Q0001	1	+0.25mm	0.725	1.595
250	1G842-23750	KIT METAL ENGINE	1			STD	0.62	1.364
250	1G842-23760	KIT METAL ENGINE	1			-0.20mm/+0.20mm	0.65	1.43
250	1G842-23770	KIT METAL ENGINE	1			-0.40mm/+0.40mm	0.65	1.43

FLYWHEEL

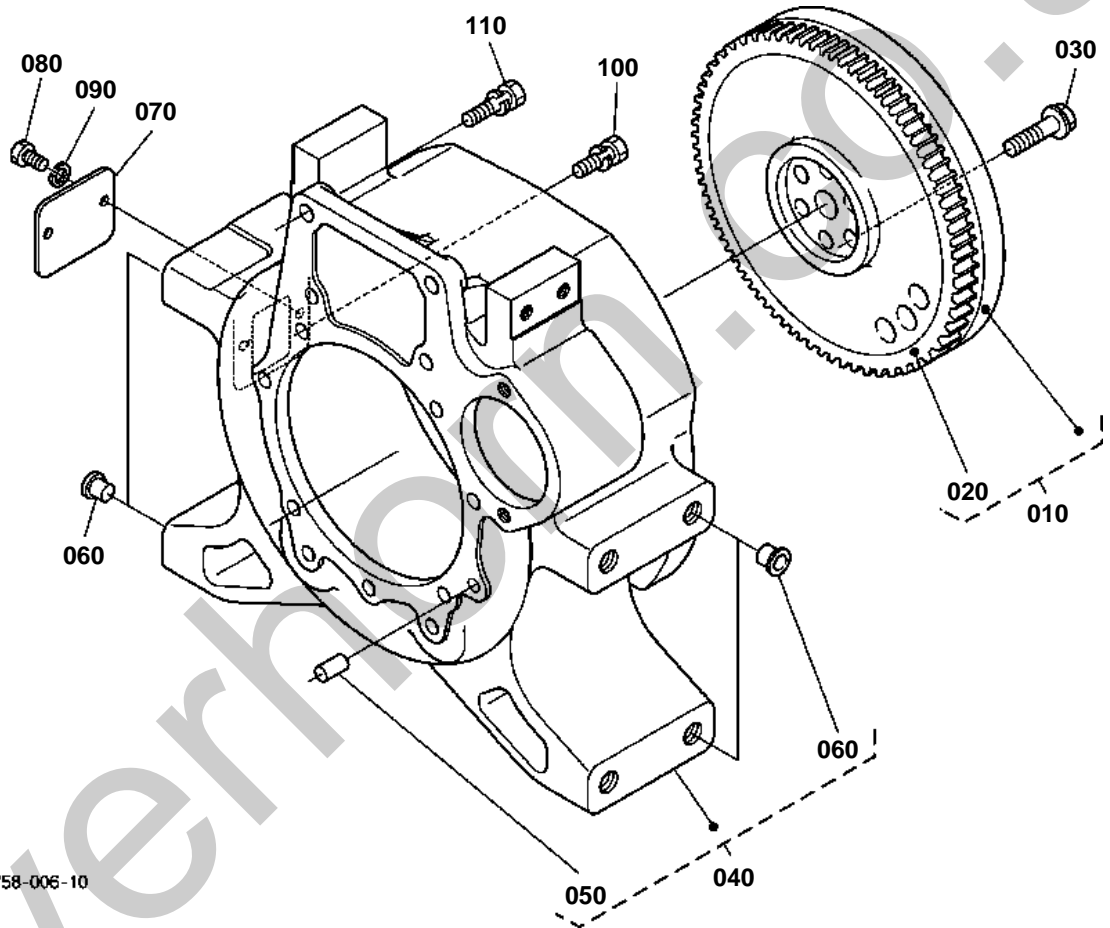

**FLYWHEEL**

↔ Interchangeable; ≠ not interchangeable; ← new for old; → old for new

REF.No	Part No.	Description	Q'ty	S.No.	I/C	REMARKS	Weight (kgf)	Weight (lb)
010	16417-25010	COMP.FLYWHEEL	1				15.5	34.1
020	15221-63820	GEAR RING	1				1.2	2.64
030	15321-25163	BOLT FLYWHEEL	6				0.05	0.11
040	TC220-20100	COMP.HOUSING F-W	1				37.5	82.5
050	05012-01018	PIN STRAIGHT	1				0.012	0.0264
060	33300-90910	PLUG	8				0.002	0.0044
070	TC220-14160	COVER	1				0.07	0.154
080	01153-50812	BOLT	2				0.008	0.0176
090	04512-60080	WASHER SPRING	2				0.002	0.0044
100	16427-91010	BOLT	11				0.004	0.0088
110	01133-51240	BOLT	2				0.05	0.11

FUEL CAMSHAFT

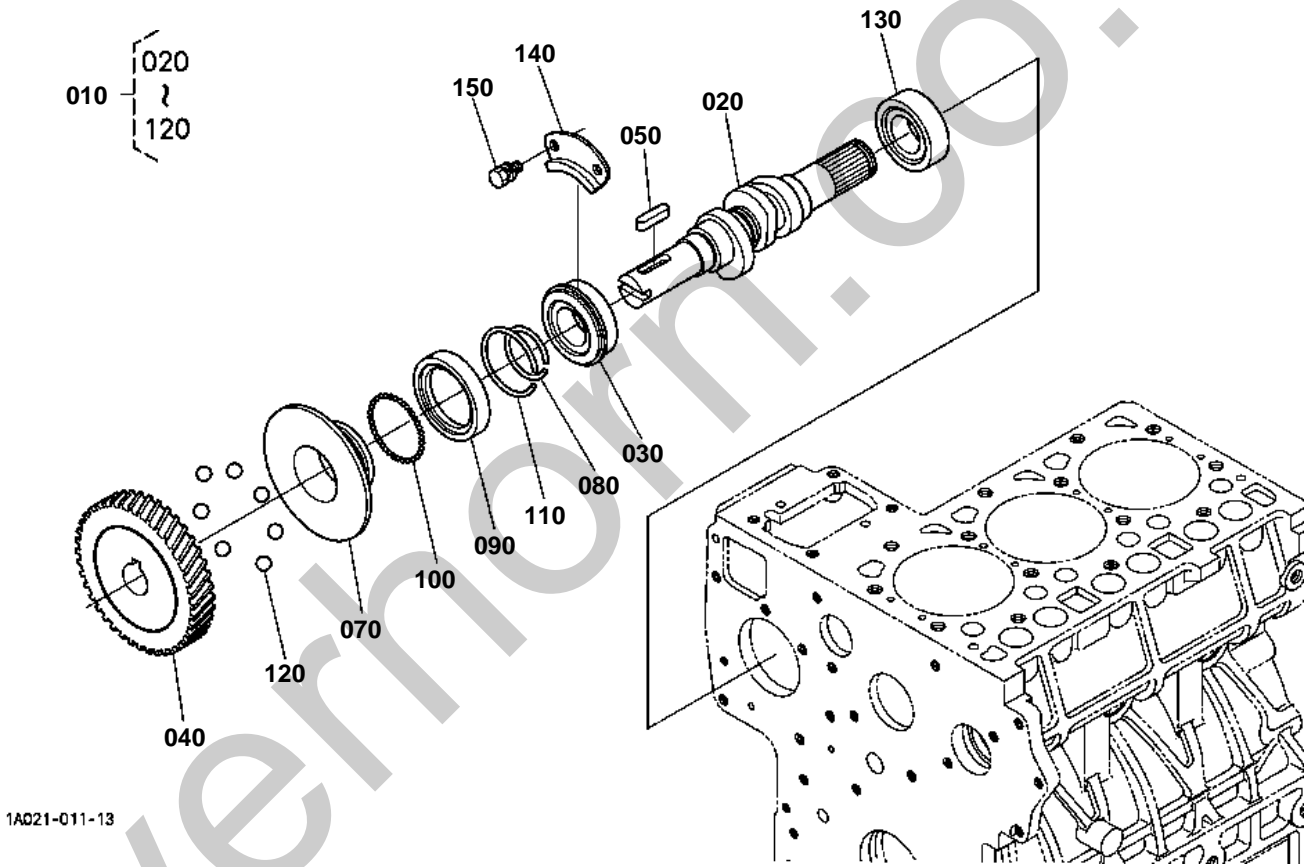

OLD PARTS

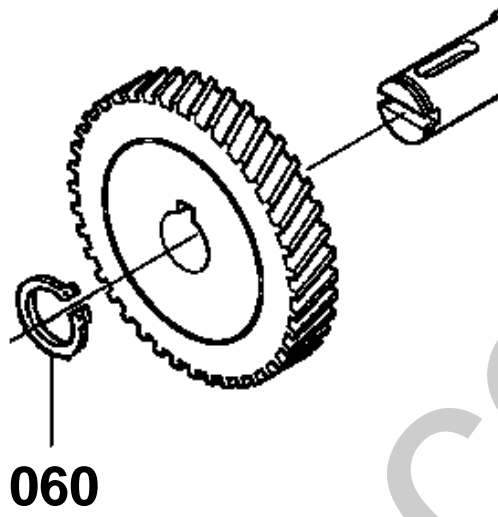

Silverhorn.CO.UK

1A041-801-11



## FUEL CAMSHAFT

↔ Interchangeable; ≠ not interchangeable; ← new for old; → old for new

REF.No	Part No.	Description	Q'ty	S.No.	I/C	REMARKS	Weight (kgf)	Weight (lb)
010	16427-16020	ASSY CAMSHAFT FUEL	1				2.5	5.5
020	16427-16173	CAMSHAFT FUEL	1				0.99	2.178
030	08153-06205	BEARING BALL	1				0.13	0.286
040	16415-51150	GEAR INJECTION PUMP	1				1.075	2.365
050	05712-00525	KEY FEATHER	1				0.005	0.011
060	04612-00240	CIR CLIP EXTERNAL	1	<=4E1036			0.002	0.0044
070	15611-55450	SLEEVE GOVERNOR	1				0.117	0.2574
080	15221-55470	CIR-CLIP GOV. SLEEVE	1				0.003	0.0066
090	15611-55690	CASE GOVERNOR BALL	1				0.03	0.066
100	07715-03205	BALL	39				0.001	0.0022
110	15221-55740	CIR-CLIP	1				0.002	0.0044
120	07715-00403	BALL	7				0.03	0.066
130	1A021-97300	BEARING BALL	1				0.125	0.275
140	15221-16320	STOPPER FUEL C/SHAFT	1				0.02	0.044
150	01123-60814	BOLT	2				0.01	0.022

ENGINE STOP LEVER

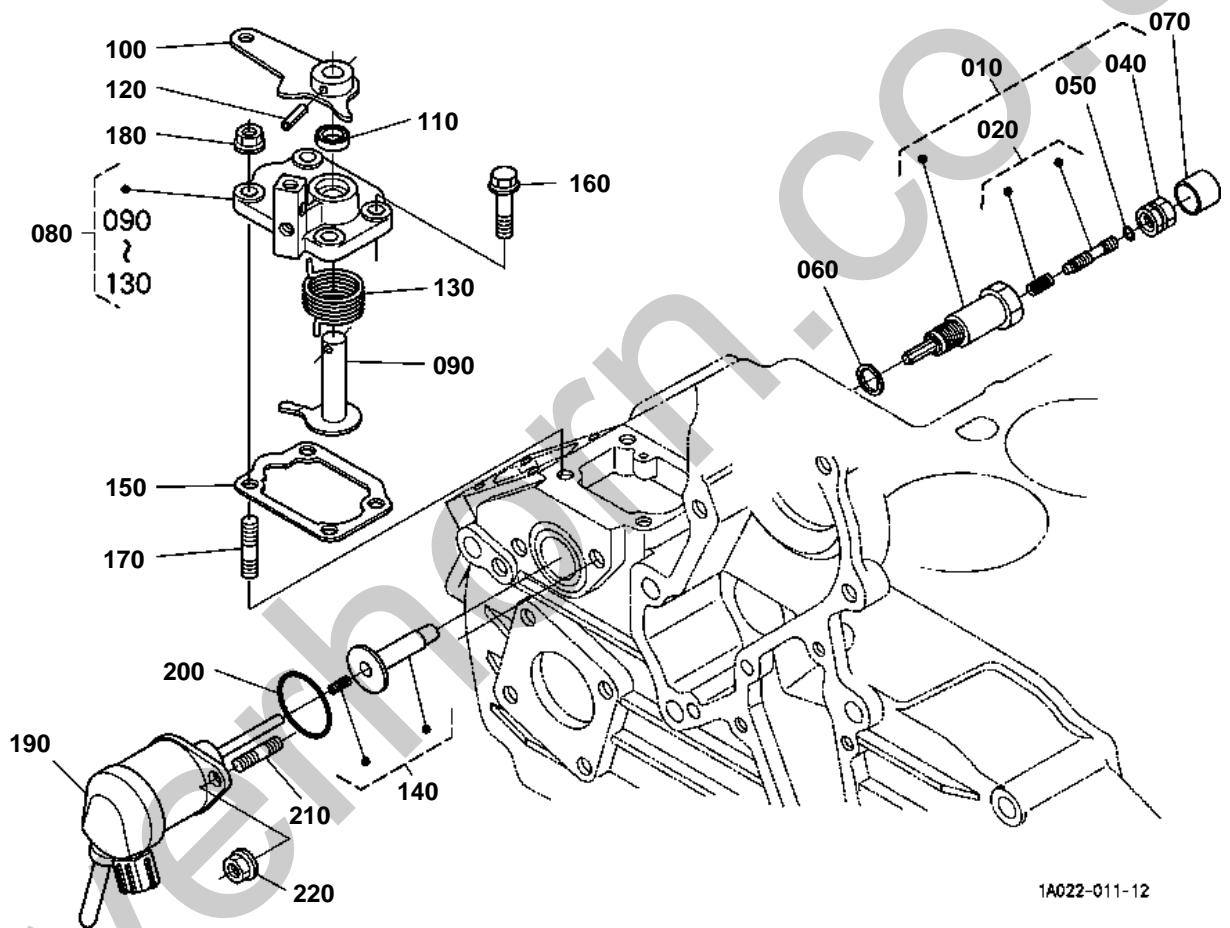

1A022-011-12





# ENGINE STOP LEVER

↔ Interchangeable; ≠ not interchangeable; ← new for old; → old for new

REF.No	Part No.	Description	Q'ty	S.No.	I/C	REMARKS	Weight (kgf)	Weight (lb)
010	1A021-54160	APPARATUS IDLING	1				0.103	0.2266
020	1G911-54100	ASSY BOLT ADJUSTMENT	1				0.008	0.0176
030	99999-99999	BLANK	0				0	0
040	1G911-92010	NUT SPRING	1				0.015	0.033
050	04814-00060	O RING	1				0.001	0.0022
060	04724-00140	GASKET	1				0.002	0.0044
070	1G911-54270	CAP	1				0.002	0.0044
080	1A021-57700	ASSY LEVER ENG.STOP	1	<=5S0827			0.184	0.4048
080	1A021-57703	ASSY LEVER ENG.STOP	1	>=5U0001	-		0.184	0.4048
090	1A021-57710	COMP.LEVER STOP	1				0.038	0.0836
100	1A021-57720	LEVER ENGINE STOP	1				0.055	0.121
110	15471-57980	SEAL OIL	1	<=5S0827			0.001	0.0022
110	16691-57980	SEAL OIL	1	>=5U0001	-		0.001	0.0022
120	05411-00420	PIN SPRING	1				0.001	0.0022
130	1A021-57920	SPRING RETURN	1				0.01	0.022
140	1A021-56602	COMP.GUIDE SOLENOID	1				0.007	0.0154
150	1A021-57210	GASKET PLATE	1				0.001	0.0022
160	01023-50620	BOLT	2				0.006	0.0132
170	15221-88210	STUD	2				0.005	0.011
180	02751-50060	NUT FLANGE	2				0.005	0.011
190	1A021-60013	ASSY SOLENOID	1				0.29	0.638
200	04814-06310	O RING	1				0.002	0.0044
210	15221-88210	STUD	2				0.005	0.011
220	02761-50060	NUT FLANGE	2				0.003	0.0066

INJECTION PUMP

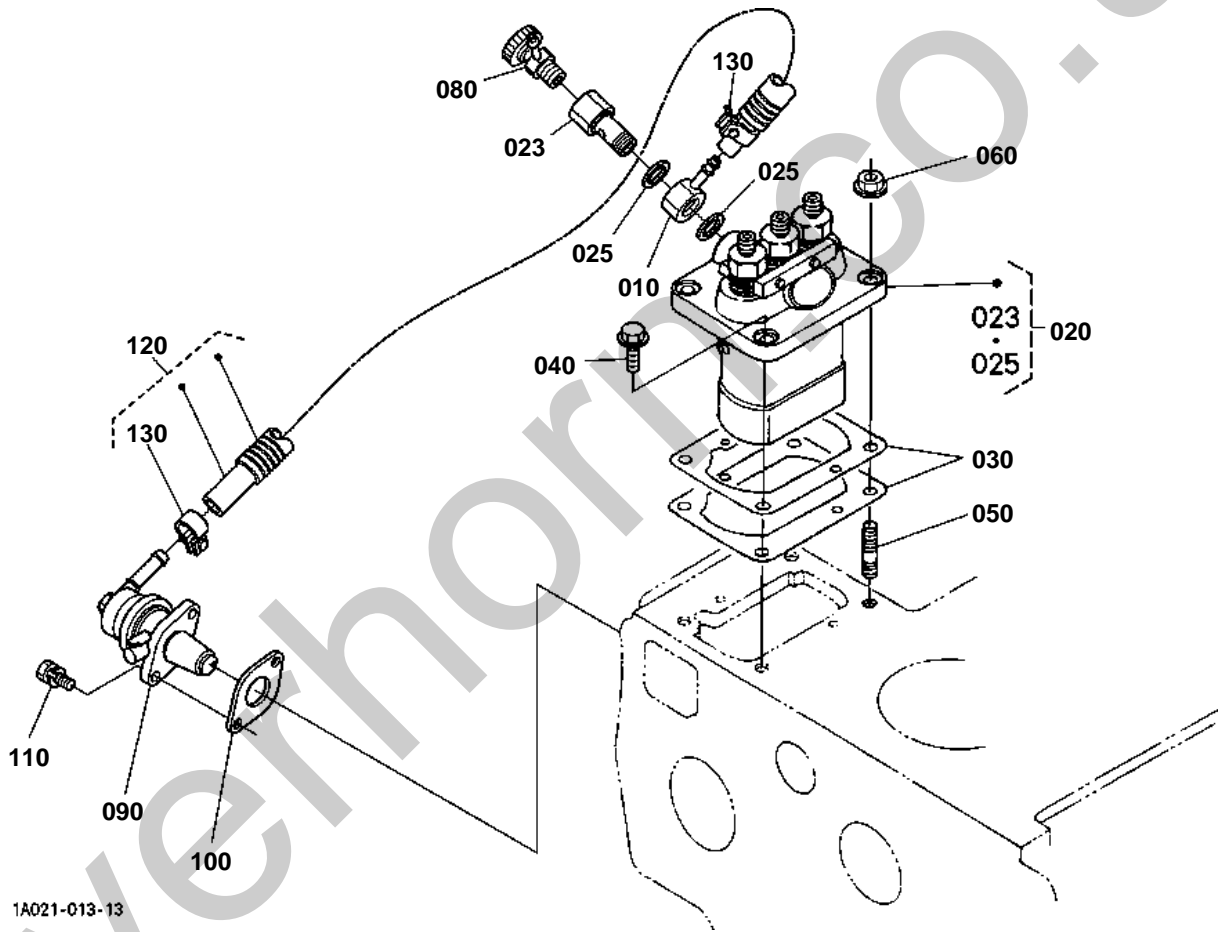

1A021-013-13

# OLD PARTS

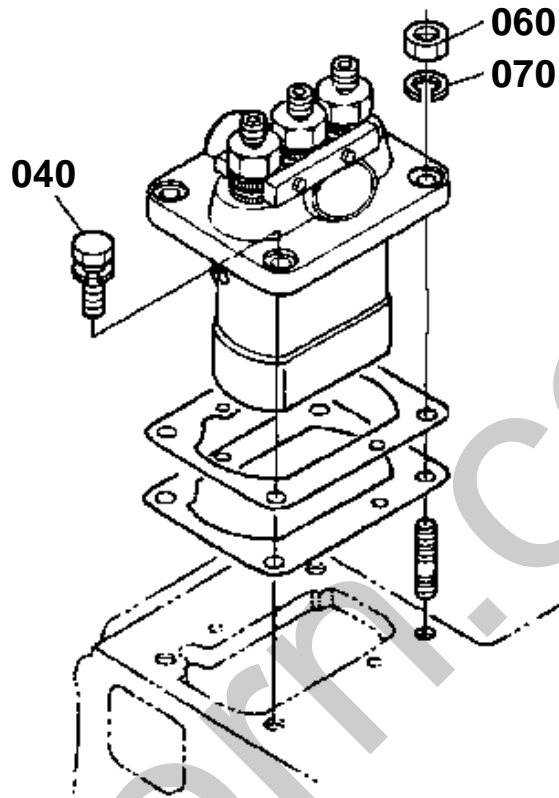

1G758-801-10

**INJECTION PUMP**

↔ Interchangeable; ≠ not interchangeable; ← new for old; → old for new

REF.No	Part No.	Description	Q'ty	S.No.	I/C	REMARKS	Weight (kgf)	Weight (lb)
010	14111-42410	JOINT EYE	1				0.025	0.055
020	1G702-51010	ASSY PUMP INJECTION	1				2.2	4.84
023	15521-51320	SCREW HOLLOW	1				0.035	0.077
025	15221-96650	GASKET	2				0.001	0.0022
030	16414-52090	SHIM INJECTION PUMP	1			0.20mm	0.001	0.0022
030	16414-52110	SHIM INJECTION PUMP	1			0.25mm	0.001	0.0022
030	16414-52120	SHIM INJECTION PUMP	1			0.30mm	0.005	0.011
040	01123-50822	BOLT	2	<=4W1690			0.012	0.0264
040	01754-50820	BOLT FLANGE	2	>=4Y0001	-		0.015	0.033
050	15221-91530	STUD	2				0.011	0.0242
060	02156-50080	NUT	2	<=4W1690			0.004	0.0088
060	02751-50080	NUT FLANGE	2	>=4Y0001	-		0.006	0.0132
070	04512-60080	WASHER SPRING	2	<=4W1690			0.002	0.0044
080	14311-60504	ASSY COCK JET START	1				0.034	0.0748
090	17121-52030	ASSY PUMP FUEL	1				0.13	0.286
100	1A021-52140	GASKET FUEL PUMP	1				0.001	0.0022
100	1G751-52140	GASKET FUEL PUMP	1			«	0.001	0.0022
110	01023-50616	BOLT	2				0.005	0.011
120	T1060-42600	ASSY TUBE FUEL	1				0.043	0.0946
130	14301-42750	CLIP PIPE	2				0.005	0.011

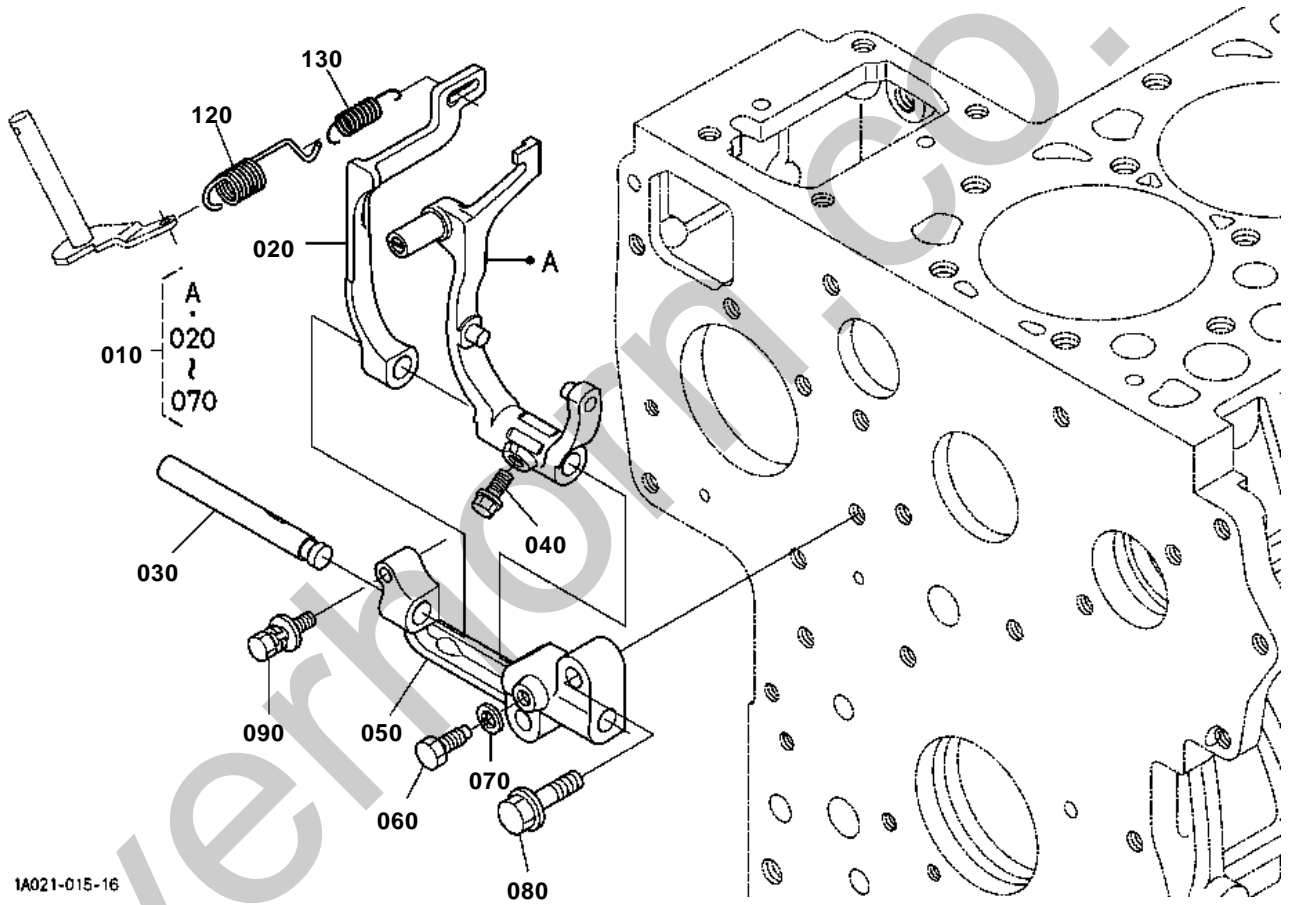

1A021-015-16



GOVERNOR

↔ Interchangeable; ≠ not interchangeable; ← new for old; → old for new

REF.No	Part No.	Description	Q'ty	S.No.	I/C	REMARKS	Weight (kgf)	Weight (lb)
010	1G703-56050	ASSY LEVER FORK	1				0.365	0.803
020	1A021-56133	LEVER FORK	1				0.035	0.077
030	1G911-56150	SHAFT FORK LEVER	1				0.05	0.11
040	01754-50618	BOLT FLANGE	1				0.01	0.022
050	15221-56230	HOLDER FORK LEVER	1				0.1	0.22
060	15221-66410	BOLT	1				0.005	0.011
070	04512-60060	WASHER SPRING	1				0.001	0.0022
080	01754-50830	BOLT FLANGE	2				0.05	0.11
090	01025-50630	BOLT	1				0.009	0.0198
100	99999-99999	BLANK	0				0	0
110	99999-99999	BLANK	0				0	0
120	1A023-56410	SPRING GOVERNOR	1	<=4U0617			0	0
120	1A023-56412	SPRING GOVERNOR	1	>=4W0001	↔		0	0
120	1A023-56413	SPRING GOVERNOR	1	>=5G0001	↔		0.005	0.011
130	1A021-56420	SPRING GOVERNOR	1	<=5E0875			0.002	0.0044
130	1A021-56422	SPRING GOVERNOR	1	>=5G0001	↔		0.002	0.0044

SPEED CONTROL PLATE

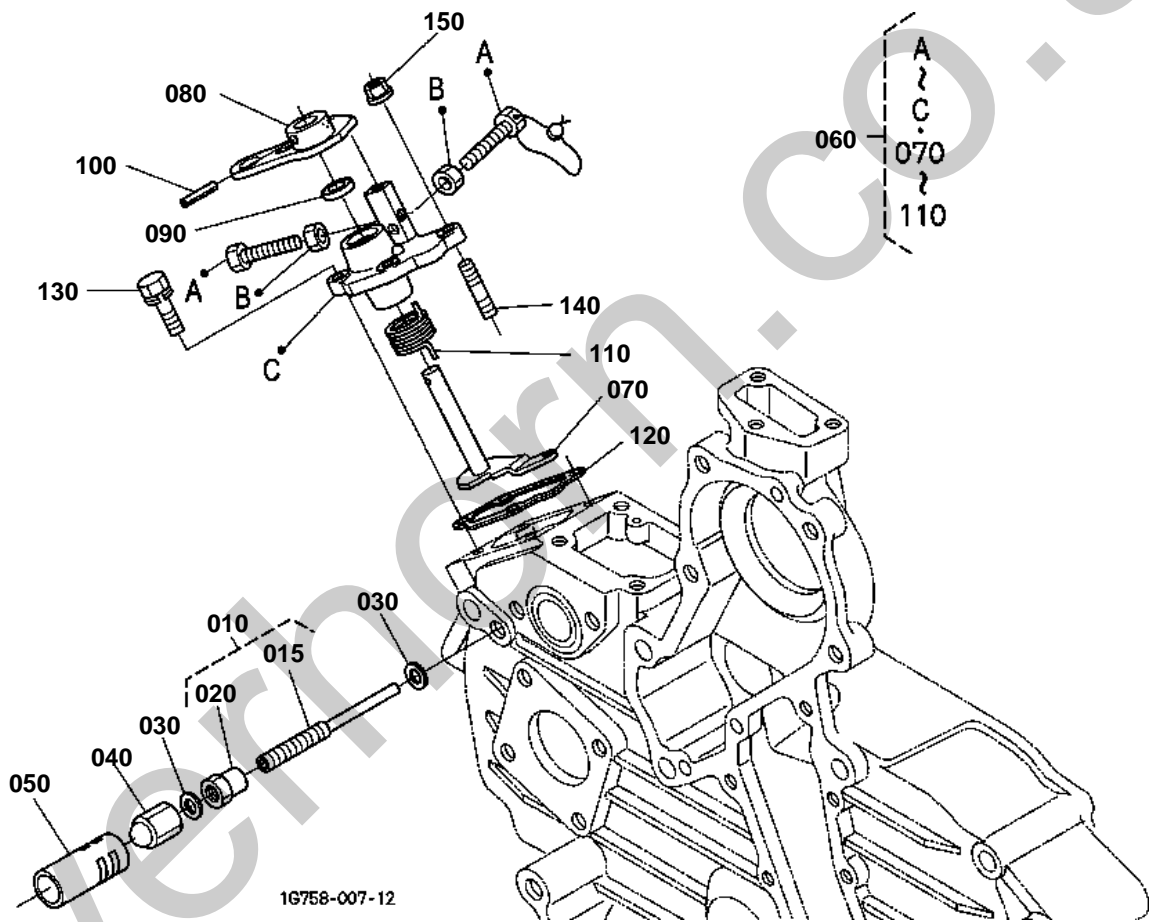



## SPEED CONTROL PLATE

↔ Interchangeable; ≠ not interchangeable; ← new for old; → old for new

REF.No	Part No.	Description	Q'ty	S.No.	I/C	REMARKS	Weight (kgf)	Weight (lb)
010	1A021-54350	ASSY BOLT ADJUSTMENT	1				0.015	0.033
015	1A021-54120	BOLT ADJUSTING	1				0.009	0.0198
020	15601-92012	NUT	1				0.006	0.0132
030	15601-96650	GASKET	2				0.001	0.0022
040	15841-14620	NUT	1				0.01	0.022
050	99999-99999	PIPE LOCK	1				0	0
060	1G790-57000	ASSY PLATE CONTROL	1	<=5S0827			0.046	0.1012
060	1G790-57004	ASSY PLATE CONTROL	1	>=5U0001	-		0.046	0.1012
070	1A021-56020	COMP.LEVER GOVERNOR	1				0.046	0.1012
080	1G790-57150	LEVER SPEED CONTROL	1				0.21	0.462
090	15471-57980	SEAL OIL	1	<=5S0827			0.001	0.0022
090	16691-57980	SEAL OIL	1	>=5U0001	-		0.001	0.0022
100	05411-00420	PIN SPRING	1				0.001	0.0022
110	1A021-57920	SPRING RETURN	1				0.01	0.022
120	1A021-57210	GASKET PLATE	1				0.001	0.0022
130	01023-50620	BOLT	2				0.006	0.0132
140	15221-88210	STUD	2				0.005	0.011
150	02751-50060	NUT FLANGE	2				0.005	0.011



NOZZLE HOLDER AND GLOW PLUG

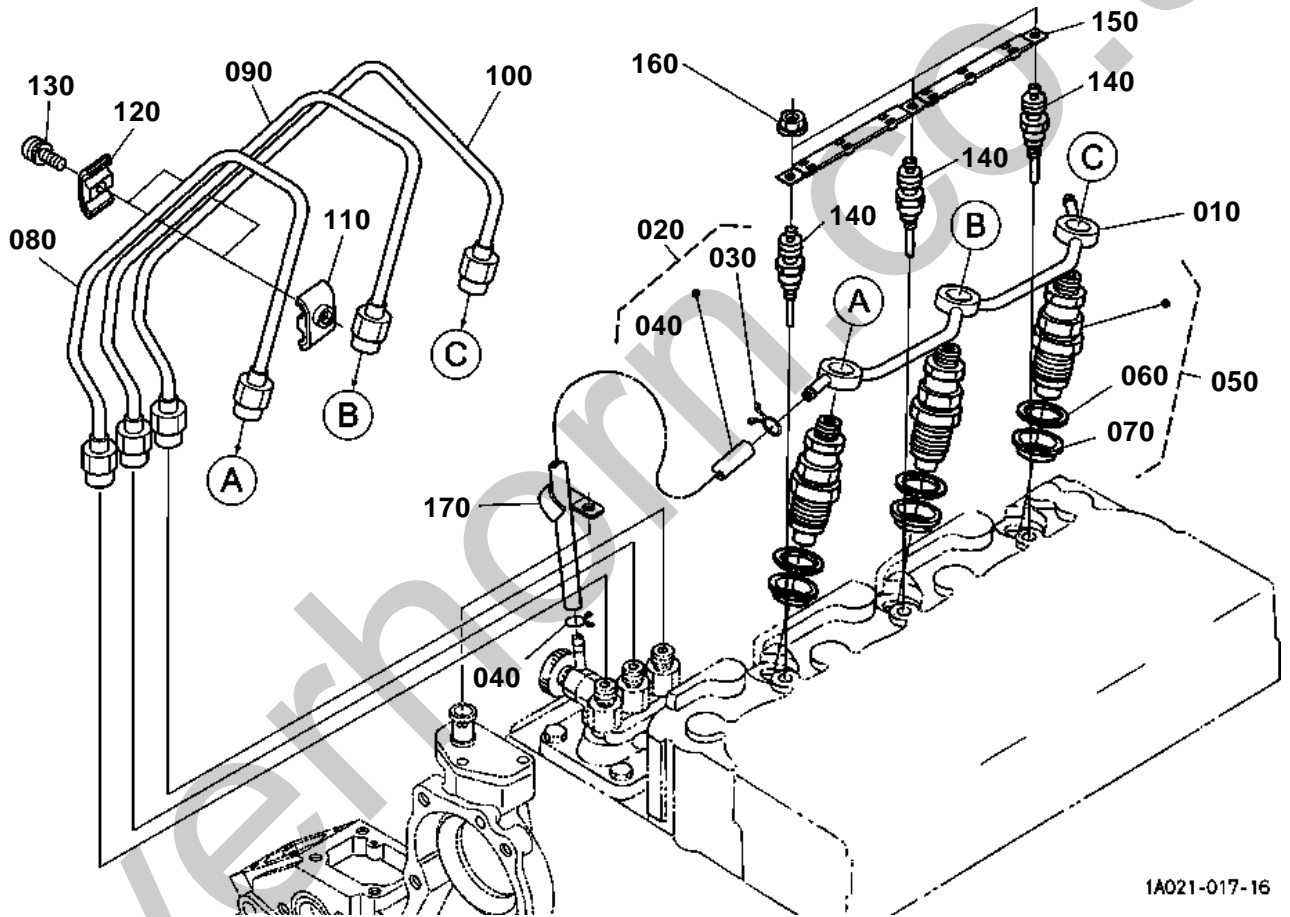

1A021-017-16

## OLD PARTS

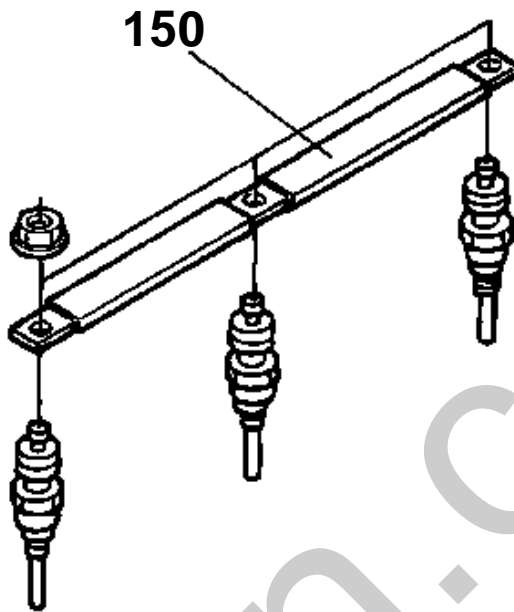

Silverhorn.CO.UK

1G755-800-10



## NOZZLE HOLDER AND GLOW PLUG

↔ Interchangeable; ≠ not interchangeable; ← new for old; → old for new

REF.No	Part No.	Description	Q'ty	S.No.	I/C	REMARKS	Weight (kgf)	Weight (lb)
010	16467-42502	ASSY PIPE OVER FLOW	1				0.045	0.099
020	17331-42500	ASSY PIPE OVER FLOW	1				0.02	0.044
030	14971-42750	CLIP PIPE	1				0.001	0.0022
040	10244-42320	CLIP PIPE	1				0.001	0.0022
050	16082-53900	KIT HOLDER NOZZLE	3				0.145	0.319
060	15841-53622	GASKET	3				0.002	0.0044
070	19077-53650	SEAL HEAT	3				0.005	0.011
080	19077-53714	PIPE INJECTION	1				0.14	0.308
090	19077-53723	PIPE INJECTION	1				0.14	0.308
100	19077-53733	PIPE INJECTION	1				0.12	0.264
110	15841-53850	CLAMP PIPE	2				0.01	0.022
120	15841-53860	CLAMP PIPE	2				0.009	0.0198
130	03024-50520	SCREW WITH WASHER	2				0.004	0.0088
140	19077-65510	GLOW PLUG	3				0.03	0.066
150	16415-65560	CORD GLOW PLUG	1				0.015	0.033
150	1G742-65560	CORD GLOW PLUG	1		«		0	0
160	02761-50040	NUT FLANGE	3				0.002	0.0044
170	15241-67580	CLAMP CORD	1				0.004	0.0088

NOZZLE HOLDER [COMPONENT PARTS]

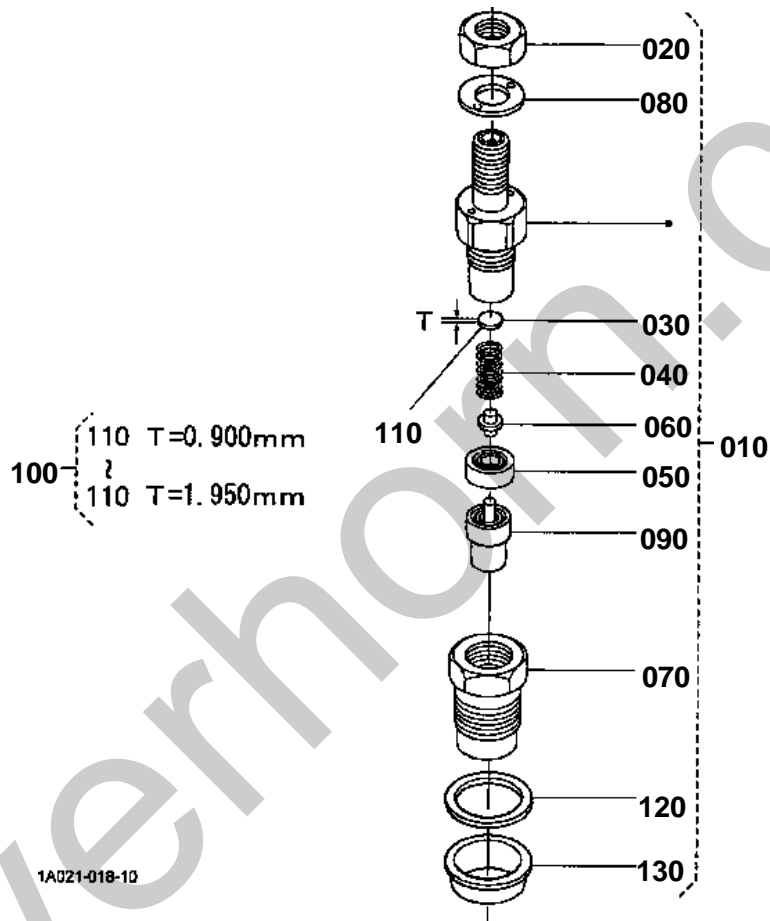

**NOZZLE HOLDER [COMPONENT PARTS]**

↔ Interchangeable; ≠ not interchangeable; ← new for old; → old for new

REF.No	Part No.	Description	Q'ty	S.No.	I/C	REMARKS	Weight (kgf)	Weight (lb)
010	16082-53900	KIT HOLDER NOZZLE	3				0.145	0.319
020	15841-92030	NUT	3				0.005	0.011
030	15841-53230	WASHER ADJUSTING	3				0.001	0.0022
040	15841-53170	SPRING NOZZLE	3				0.004	0.0088
050	15841-53350	PIECE DISTANCE	3				0.004	0.0088
060	15841-53160	PUSH ROD	3				0.001	0.0022
070	16475-53280	NUT NOZZLE	3				0.03	0.066
080	15841-94040	WASHER	3				0.001	0.0022
090	16082-53610	PIECE NOZZLE	3				0.023	0.0506
100	15841-98100	ASSY WASHER ADJUST	3			OPTION	0.043	0.0946
110	15841-53230	WASHER ADJUSTING	3			0.900mm	0.001	0.0022
110	15841-98510	WASHER ADJUSTING	3			0.925mm	0.001	0.0022
110	15841-98520	WASHER ADJUSTING	3			0.950mm	0.001	0.0022
110	15841-98530	WASHER ADJUSTING	3			0.975mm	0.001	0.0022
110	15841-98540	WASHER ADJUSTING	3			1.000mm	0.001	0.0022
110	15841-98550	WASHER ADJUSTING	3			1.025mm	0.001	0.0022
110	15841-98560	WASHER ADJUSTING	3			1.050mm	0.001	0.0022
110	15841-98570	WASHER ADJUSTING	3			1.075mm	0.001	0.0022
110	15841-98580	WASHER ADJUSTING	3			1.100mm	0.001	0.0022
110	15841-98590	WASHER ADJUSTING	3			1.125mm	0.001	0.0022
110	15841-98600	WASHER ADJUSTING	3			1.150mm	0.001	0.0022
110	15841-98610	WASHER ADJUSTING	3			1.175mm	0.001	0.0022
110	15841-98620	WASHER ADJUSTING	3			1.200mm	0.001	0.0022
110	15841-98630	WASHER ADJUSTING	3			1.225mm	0.001	0.0022
110	15841-98640	WASHER ADJUSTING	3			1.250mm	0.001	0.0022
110	15841-98650	WASHER ADJUSTING	3			1.275mm	0.001	0.0022
110	15841-98660	WASHER ADJUSTING	3			1.300mm	0.001	0.0022
110	15841-98670	WASHER ADJUSTING	3			1.325mm	0.001	0.0022
110	15841-98680	WASHER ADJUSTING	3			1.350mm	0.001	0.0022
110	15841-98690	WASHER ADJUSTING	3			1.375mm	0.001	0.0022
110	15841-98700	WASHER ADJUSTING	3			1.400mm	0.001	0.0022
110	15841-98710	WASHER ADJUSTING	3			1.425mm	0.001	0.0022
110	15841-98720	WASHER ADJUSTING	3			1.450mm	0.001	0.0022
110	15841-98730	WASHER ADJUSTING	3			1.475mm	0.001	0.0022
110	15841-98740	WASHER ADJUSTING	3			1.500mm	0.001	0.0022
110	15841-98750	WASHER ADJUSTING	3			1.525mm	0.001	0.0022
110	15841-98760	WASHER ADJUSTING	3			1.550mm	0.001	0.0022
110	15841-98770	WASHER ADJUSTING	3			1.575mm	0.001	0.0022
110	15841-98780	WASHER ADJUSTING	3			1.600mm	0.002	0.0044
110	15841-98790	WASHER ADJUSTING	3			1.625mm	0.001	0.0022
110	15841-98800	WASHER ADJUSTING	3			1.650mm	0.001	0.0022
110	15841-98810	WASHER ADJUSTING	3			1.675mm	0.004	0.0088
110	15841-98820	WASHER ADJUSTING	3			1.700mm	0.001	0.0022
110	15841-98830	WASHER ADJUSTING	3			1.725mm	0.001	0.0022
110	15841-98840	WASHER ADJUSTING	3			1.750mm	0.001	0.0022
110	15841-98850	WASHER ADJUSTING	3			1.775mm	0.001	0.0022
110	15841-98860	WASHER ADJUSTING	3			1.800mm	0.001	0.0022
110	15841-98870	WASHER ADJUSTING	3			1.825mm	0.001	0.0022
110	15841-98880	WASHER ADJUSTING	3			1.850mm	0.001	0.0022
110	15841-98890	WASHER ADJUSTING	3			1.875mm	0.001	0.0022
110	15841-98900	WASHER ADJUSTING	3			1.900mm	0.001	0.0022



## NOZZLE HOLDER [COMPONENT PARTS]

↔ Interchangeable; ≠ not interchangeable; ← new for old; → old for new

REF.No	Part No.	Description	Q'ty	S.No.	I/C	REMARKS	Weight (kgf)	Weight (lb)
110	15841-98910	WASHER ADJUSTING	3			1.925mm	0.001	0.0022
110	15841-98920	WASHER ADJUSTING	3			1.950mm	0.001	0.0022
120	15841-53622	GASKET	3				0.002	0.0044
130	19077-53650	SEAL HEAT	3				0.005	0.011

WATER FLANGE AND THERMOSTAT

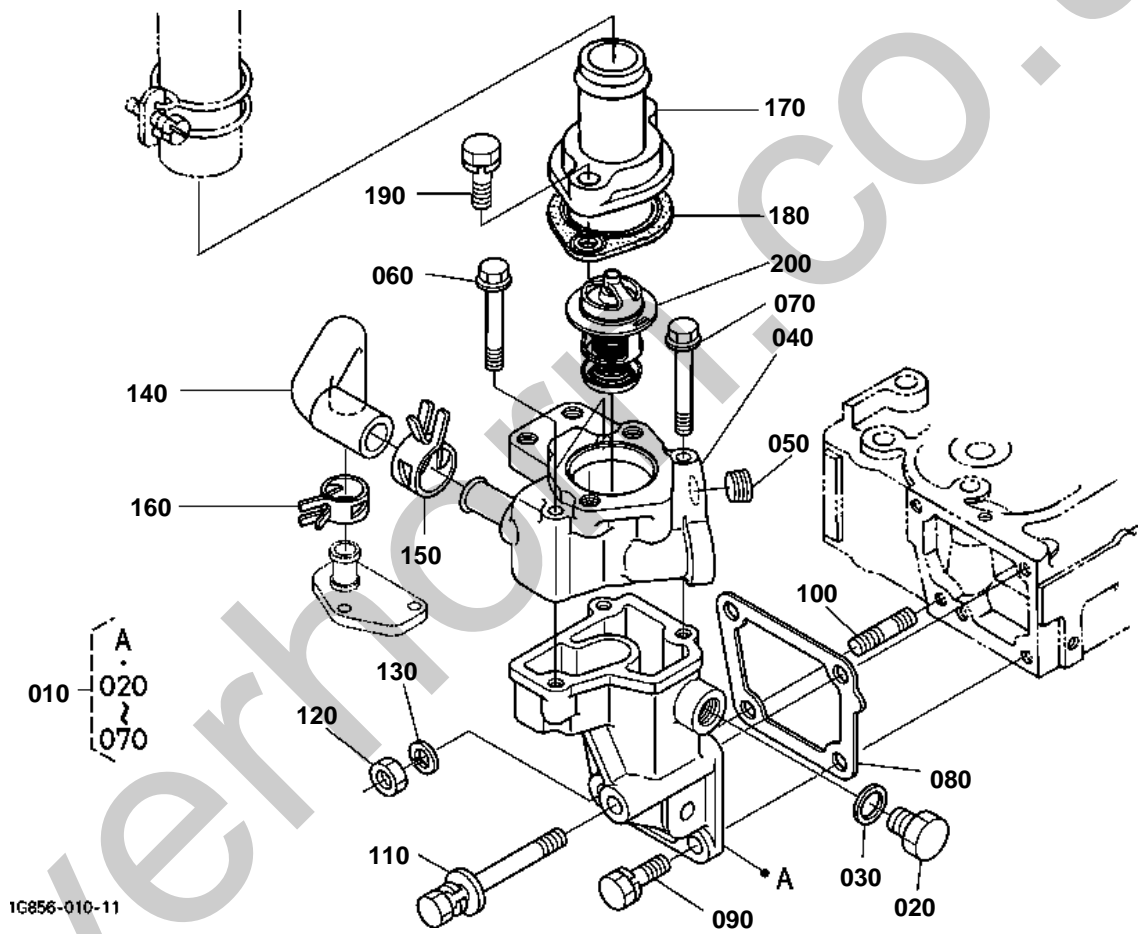



# WATER FLANGE AND THERMOSTAT

↔ Interchangeable; ≠ not interchangeable; ← new for old; → old for new

REF.No	Part No.	Description	Q'ty	S.No.	I/C	REMARKS	Weight (kgf)	Weight (lb)
010	1A033-72704	COMP.FLANGE WATER	1				0.755	1.661
020	15109-33630	PLUG DRAIN	1				0.025	0.055
030	15109-33660	GASKET	1				0.001	0.0022
040	1A021-72914	FLANGE WATER	1				0.375	0.825
050	1A021-96020	PLUG	1				0.015	0.033
060	01754-50660	BOLT FLANGE	2				0.02	0.044
070	01754-50665	BOLT FLANGE	1				0.01	0.022
080	1A021-72920	GASKET WATER FLANGE	1				0.002	0.0044
090	01123-50820	BOLT	2				0.011	0.0242
100	15221-91530	STUD	1				0.011	0.0242
110	1A021-91020	BOLT	1				0.032	0.0704
120	02156-50080	NUT	1				0.004	0.0088
130	04512-60080	WASHER SPRING	1				0.002	0.0044
140	1A021-73340	PIPE WATER RETURN	1				0.032	0.0704
150	09318-88200	CLAMP HOSE	1				0.004	0.0088
160	09318-88180	CLAMP HOSE	1				0.01	0.022
170	15321-73260	COVER THERMOSTAT	1				0.107	0.2354
180	16221-73270	GASKET THERMOSTAT	1				0.01	0.022
190	01123-50835	BOLT	2				0.02	0.044
200	1A021-73012	ASSY THERMOSTAT	1				0.079	0.1738



WATER PUMP

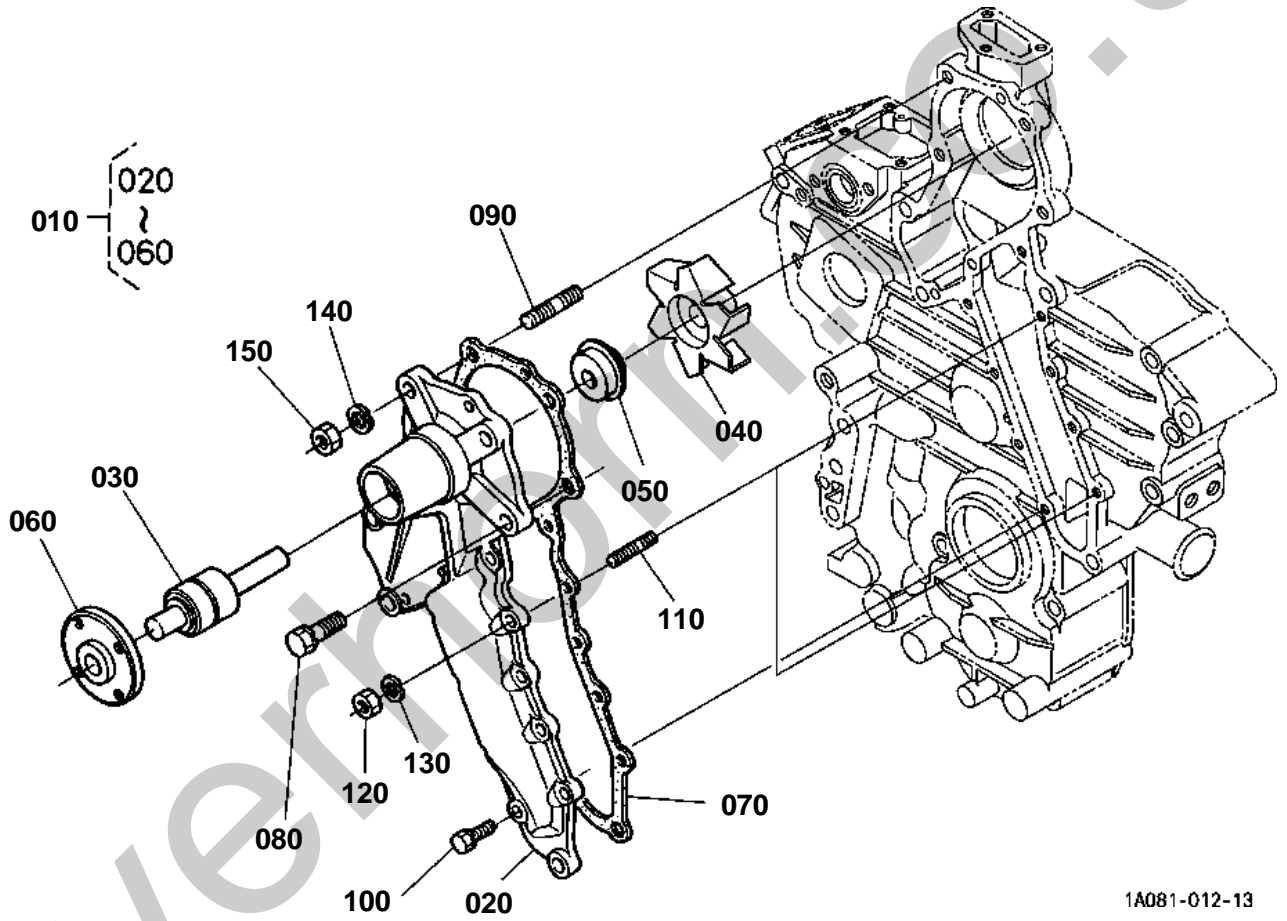

1A081-012-13



# WATER PUMP

↔ Interchangeable; ≠ not interchangeable; ← new for old; → old for new

REF.No	Part No.	Description	Q'ty	S.No.	I/C	REMARKS	Weight (kgf)	Weight (lb)
010	1A021-73030	ASSY PUMP WATER	1				1	2.2
020	17331-73410	BODY WATER PUMP	1				0.51	1.122
030	15521-73550	BEARING	1				0.235	0.517
040	1A021-73510	IMPELLER WATER PUMP	1				0.065	0.143
050	16661-73050	ASSY SEAL MECHANICAL	1				0.025	0.055
060	1A021-73520	FLANGE W/PUMP SHAFT	1				0.185	0.407
070	1A021-73430	GASKET WATER PUMP	1				0.007	0.0154
080	01123-50828	BOLT	3				0.014	0.0308
090	01518-50822	STUD	1				0.012	0.0264
100	01023-50618	BOLT	8				0.006	0.0132
110	15221-88210	STUD	1				0.005	0.011
120	02056-50060	NUT	1				0.002	0.0044
130	04512-60060	WASHER SPRING	1				0.001	0.0022
140	04512-60080	WASHER SPRING	1				0.002	0.0044
150	02156-50080	NUT	1				0.004	0.0088

VALVE AND ROCKER ARM

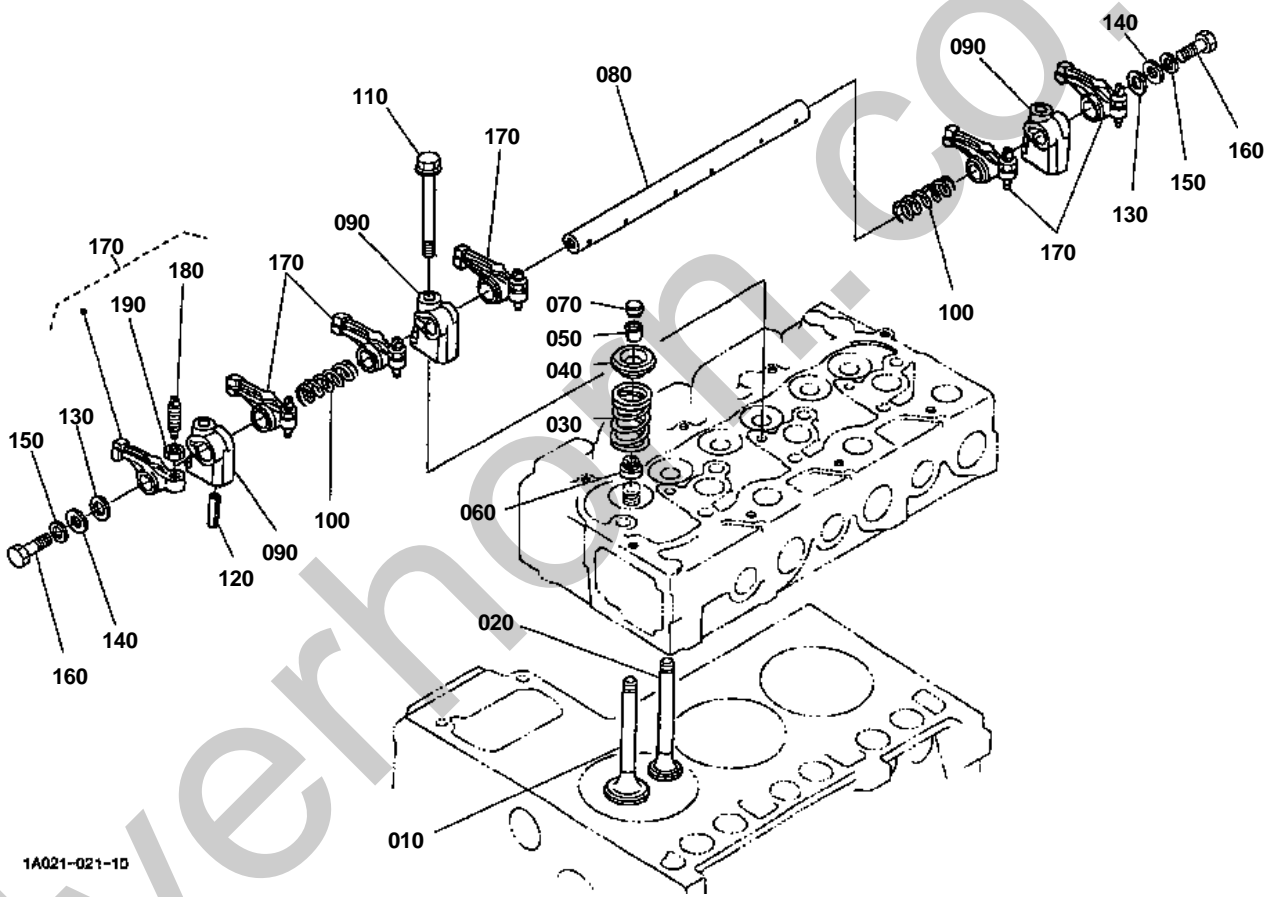

1A021-021-1D



# VALVE AND ROCKER ARM

↔ Interchangeable; ≠ not interchangeable; ← new for old; → old for new

REF.No	Part No.	Description	Q'ty	S.No.	I/C	REMARKS	Weight (kgf)	Weight (lb)
010	16484-13110	VALVE INLET	3				0.06	0.132
020	16484-13120	VALVE EXHAUST	3				0.13	0.286
030	15221-13240	SPRING VALVE	6				0.036	0.0792
040	15221-13330	RETAINER VALVE SP.	6				0.03	0.066
050	15221-13980	COLLET VALVE SPRING	6			SET	0.002	0.0044
060	15221-13153	SEAL VALVE STEM	6				0.001	0.0022
070	15221-13280	CAP VALVE	6				0.006	0.0132
080	1A021-14260	SHAFT ROCKER ARM	1				0.225	0.495
090	15221-14350	BRACKET ROCKER ARM	3	<=5A0175			0.044	0.0968
090	15221-14353	BRACKET ROCKER ARM	3	>=5C0001			0.044	0.0968
100	15221-14310	SPRING ROCKER ARM	2				0.005	0.011
110	01754-50855	BOLT FLANGE	3				0.02	0.044
120	05411-00528	PIN SPRING	1				0.003	0.0066
130	15221-14430	WASHER R-ARM.SHAFT	2				0.002	0.0044
140	04013-60080	WASHER PLAIN	2				0.002	0.0044
150	04512-60080	WASHER SPRING	2				0.002	0.0044
160	01153-50812	BOLT	2				0.008	0.0176
170	15621-14030	ASSY ROCKER ARM	6				0.1	0.22
180	15521-14230	SCREW ADJUSTING	6				0.009	0.0198
190	15021-14240	NUT	6				0.003	0.0066

INLET MANIFOLD

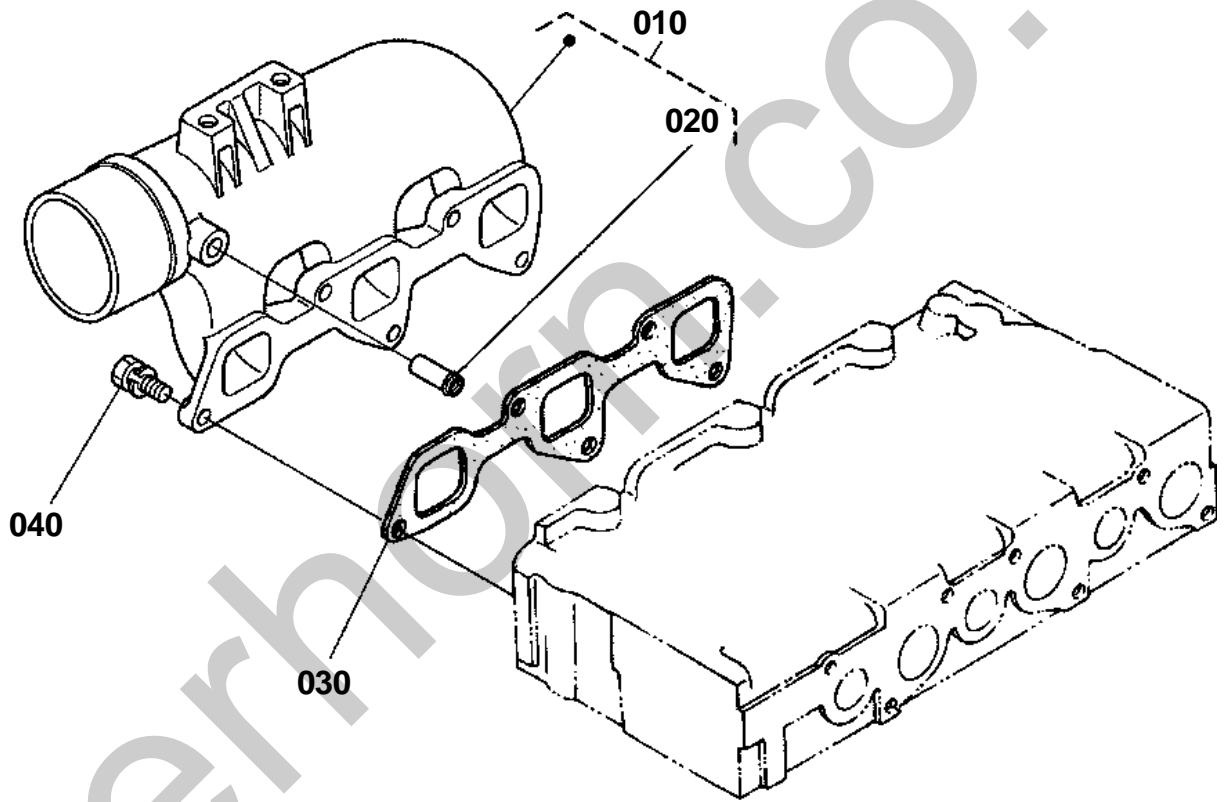

1G758-008-10



# INLET MANIFOLD

↔ Interchangeable; ≠ not interchangeable; ← new for old; → old for new

REF.No	Part No.	Description	Q'ty	S.No.	I/C	REMARKS	Weight (kgf)	Weight (lb)
010	1G751-11772	ASSY MANIFOLD INLET	1				0.9	1.98
020	17331-73342	PIPE WATER RETURN	1				0.01	0.022
030	1A021-11822	GASKET IN-MANIFOLD	1				0.006	0.0132
040	01123-50822	BOLT	5				0.012	0.0264

EXHAUST MANIFOLD/MUFFLER

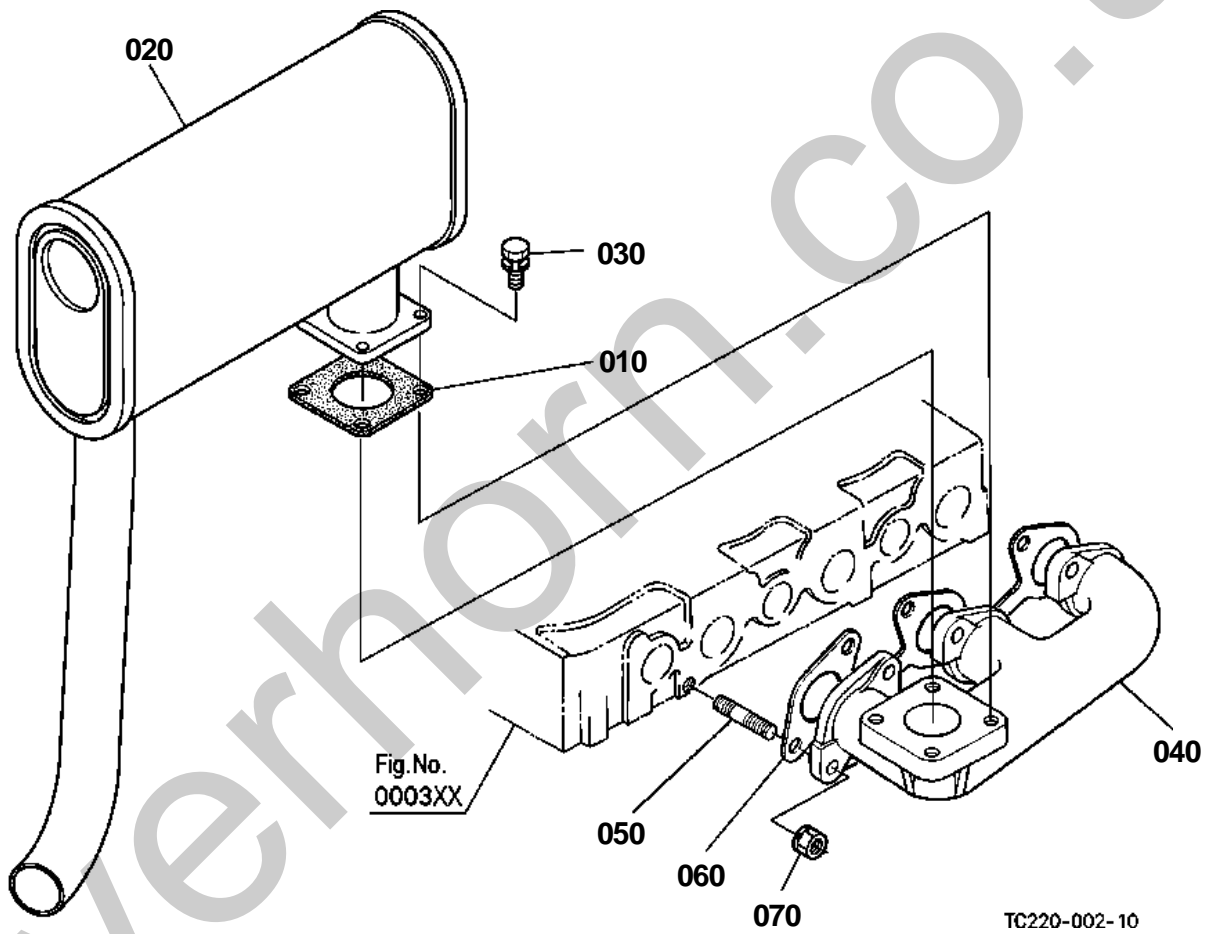



## EXHAUST MANIFOLD/MUFFLER

↔ Interchangeable; ≠ not interchangeable; ← new for old; → old for new

REF.No	Part No.	Description	Q'ty	S.No.	I/C	REMARKS	Weight (kgf)	Weight (lb)
010	T0070-16420	GASKET MUFFLER	1				0.016	0.0352
020	TC220-16410	MUFFLER	1				6.3	13.86
030	01128-50825	BOLT	4				0.015	0.033
040	17367-12313	MANIFOLD EXHAUST	1				2	4.4
050	15221-91530	STUD	6				0.011	0.0242
060	1A021-12350	GASKET EX-MANIFOLD	1				0.028	0.0616
070	16429-92010	NUT	6				0.007	0.0154



AIR CLEANER

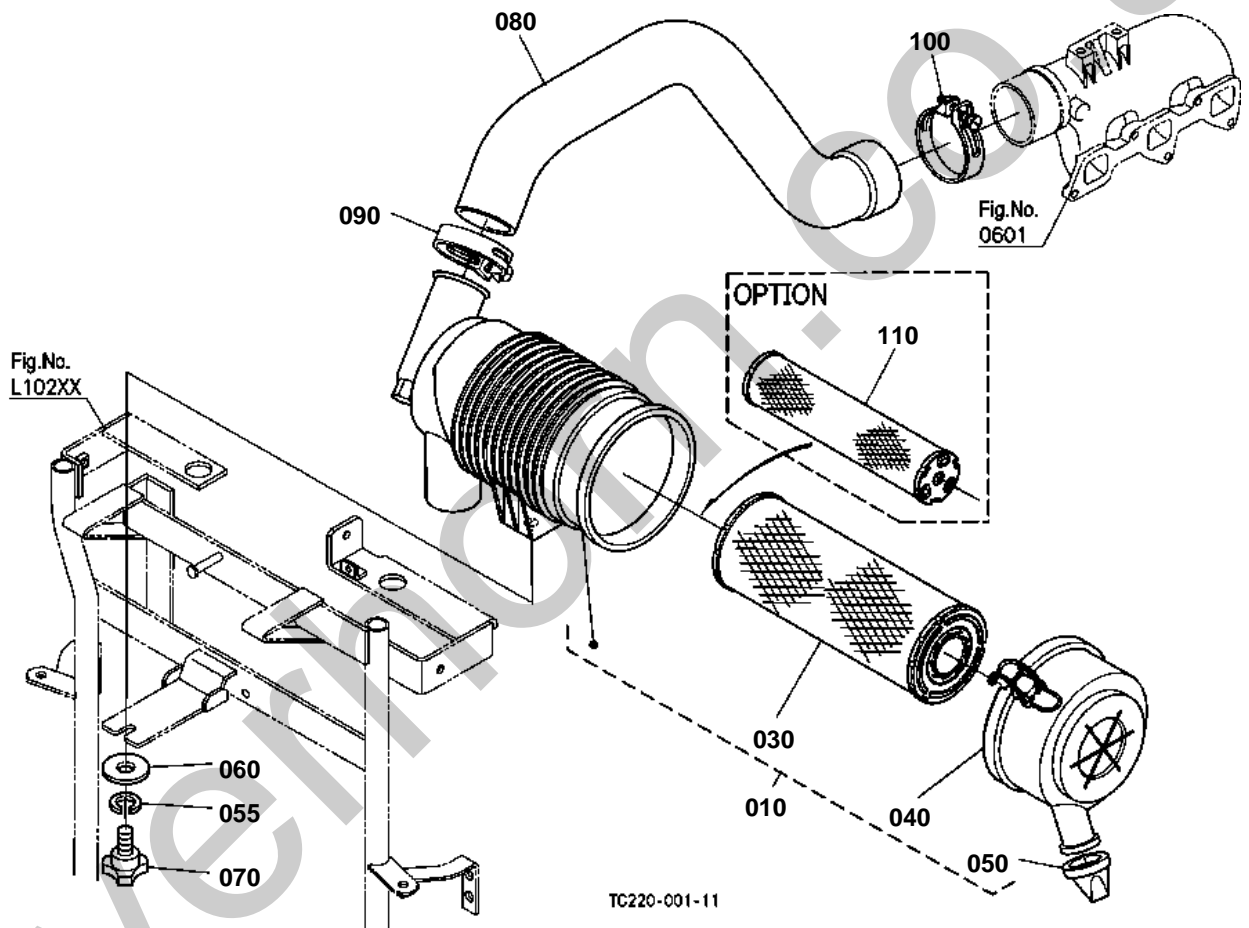



# AIR CLEANER

↔ Interchangeable; ≠ not interchangeable; ← new for old; → old for new

REF.No	Part No.	Description	Q'ty	S.No.	I/C	REMARKS	Weight (kgf)	Weight (lb)
010	TC220-16300	ASSY CLEANER AIR	1				1.35	2.97
020	99999-99999	BLANK	0				0	0
030	TA040-93230	ASSY ELEMENT OUTER	1				0.56	1.232
040	TA140-93240	ASSY COVER A/C	1				0.305	0.671
050	TA040-93250	VALVE EVACUATOR	1				0.011	0.0242
055	04512-60080	WASHER SPRING	1	>=50685			0.002	0.0044
060	04015-60080	WASHER PLAIN	1				0.01	0.022
070	01820-50815	BOLT KNOB	1	<=50684			0.026	0.0572
070	01820-50820	BOLT KNOB	1	>=50685	-		0.029	0.0638
080	TC220-16332	HOSE	1				0.725	1.595
090	T0270-35560	CLAMP HOSE	1				0.035	0.077
100	31351-18110	BAND PIPE	1				0.04	0.088
110	TA040-93220	ASSY ELEMENT INNER	1			OPTION	0.195	0.429

UPPER GASKET KIT

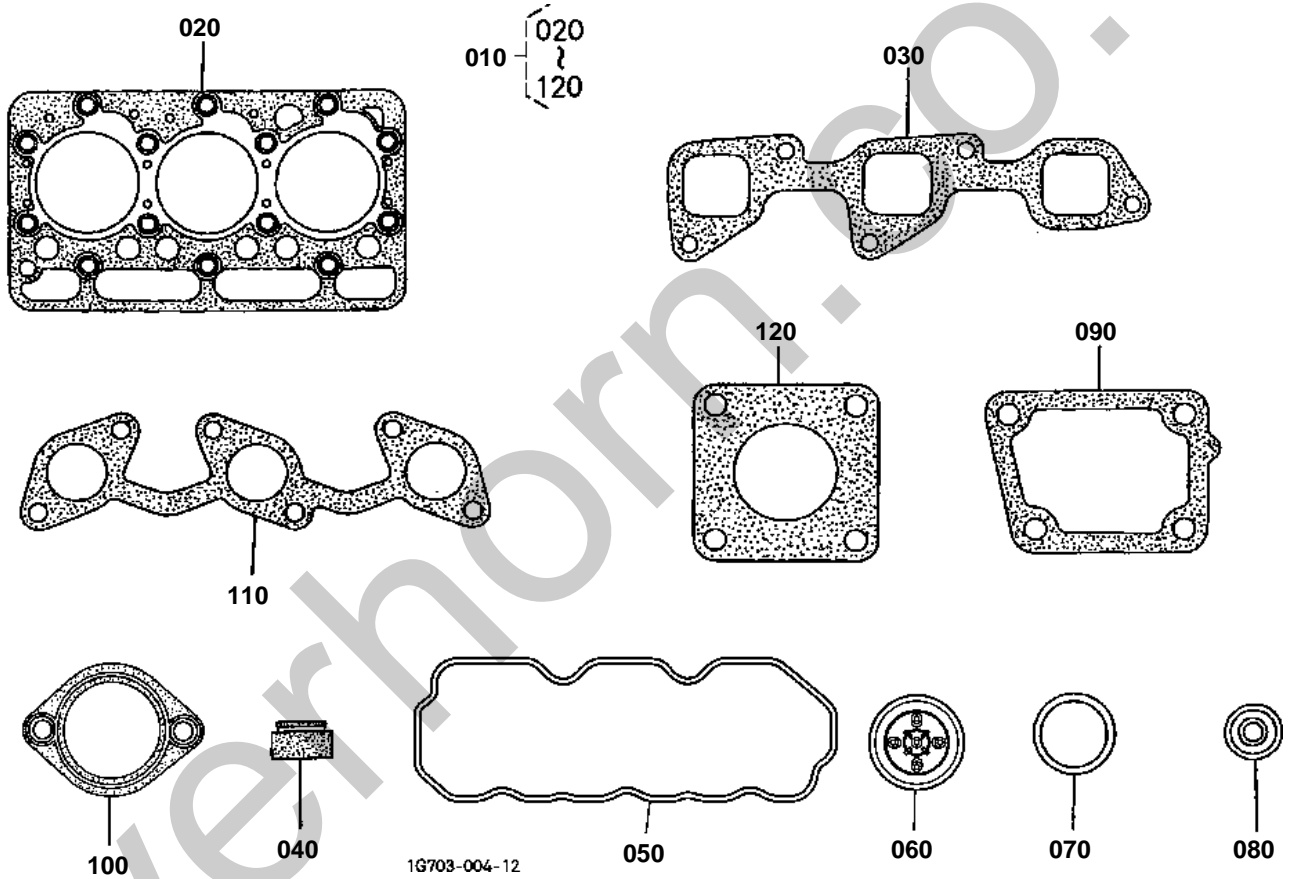

## OLD PARTS

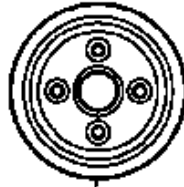

060

Silverhorn.CO.UK

1G758-802-10



## UPPER GASKET KIT

↔ Interchangeable; ≠ not interchangeable; ← new for old; → old for new

REF.No	Part No.	Description	Q'ty	S.No.	I/C	REMARKS	Weight (kgf)	Weight (lb)
010	1G703-99350	KIT GASKET UPPER	1	<=4J0878			0	0
010	1G703-99352	KIT GASKET UPPER	1	>=4L0001	→		0.24	0.528
010	1G703-99353	KIT GASKET UPPER	1	>=5A0001	→		0.24	0.528
010	1G703-99354	KIT GASKET UPPER	1	>=5G0001	→		0.24	0.528
020	16427-03310	GASKET CYLINDER HEAD	1				0.11	0.242
030	1A021-11822	GASKET IN-MANIFOLD	1				0.006	0.0132
040	15221-13153	SEAL VALVE STEM	6				0.001	0.0022
050	1A021-14520	GASKET HEAD COVER	1	<=4Y0983			0	0
050	1A021-14523	GASKET HEAD COVER	1	>=5A0001	→		0	0
060	1G911-05200	COMP.VALVE BREATHER	1	<=4J0878			0	0
060	1G911-05202	COMP.VALVE BREATHER	1	>=4L0001	→		0	0
060	1G911-05203	COMP.VALVE BREATHER	1	>=5G0001	→		0.01	0.022
070	15841-53622	GASKET	3				0.002	0.0044
080	19077-53650	SEAL HEAT	3				0.005	0.011
090	1A021-72920	GASKET WATER FLANGE	1				0.002	0.0044
100	16221-73270	GASKET THERMOSTAT	1				0.01	0.022
110	1A021-12350	GASKET EX-MANIFOLD	1				0.028	0.0616
120	T0070-16420	GASKET MUFFLER	1				0.016	0.0352

LOWER GASKET KIT

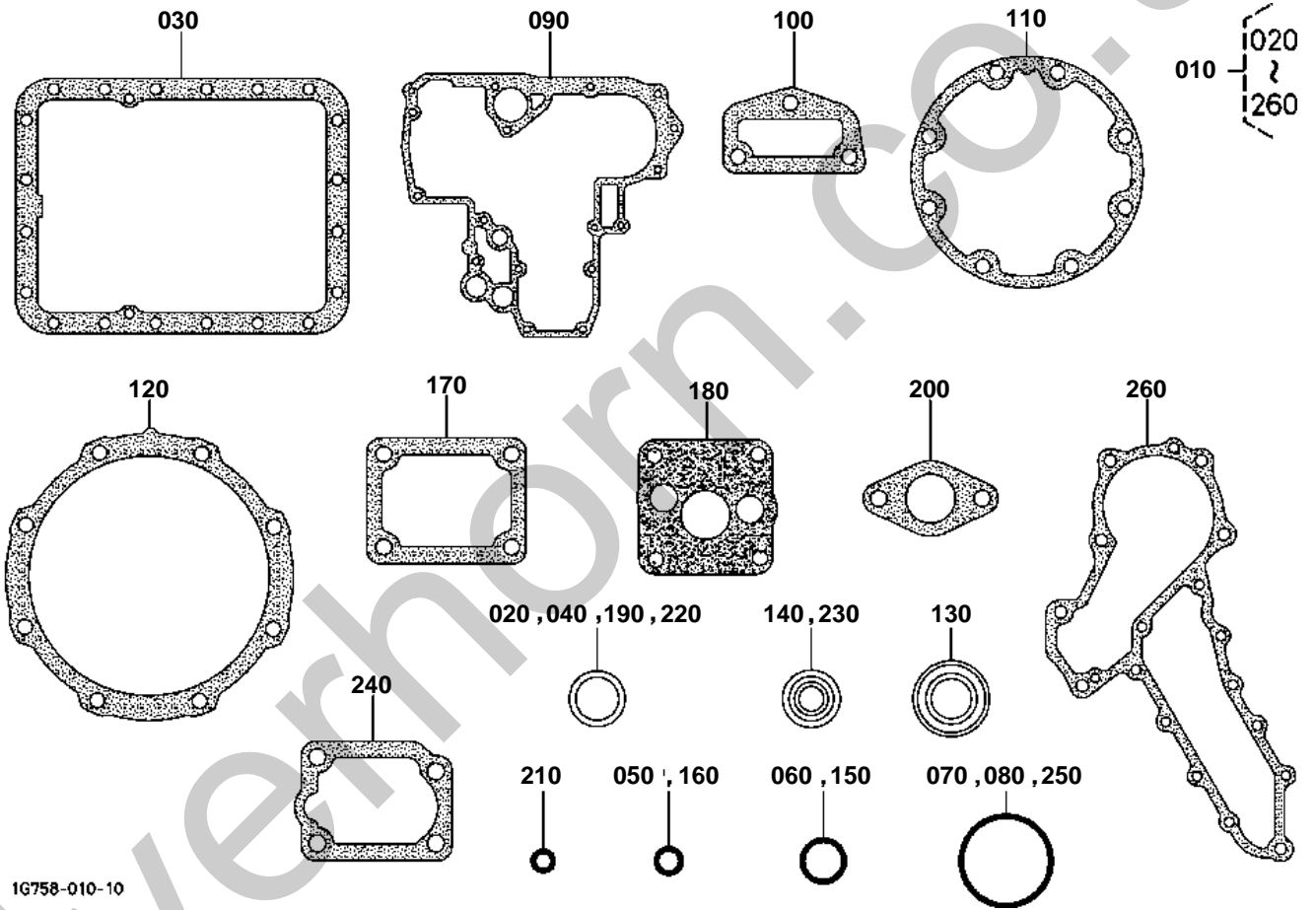

**LOWER GASKET KIT**

↔ Interchangeable; ≠ not interchangeable; ← new for old; → old for new

REF.No	Part No.	Description	Q'ty	S.No.	I/C	REMARKS	Weight (kgf)	Weight (lb)
010	1G703-99360	KIT GASKET LOWER	1				0.17	0.374
020	15021-33660	GASKET	1				0.001	0.0022
030	1A021-01620	GASKET OIL PAN	1				0.014	0.0308
040	6C090-58960	GASKET	2				0.002	0.0044
050	04817-00150	O RING	4				0.001	0.0022
060	04817-00220	O RING	2				0.001	0.0022
070	04817-00360	O RING	1				0.001	0.0022
080	19202-96830	O RING	1				0.01	0.022
090	1A021-04130	GASKET GEAR CASE	1				0.019	0.0418
100	1A021-73330	GASKET RETURN FLANGE	1				0.001	0.0022
110	1A091-04362	GASKET BEARING CASE	1				0.005	0.011
120	1A091-04820	GASKET CASE COVER	1				0.006	0.0132
130	19202-04460	SEAL OIL	1				0.055	0.121
140	19202-04140	SEAL OIL	1				0.015	0.033
150	04811-10300	O RING	1				0.001	0.0022
160	04817-00160	O RING	1				0.001	0.0022
170	1A021-51660	GASKET PUMP COVER	1				0.003	0.0066
180	1A021-35150	GASKET OIL PUMP	1				0.001	0.0022
190	15221-96650	GASKET	2				0.001	0.0022
200	1A021-52140	GASKET FUEL PUMP	1				0.001	0.0022
200	1G751-52140	GASKET FUEL PUMP	1		«		0.001	0.0022
210	04814-00060	O RING	1				0.001	0.0022
220	04724-00140	GASKET	1				0.002	0.0044
230	15471-57980	SEAL OIL	2				0.001	0.0022
240	1A021-57210	GASKET PLATE	2				0.001	0.0022
250	04814-06310	O RING	1				0.002	0.0044
260	1A021-73430	GASKET WATER PUMP	1				0.007	0.0154

ACCELERATOR LEVER [EXCEPT HST TYPE]

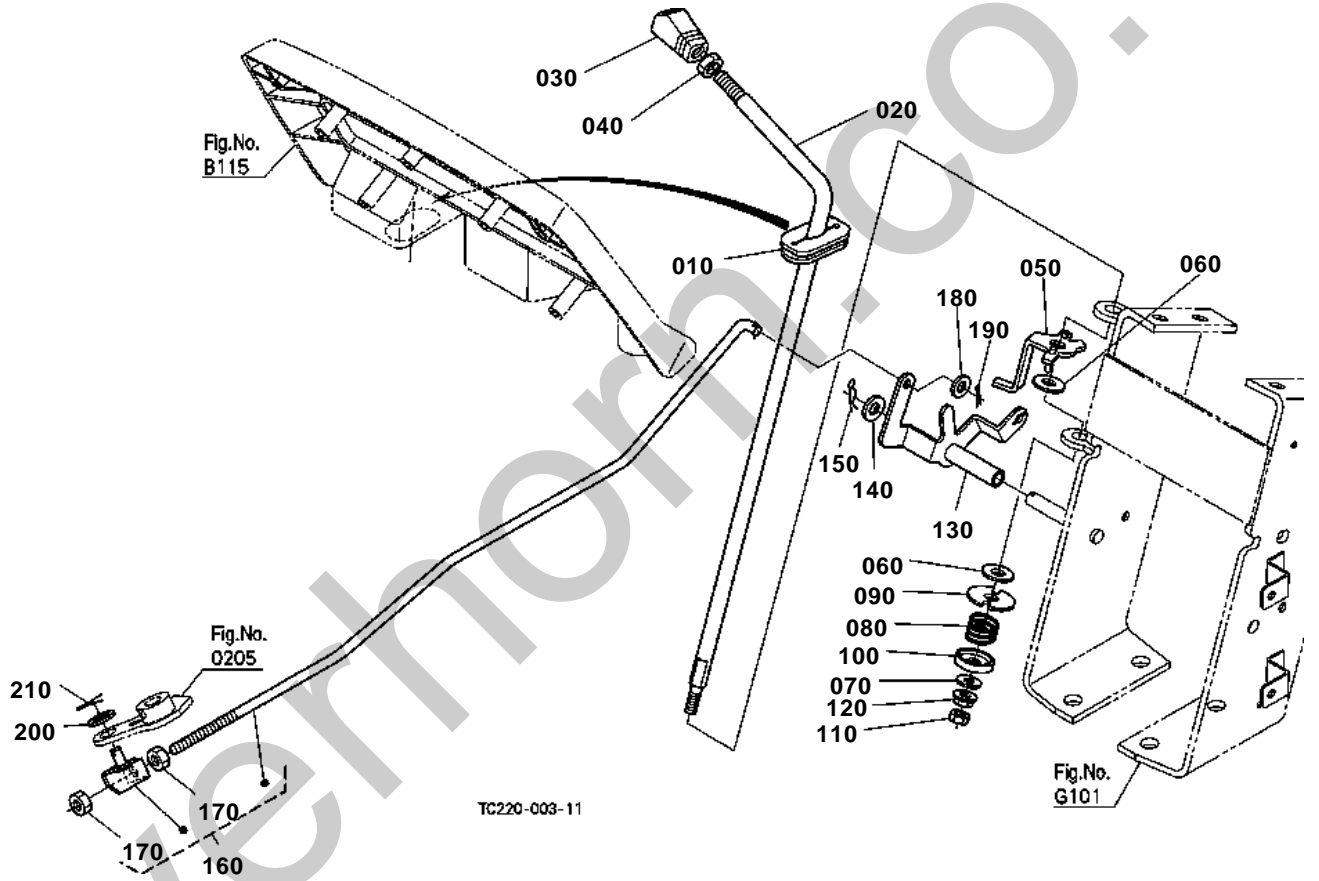



## OLD PARTS

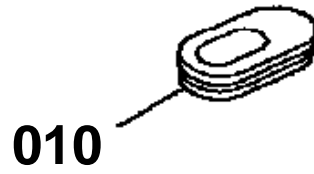

Silverhorn.CO.UK

TC220-800-10

**ACCELERATOR LEVER [EXCEPT HST TYPE]**

↔ Interchangeable; ≠ not interchangeable; ← new for old; → old for new

REF.No	Part No.	Description	Q'ty	S.No.	I/C	REMARKS	Weight (kgf)	Weight (lb)
010	TC020-43154	GROMMET HAND ACCEL.	1	<=50684			0.007	0.0154
010	TC020-43155	GROMMET HAND ACCEL.	1	>=50685	-		0.007	0.0154
020	TC220-17120	LEVER HAND ACCEL.	1				0.42	0.924
030	3F740-10680	GRIP LEVER	1				0.026	0.0572
040	30400-15210	NUT	1				0.005	0.011
050	TC050-44720	LEVER ACCEL.ARM	1				0.07	0.154
060	TD060-42870	PLATE ACCEL	2				0.01	0.022
070	04015-60080	WASHER PLAIN	1				0.01	0.022
080	33251-10320	SPRING ACCEL.LEVER	1				0.012	0.0264
090	T1060-42840	WASHER	1				0.02	0.044
100	TC050-10270	CAP SPRING	1				0.023	0.0506
110	02114-50080	NUT	1				0.005	0.011
120	02751-50080	NUT FLANGE	1				0.006	0.0132
130	TC220-17320	LINK ACCEL.	1				0.13	0.286
140	04013-60100	WASHER PLAIN	1				0.003	0.0066
150	05515-61000	PIN SNAP	1				0.002	0.0044
160	TC220-42890	ASSY ROD ACCEL.	1				0.225	0.495
170	02112-50080	NUT	2				0.003	0.0066
180	04012-50080	WASHER PLAIN	1				0.001	0.0022
190	05511-50218	PIN SPLIT	1				0.001	0.0022
200	04012-50060	WASHER PLAIN	1				0.001	0.0022
210	05511-51615	PIN SPLIT	1				0.001	0.0022

ACCELERATOR LEVER [HST TYPE]

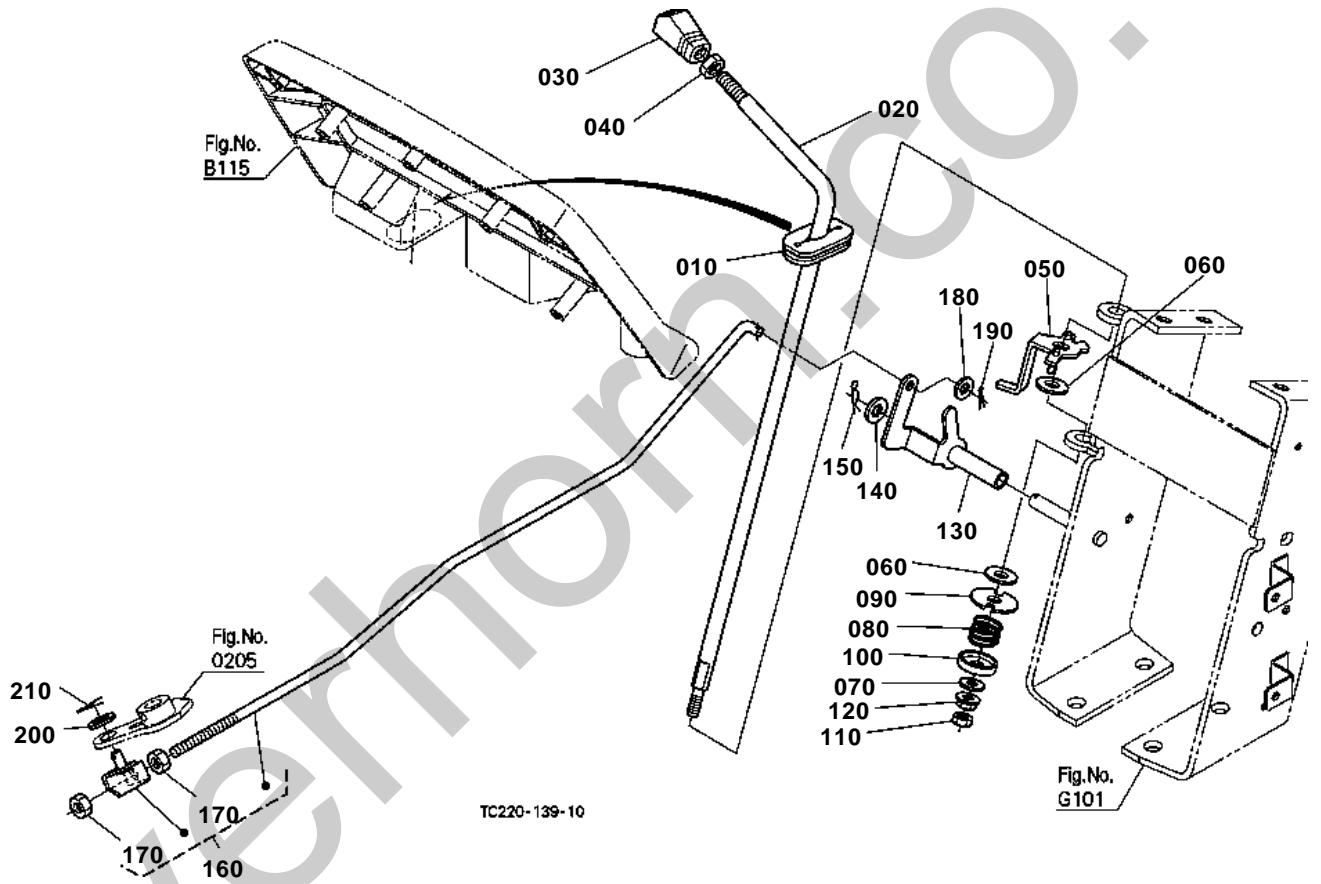

**ACCELERATOR LEVER [HST TYPE]**

↔ Interchangeable; ≠ not interchangeable; ← new for old; → old for new

REF.No	Part No.	Description	Q'ty	S.No.	I/C	REMARKS	Weight (kgf)	Weight (lb)
010	TC020-43155	GROMMET HAND ACCEL.	1				0.007	0.0154
020	TC220-17120	LEVER HAND ACCEL.	1				0.42	0.924
030	3F740-10680	GRIP LEVER	1				0.026	0.0572
040	30400-15210	NUT	1				0.005	0.011
050	TC050-44720	LEVER ACCEL.ARM	1				0.07	0.154
060	TD060-42870	PLATE ACCEL	2				0.01	0.022
070	04015-60080	WASHER PLAIN	1				0.01	0.022
080	33251-10320	SPRING ACCEL.LEVER	1				0.012	0.0264
090	T1060-42840	WASHER	1				0.02	0.044
100	TC050-10270	CAP SPRING	1				0.023	0.0506
110	02114-50080	NUT	1				0.005	0.011
120	02751-50080	NUT FLANGE	1				0.006	0.0132
130	TC220-55410	LINK ACCELERATOR	1				0	0
140	04013-60100	WASHER PLAIN	1				0.003	0.0066
150	05515-61000	PIN SNAP	1				0.002	0.0044
160	TC220-42890	ASSY ROD ACCEL.	1				0.225	0.495
170	02112-50080	NUT	2				0.003	0.0066
180	04012-50080	WASHER PLAIN	1				0.001	0.0022
190	05511-50218	PIN SPLIT	1				0.001	0.0022
200	04012-50060	WASHER PLAIN	1				0.001	0.0022
210	05511-51615	PIN SPLIT	1				0.001	0.0022

ACCELERATOR LINKAGE [EXCEPT HST TYPE]

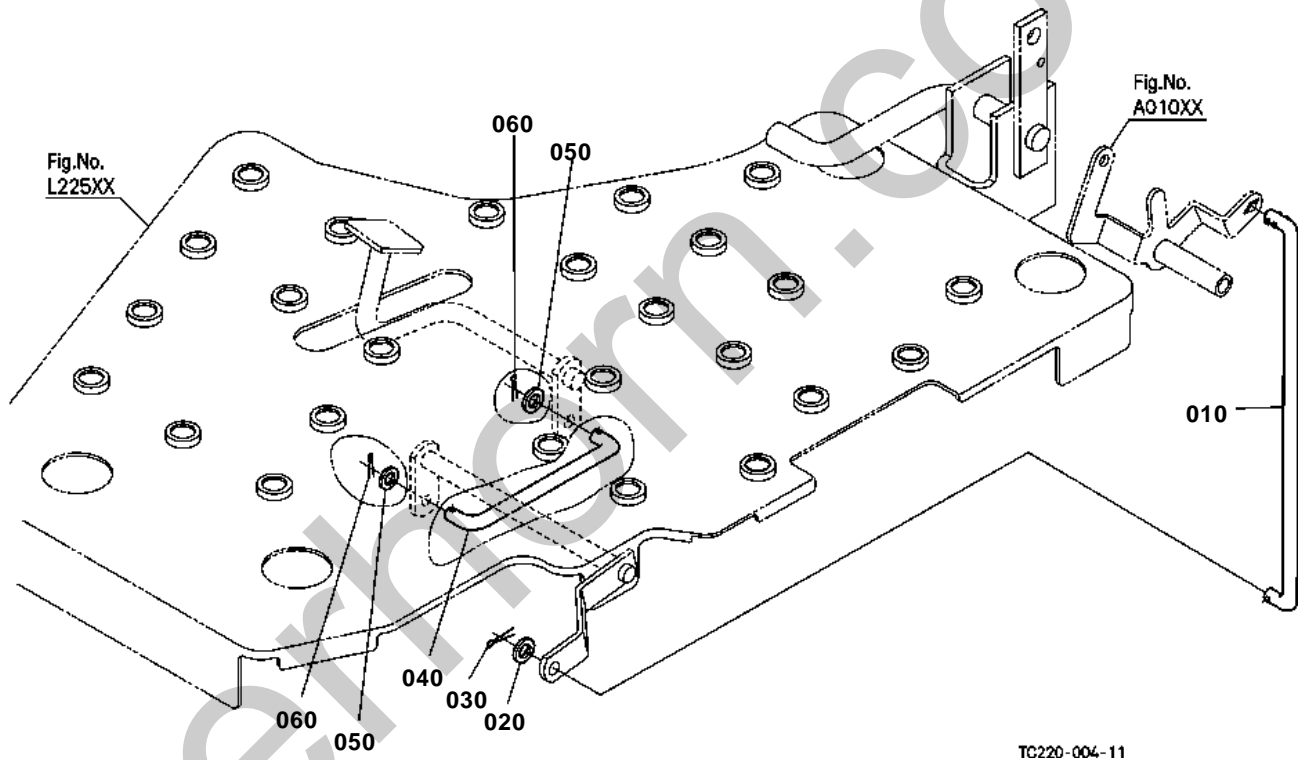

TC220-004-11



# ACCELERATOR LINKAGE [EXCEPT HST TYPE]

↔ Interchangeable; ≠ not interchangeable; ← new for old; → old for new

REF.No	Part No.	Description	Q'ty	S.No.	I/C	REMARKS	Weight (kgf)	Weight (lb)
010	TC220-17570	ROD ACCEL.	1				0.09	0.198
020	04012-50080	WASHER PLAIN	1				0.001	0.0022
030	05511-50218	PIN SPLIT	1	<=52262			0.001	0.0022
030	05511-52520	PIN SPLIT	1	>=52263	-		0.001	0.0022
040	TC220-17580	ROD ACCEL.	1				0.03	0.066
050	04012-50060	WASHER PLAIN	2				0.001	0.0022
060	05511-50212	PIN SPLIT	2				0.001	0.0022

FUEL TANK

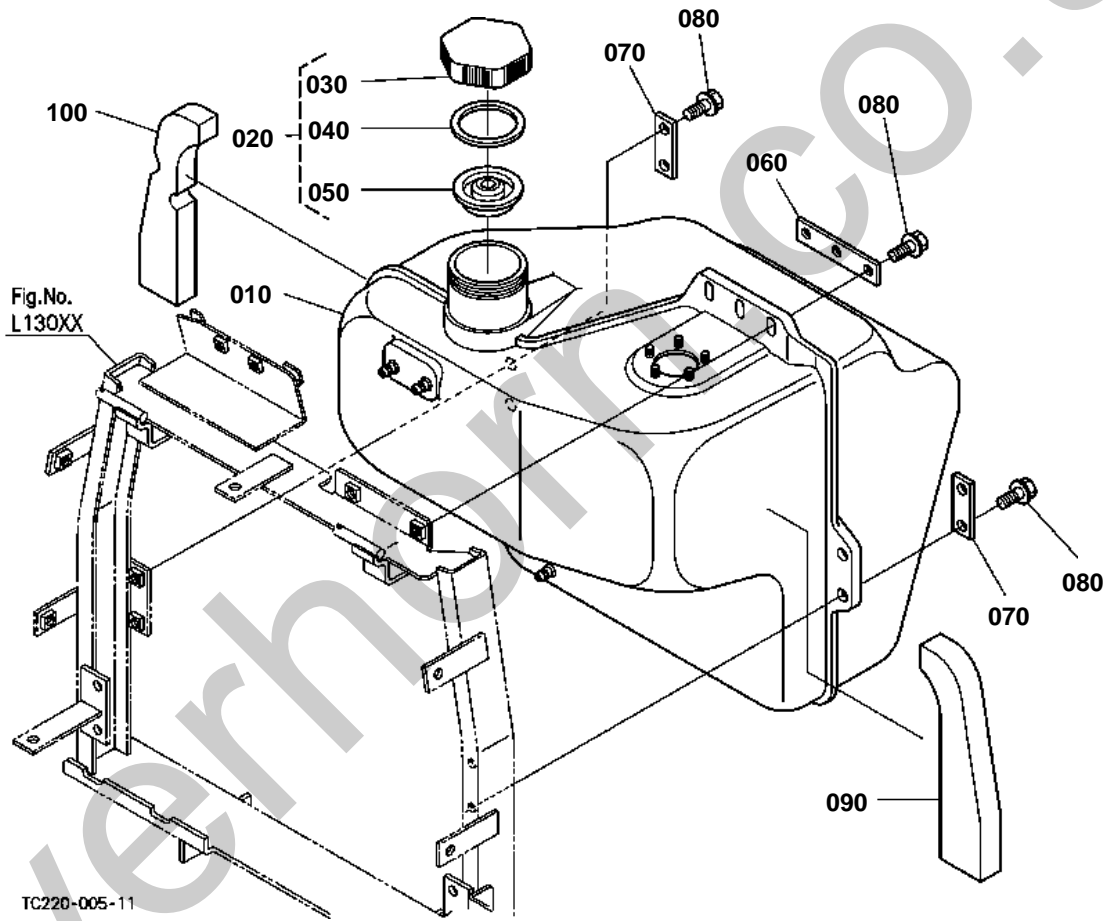

**FUEL TANK**

↔ Interchangeable; ≠ not interchangeable; ← new for old; → old for new

REF.No	Part No.	Description	Q'ty	S.No.	I/C	REMARKS	Weight (kgf)	Weight (lb)
010	TC220-42010	TANK FUEL	1				4	8.8
020	6A100-54910	ASSY CAP FUEL	1				0.105	0.231
030	6A100-54920	CAP FUEL	1				0.041	0.0902
040	6A100-54942	SPACER	1				0.001	0.0022
050	6A100-54952	GASKET	1				0.02	0.044
060	TC020-42120	PLATE FUEL TANK	1				0.013	0.0286
070	T1060-42080	PLATE FUEL TANK	2				0.033	0.0726
080	01123-50825	BOLT	6				0.013	0.0286
090	TC220-42180	SPONGE	1				0.04	0.088
100	TC220-42190	SPONGE SHUTTER RH	1	>=52581			0.035	0.077





## OLD PARTS

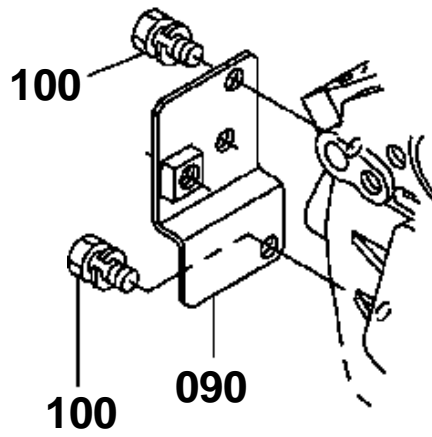

Silverhorn.CO.UK

TC220-830-20

**FUEL PIPE AND FUEL FILTER [EXCEPT HST TYPE]**

↔ Interchangeable; ≠ not interchangeable; ← new for old; → old for new

REF.No	Part No.	Description	Q'ty	S.No.	I/C	REMARKS	Weight (kgf)	Weight (lb)
010	6A320-58862	ASSY FILTER FUEL	1				0.09	0.198
020	T1060-42620	ASSY TUBE FUEL	1				0.1	0.22
030	09664-80650	TUBE FUEL	1				0.08	0.176
040	09318-88125	CLAMP HOSE	2				0.001	0.0022
050	T0180-42640	ASSY PIPE FUEL	1				0.05	0.11
060	09661-40600	TUBE FUEL	1				0.03	0.066
070	14971-42750	CLIP PIPE	2				0.001	0.0022
080	01123-50825	BOLT	1				0.013	0.0286
090	TC220-16560	STAY FUEL FILTER	1	<=52580			0.062	0.1364
090	TC220-16562	STAY FUEL FILTER	1	>=52581	→		0.08	0.176
100	01023-50612	BOLT	2	<=53276			0.005	0.011
100	01754-50610	BOLT FLANGE	2	>=53277	→		0.006	0.0132
110	TA470-42610	ASSY TUBE FUEL	1				0.08	0.176
120	37410-88230	PIPE FUEL	1				0.072	0.1584
130	09318-88125	CLAMP HOSE	2				0.001	0.0022
140	T0180-42640	ASSY PIPE FUEL	1				0.05	0.11
150	09661-40600	TUBE FUEL	1				0.03	0.066
160	14971-42750	CLIP PIPE	2				0.001	0.0022

FUEL PIPE AND FUEL FILTER [HST TYPE]

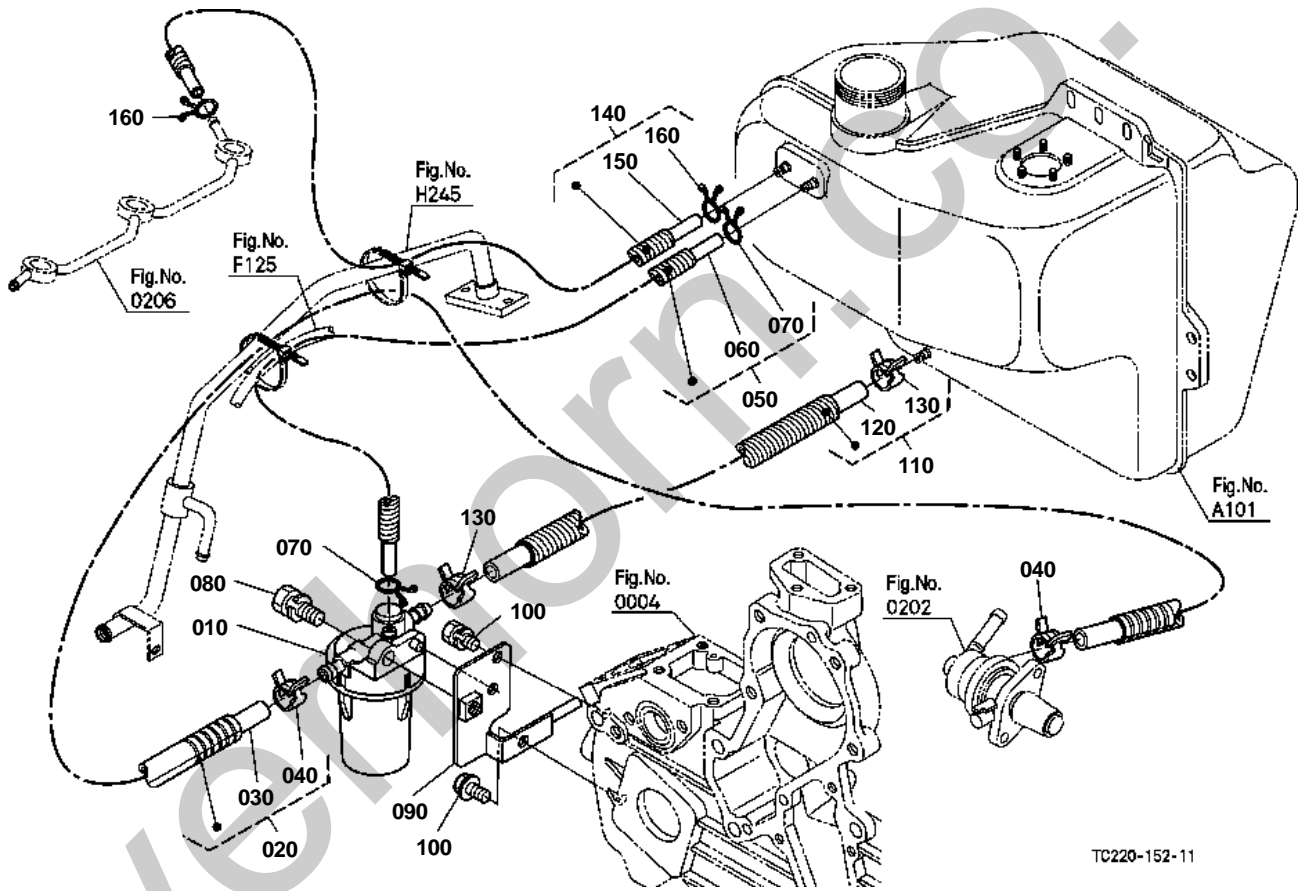

## OLD PARTS

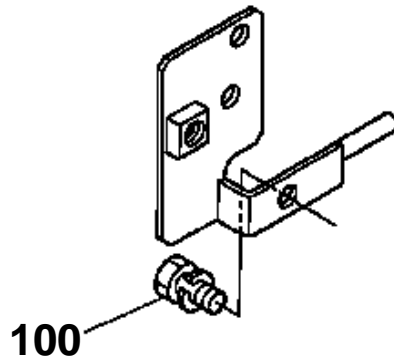

Silverhorn.CO.UK

TC220-847-10

**FUEL PIPE AND FUEL FILTER [HST TYPE]**

↔ Interchangeable; ≠ not interchangeable; ← new for old; → old for new

REF.No	Part No.	Description	Q'ty	S.No.	I/C	REMARKS	Weight (kgf)	Weight (lb)
010	6A320-58862	ASSY FILTER FUEL	1				0.09	0.198
020	T1060-42620	ASSY TUBE FUEL	1				0.1	0.22
030	09664-80650	TUBE FUEL	1				0.08	0.176
040	09318-88125	CLAMP HOSE	2				0.001	0.0022
050	T0180-42640	ASSY PIPE FUEL	1				0.05	0.11
060	09661-40600	TUBE FUEL	1				0.03	0.066
070	14971-42750	CLIP PIPE	2				0.001	0.0022
080	01123-50825	BOLT	1				0.013	0.0286
090	TC220-16562	STAY FUEL FILTER	1				0.08	0.176
100	01023-50612	BOLT	2	<=53276			0.005	0.011
100	01754-50610	BOLT FLANGE	2	>=53277			0.006	0.0132
110	TA470-42610	ASSY TUBE FUEL	1				0.08	0.176
120	37410-88230	PIPE FUEL	1				0.072	0.1584
130	09318-88125	CLAMP HOSE	2				0.001	0.0022
140	T0180-42640	ASSY PIPE FUEL	1				0.05	0.11
150	09661-40600	TUBE FUEL	1				0.03	0.066
160	14971-42750	CLIP PIPE	2				0.001	0.0022

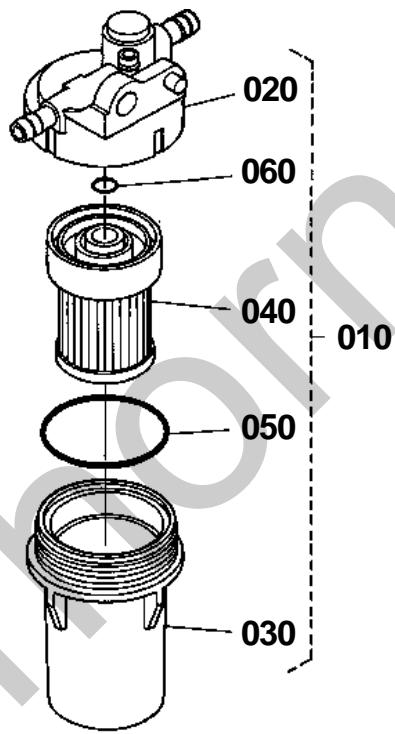

6A320-010-10



## FUEL FILTER [COMPONENT PARTS]

↔ Interchangeable; ≠ not interchangeable; ← new for old; → old for new

REF.No	Part No.	Description	Q'ty	S.No.	I/C	REMARKS	Weight (kgf)	Weight (lb)
010	6A320-58862	ASSY FILTER FUEL	1				0.09	0.198
020	6A320-59912	BODY	1			NOT SALE	0.035	0.077
030	6A320-59920	CUP	1				0.03	0.066
040	6A320-59930	FILTER	1				0.025	0.055
050	6A320-59940	O-RING	1				0.001	0.0022
060	6A320-59950	O-RING	1				0.001	0.0022



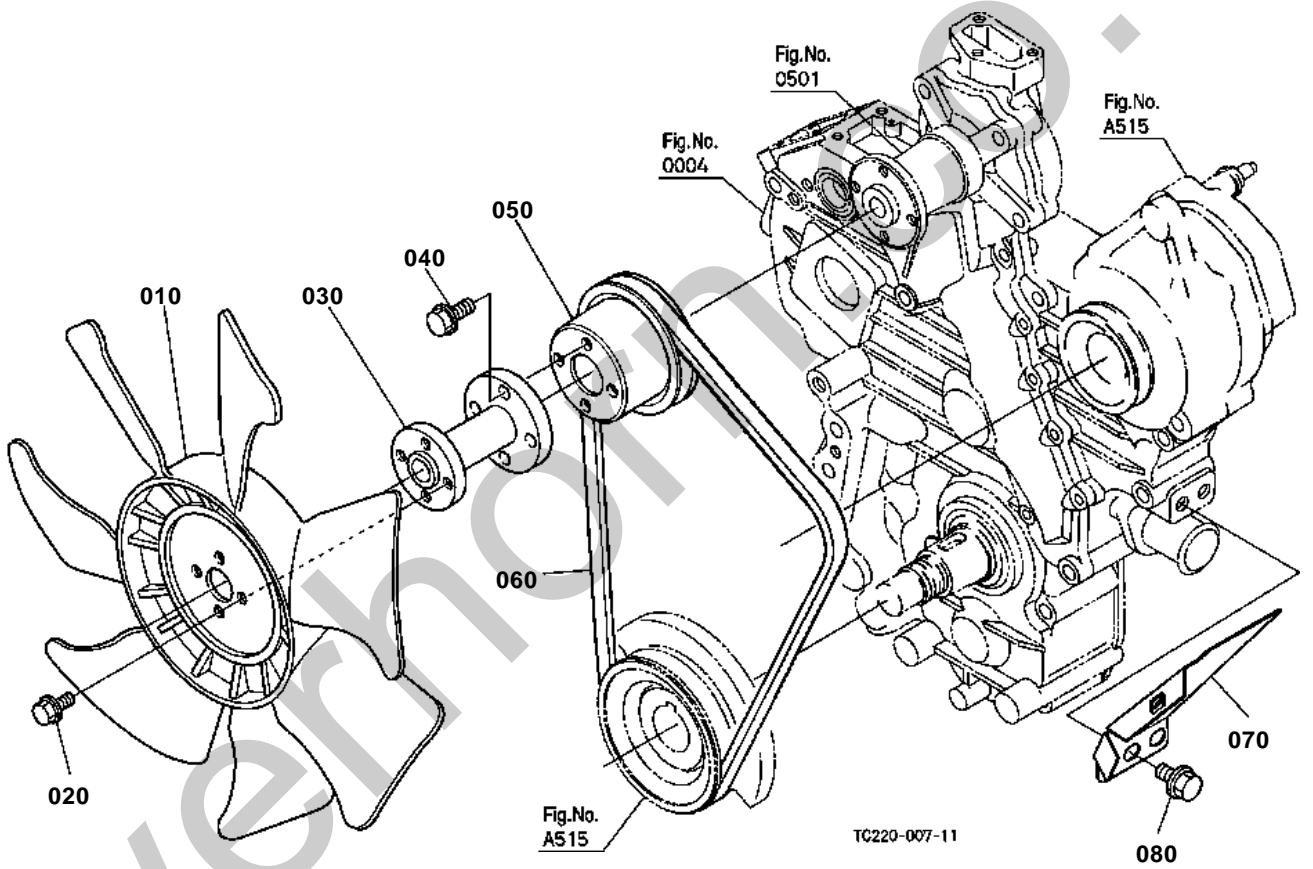

**FAN**

↔ Interchangeable; ≠ not interchangeable; ← new for old; → old for new

REF.No	Part No.	Description	Q'ty	S.No.	I/C	REMARKS	Weight (kgf)	Weight (lb)
010	34030-16210	FAN	1				0.96	2.112
020	01754-50612	BOLT FLANGE	4				0.005	0.011
030	T0070-16222	FLANGE FAN	1				0.195	0.429
040	01754-50625	BOLT FLANGE	4				0.008	0.0176
050	15471-74250	PULLEY FAN	1				0.3	0.66
060	15469-97010	V BELT A	1				0.095	0.209
070	TC220-16180	COVER	1				2	4.4
080	01754-50812	BOLT FLANGE	2				0.01	0.022

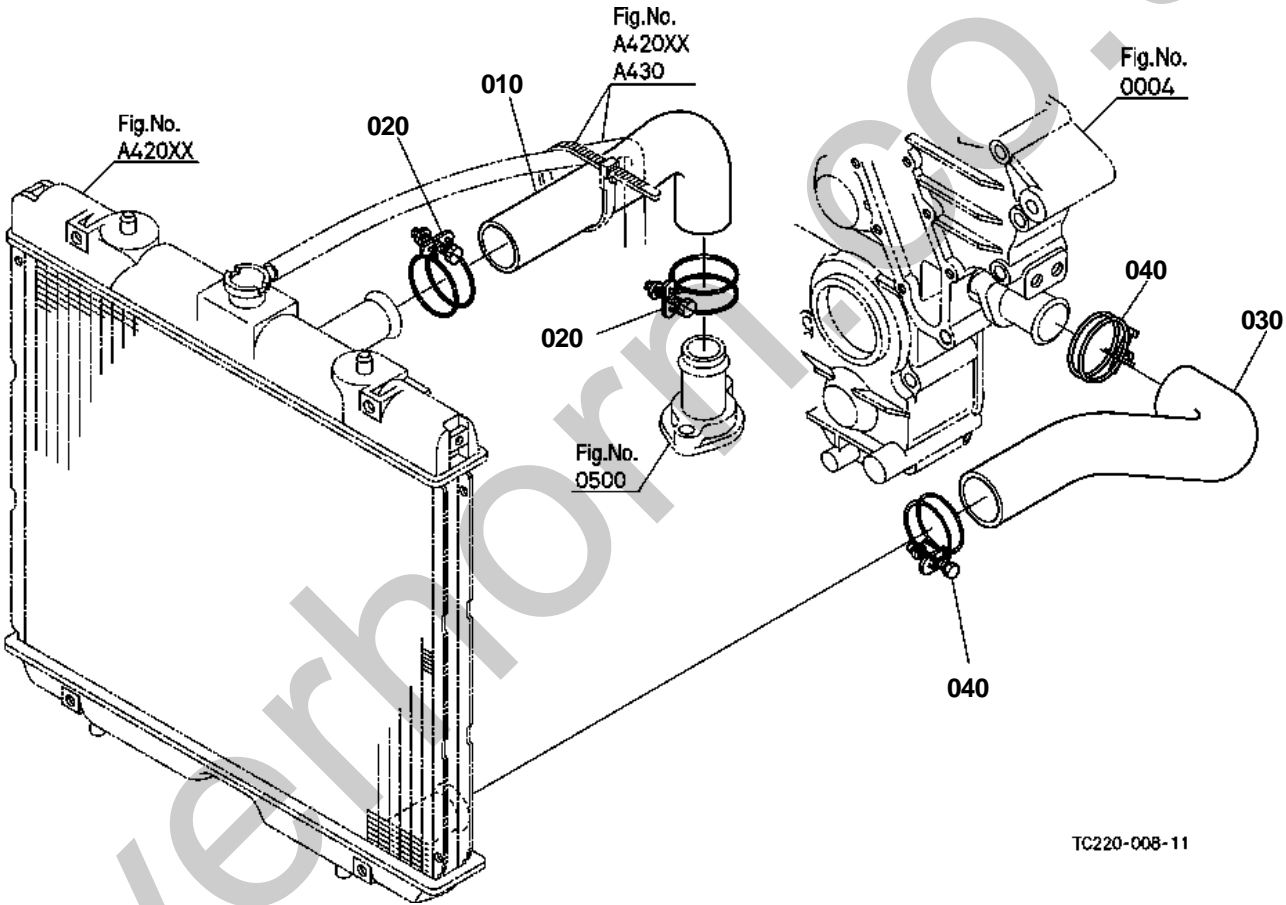

TC220-008-11



## WATER PIPE

↔ Interchangeable; ≠ not interchangeable; ← new for old; → old for new

REF.No	Part No.	Description	Q'ty	S.No.	I/C	REMARKS	Weight (kgf)	Weight (lb)
010	TC030-72940	PIPE WATER	1				0.22	0.484
020	15108-72870	BAND	2				0.027	0.0594
030	TC220-16140	HOSE RADIATOR LOWER	1				0.23	0.506
040	15108-72870	BAND	2				0.027	0.0594

RADIATOR [EXCEPT HST TYPE]

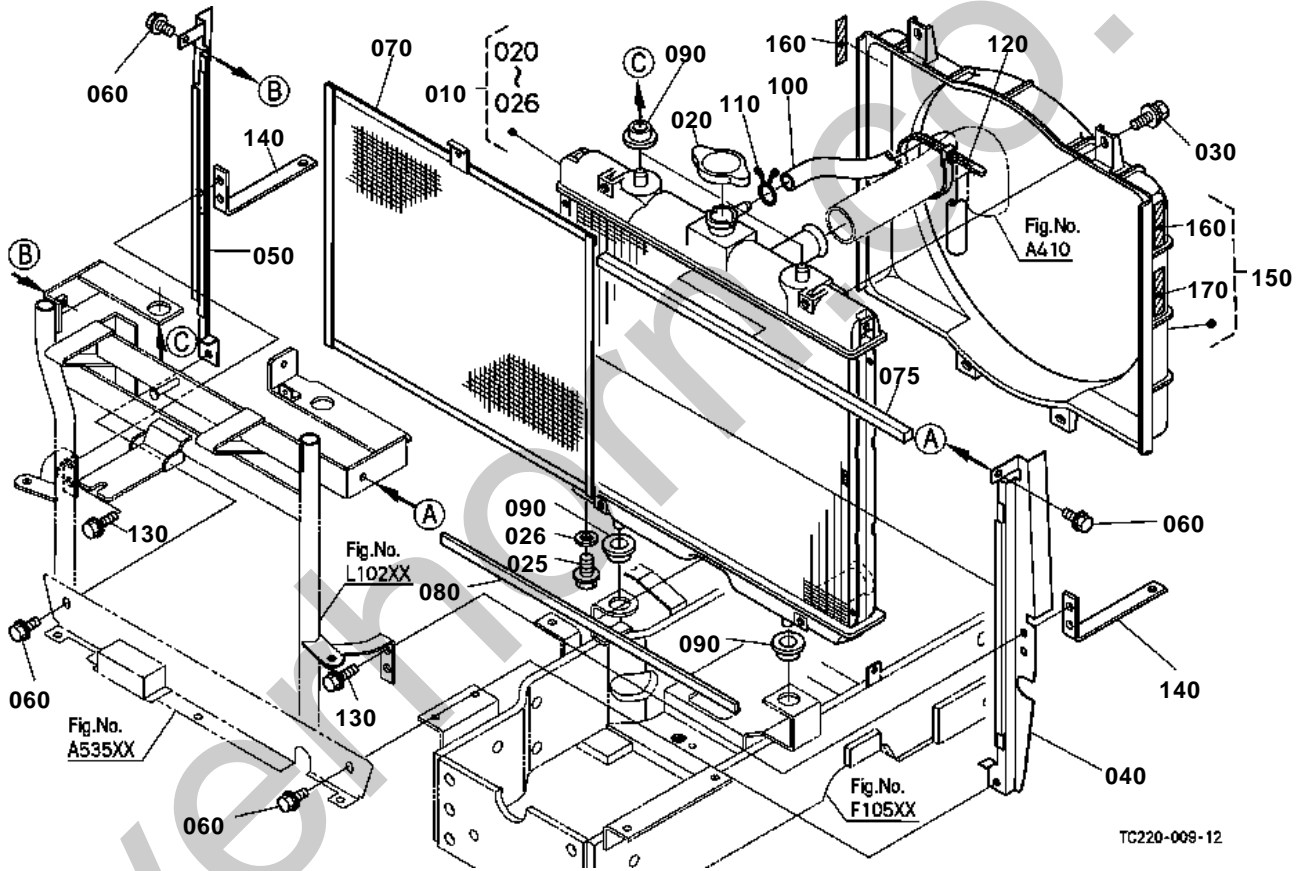

OLD PARTS

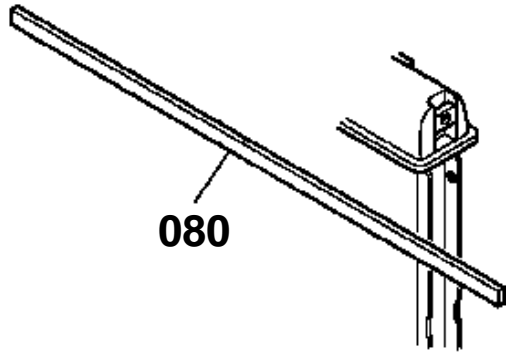

Silverhorn.CO.UK

TC220-850-10

**RADIATOR [EXCEPT HST TYPE]**

↔ Interchangeable; ≠ not interchangeable; ← new for old; → old for new

REF.No	Part No.	Description	Q'ty	S.No.	I/C	REMARKS	Weight (kgf)	Weight (lb)
010	TC020-16000	ASSY RADIATOR	1				2.7	5.94
020	17580-16060	CAP RADIATOR	1				0.04	0.088
025	T1060-16070	PLUG DRAIN	1				0.004	0.0088
026	15231-96690	GASKET	1				0.001	0.0022
030	01205-50616	BOLT	4	<=54355			0.007	0.0154
030	01025-50616	BOLT	4	>=54356	-		0.005	0.011
040	TC220-16040	GUIDE RADIATOR LH	1				0.26	0.572
050	TC220-16050	GUIDE RADIATOR RH	1				0.26	0.572
060	01754-50812	BOLT FLANGE	4				0.01	0.022
070	TC220-16240	NET RADIATOR	1				0.36	0.792
075	TC220-40660	SPONGE	1	>=57745			0	0
080	T1060-40660	SPONGE	2	<=57744			0.005	0.011
080	T1060-40660	SPONGE	1	>=57745			0.005	0.011
090	34070-16030	RUBBER	4				0.015	0.033
100	TC020-71940	PIPE WATER OVER FLOW	1				0.055	0.121
110	15501-72470	CLIP PIPE	1				0.005	0.011
120	55311-41260	BAND CORD	1				0.007	0.0154
130	01754-50816	BOLT FLANGE	4				0.011	0.0242
140	TC220-41400	STAY COVER	2				0.13	0.286
150	TC220-99620	KIT SHROUD	1				0	0
160	6C090-49580	LABEL FAN WARNING	2				0.001	0.0022
170	TC030-49580	LABEL MUFFLER	1				0.001	0.0022

RADIATOR [HST TYPE]

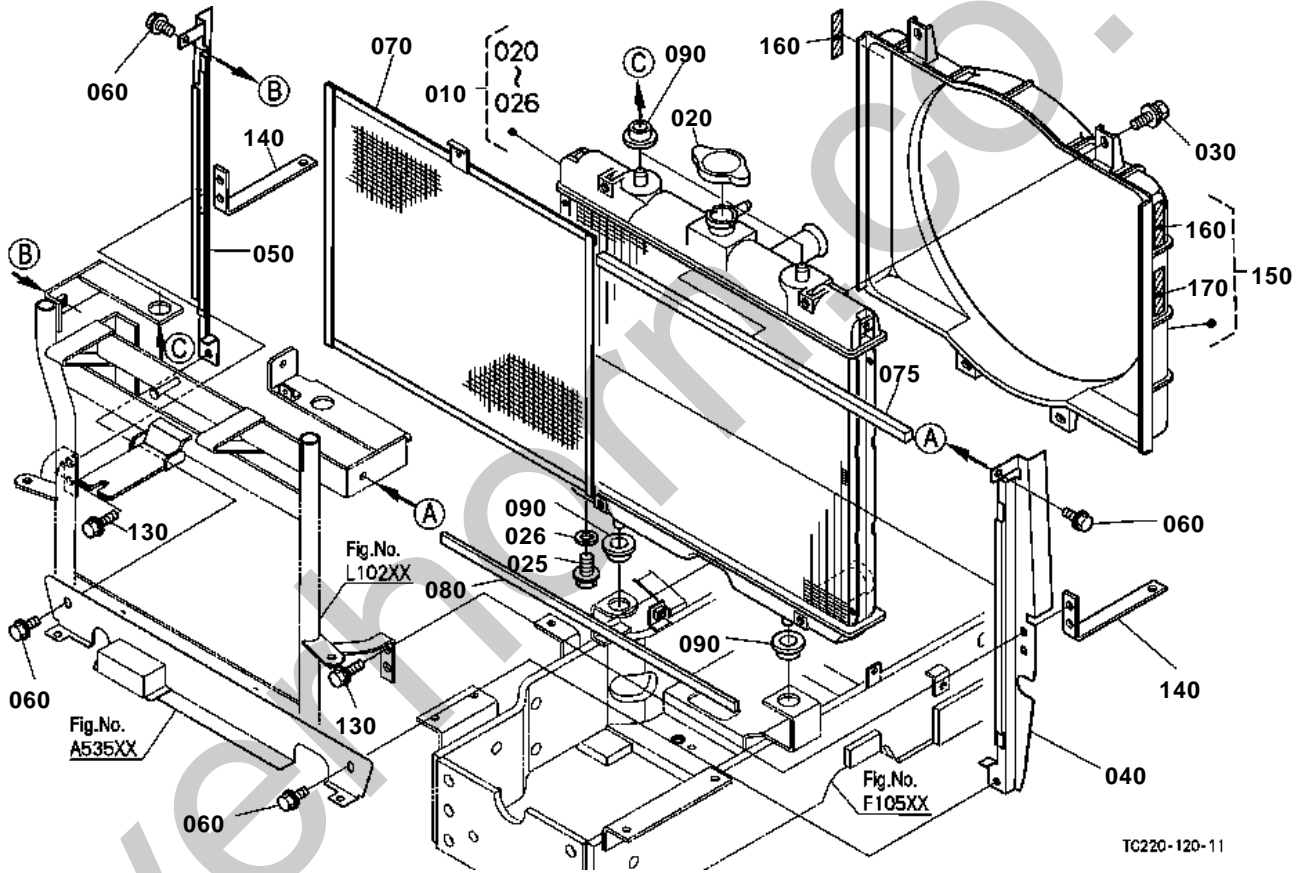



## OLD PARTS

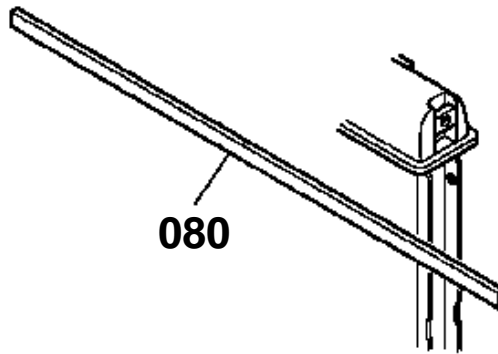

Silverhorn.co.uk

TC220-850-10

**RADIATOR [HST TYPE]**

↔ Interchangeable; ≠ not interchangeable; ← new for old; → old for new

REF.No	Part No.	Description	Q'ty	S.No.	I/C	REMARKS	Weight (kgf)	Weight (lb)
010	TC020-16000	ASSY RADIATOR	1				2.7	5.94
020	17580-16060	CAP RADIATOR	1				0.04	0.088
025	T1060-16070	PLUG DRAIN	1				0.004	0.0088
026	15231-96690	GASKET	1				0.001	0.0022
030	01205-50616	BOLT	4	<=54355			0.007	0.0154
030	01025-50616	BOLT	4	>=54356	-		0.005	0.011
040	TC220-16040	GUIDE RADIATOR LH	1				0.26	0.572
050	TC220-16050	GUIDE RADIATOR RH	1				0.26	0.572
060	01754-50812	BOLT FLANGE	4				0.01	0.022
070	TC220-16240	NET RADIATOR	1				0.36	0.792
075	TC220-40660	SPONGE	1	>=57745			0	0
080	T1060-40660	SPONGE	2	<=57744			0.005	0.011
080	T1060-40660	SPONGE	1	>=57745			0.005	0.011
090	34070-16030	RUBBER	4				0.015	0.033
100	99999-99999	BLANK	0				0	0
110	99999-99999	BLANK	0				0	0
120	99999-99999	BLANK	0				0	0
130	01754-50816	BOLT FLANGE	4				0.011	0.0242
140	TC220-41400	STAY COVER	2				0.13	0.286
150	TC220-99620	KIT SHROUD	1				0	0
160	6C090-49580	LABEL FAN WARNING	2				0.001	0.0022
170	TC030-49580	LABEL MUFFLER	1				0.001	0.0022

RESERVE TANK [HST TYPE]

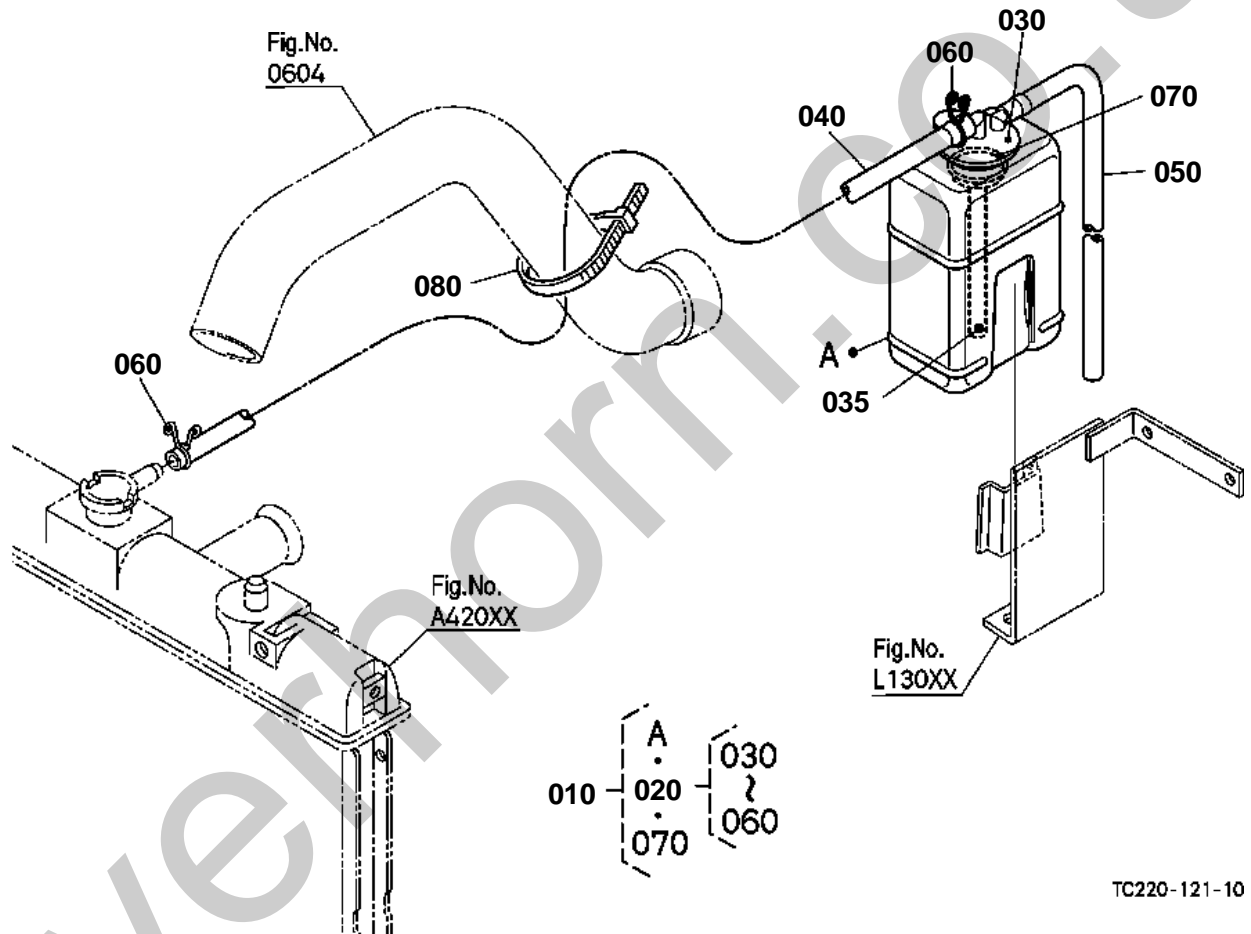

TC220-121-10



# RESERVE TANK [HST TYPE]

↔ Interchangeable; ≠ not interchangeable; ← new for old; → old for new

REF.No	Part No.	Description	Q'ty	S.No.	I/C	REMARKS	Weight (kgf)	Weight (lb)
010	37410-88603	ASSY TANK RESERVE	1				0.24	0.528
020	37410-88623	ASSY CAP	1				0.085	0.187
030	37410-88640	CAP	1				0.01	0.022
035	37410-88650	HOSE	1				0.014	0.0308
040	37410-88662	HOSE	1				0.055	0.121
050	37410-88670	HOSE	1				0.02	0.044
060	37410-88680	CLIP	2				0.003	0.0066
070	37410-88630	O RING	1				0.001	0.0022
080	55311-41260	BAND CORD	1				0.007	0.0154

ALTERNATOR

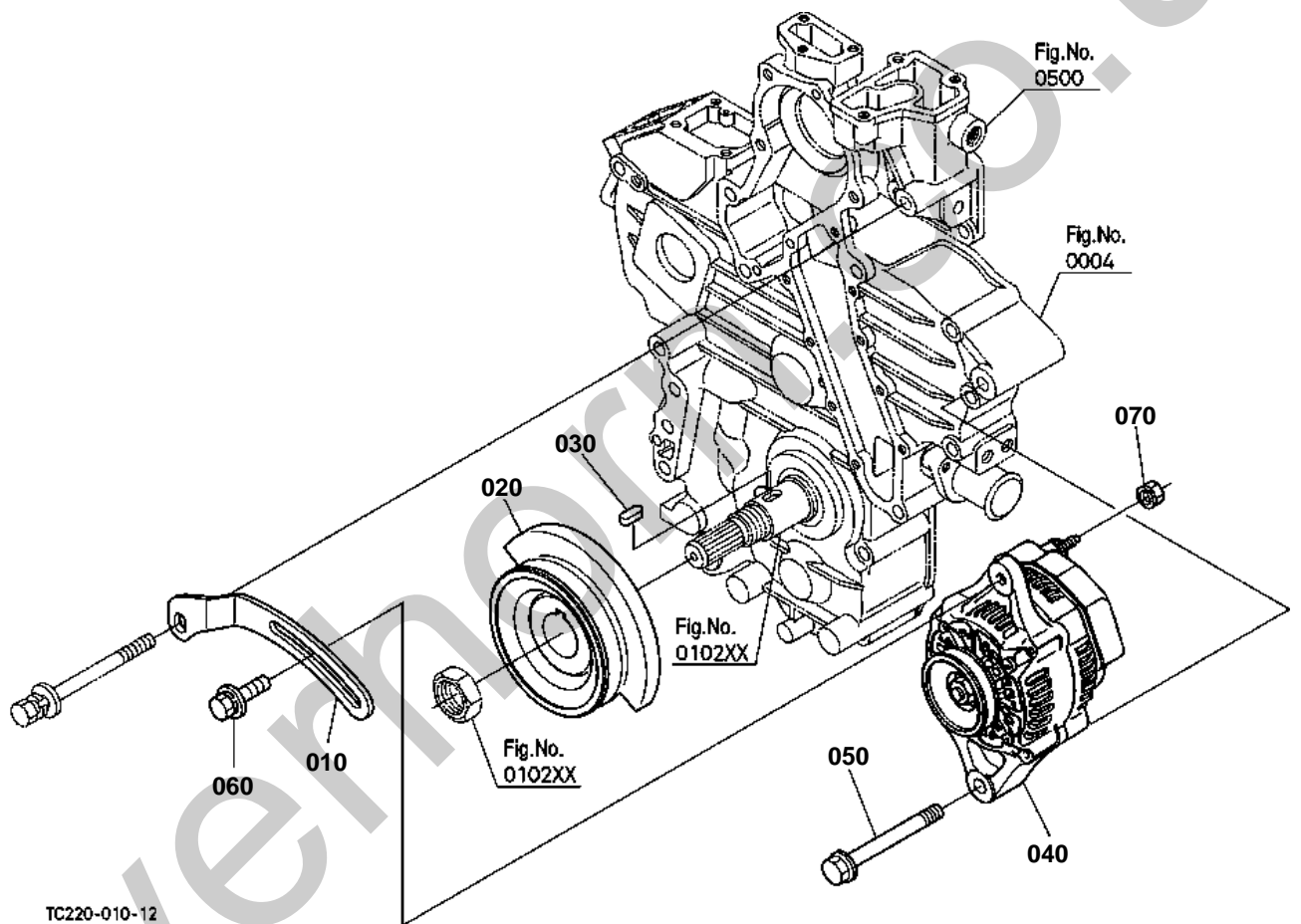

TC220-010-12



# ALTERNATOR

↔ Interchangeable; ≠ not interchangeable; ← new for old; → old for new

REF.No	Part No.	Description	Q'ty	S.No.	I/C	REMARKS	Weight (kgf)	Weight (lb)
010	1A033-64420	STAY DYNAMO	1				0.135	0.297
020	1A051-74280	PULLEY FAN DRIVE	1				1.39	3.058
030	05712-00720	KEY FEATHER	1				0.008	0.0176
040	T1060-15680	ASSY ALTERNATOR	1	<=52427			0	0
040	T1060-15682	ASSY ALTERNATOR	1	>=52428	-		3.05	6.71
050	01754-51070	BOLT FLANGE	1				0.01	0.022
060	01127-50830	BOLT	1				0.023	0.0506
070	12264-92020	NUT SPRING WASHER M	1				0.05	0.11

ALTERNATOR [COMPONENT PARTS]

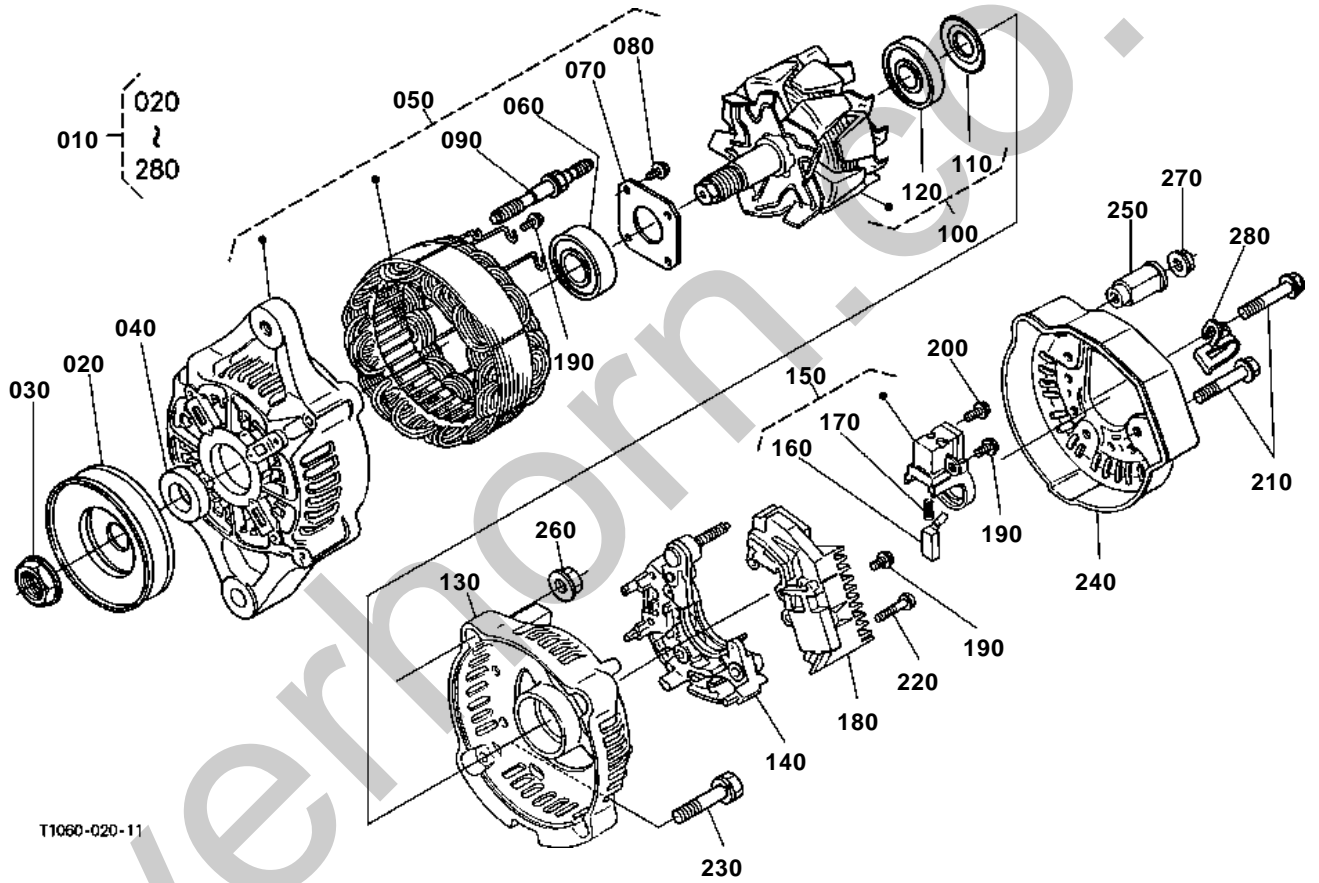



# ALTERNATOR [COMPONENT PARTS]

↔ Interchangeable; ≠ not interchangeable; ← new for old; → old for new

REF.No	Part No.	Description	Q'ty	S.No.	I/C	REMARKS	Weight (kgf)	Weight (lb)
010	T1060-15680	ASSY ALTERNATOR	1	<=52427			0	0
010	T1060-15682	ASSY ALTERNATOR	1	>=52428	-		3.05	6.71
020	16427-64110	PULLEY ALTERNATOR	1				0.2	0.44
030	15881-92010	NUT	1				0.02	0.044
040	15881-64150	COLLAR	1				0.004	0.0088
050	66436-64020	ASSY FRAME DRIVE END	1				1.11	2.442
060	16652-64780	BEARING BALL	1				0.05	0.11
070	15881-64710	PLATE RETAINER	1				0.01	0.022
080	15881-93010	SCREW ROUND HEAD	4				0.003	0.0066
090	15881-64260	BOLT THROUGH	2				0.01	0.022
100	66436-64040	ROTOR	1				1.2	2.64
110	15881-64800	COVER BEARING	1				0.001	0.0022
120	16652-64770	BEARING BALL	1				0.045	0.099
130	16241-64060	FRAME END	1				0.2	0.44
140	16231-64850	ASSY RECTIFIER	1				0.18	0.396
150	16652-64310	HOLDER BRUSH	1				0.025	0.055
160	15881-64090	BRUSH	2				0.002	0.0044
170	15881-64330	SPRING BRUSH	2				0.002	0.0044
180	66436-64600	ASSY REGULATOR	1	<=52427			0	0
180	1K531-64602	ASSY REGULATOR	1	>=52428	-		0.08	0.176
190	15881-93030	SCREW ROUND HEAD	6				0.003	0.0066
200	15881-93040	SCREW ROUND HEAD	1				0.003	0.0066
210	15881-91040	BOLT	3				0.005	0.011
220	15881-93020	SCREW ROUND HEAD	2				0.005	0.011
230	15881-91050	BOLT	2				0.01	0.022
240	16231-64230	COVER END	1				0.035	0.077
250	16241-64900	BUSH INSULATION	1				0.007	0.0154
260	15881-92020	NUT	2				0.02	0.044
270	14182-92030	NUT	1				0.003	0.0066
280	17369-67570	CLAMP CORD	1				0.001	0.0022



STARTER

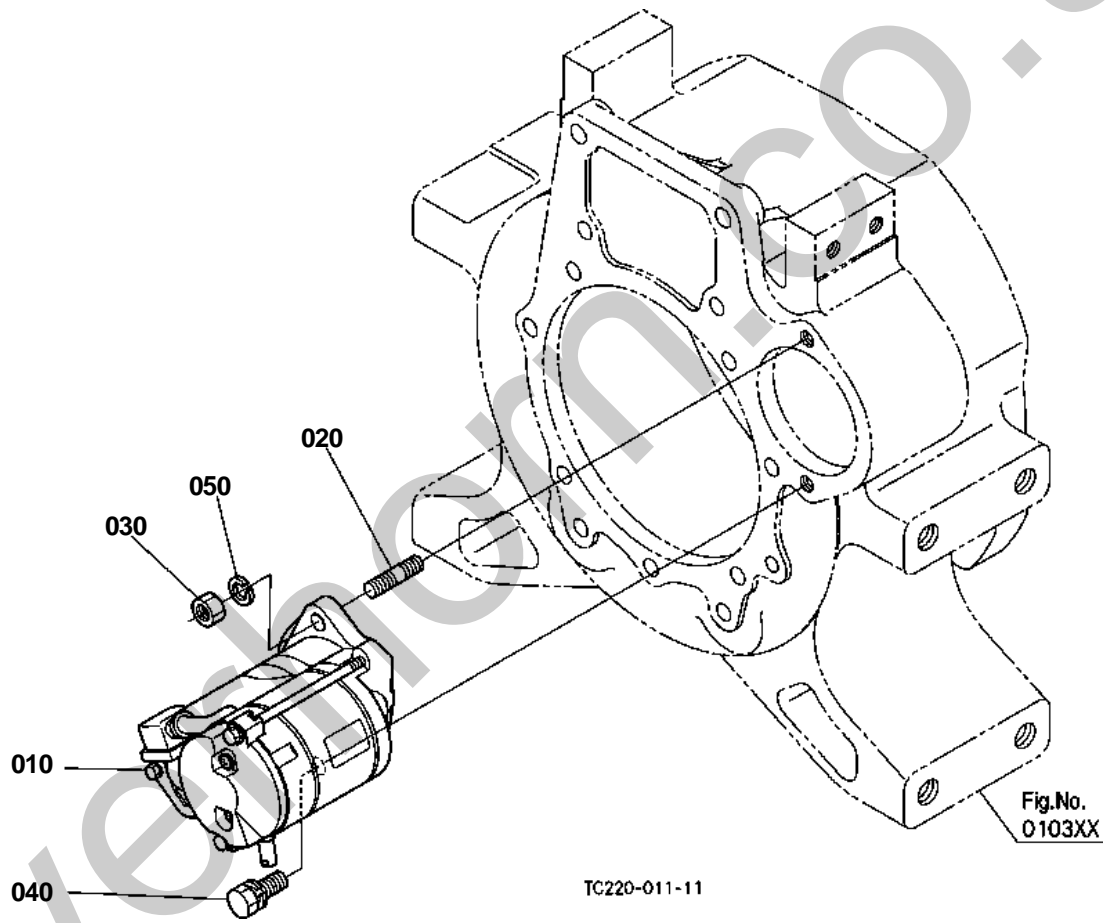



STARTER

↔ Interchangeable; ≠ not interchangeable; ← new for old; → old for new

REF.No	Part No.	Description	Q'ty	S.No.	I/C	REMARKS	Weight (kgf)	Weight (lb)
010	34070-16800	ASSY STARTER	1				3.4	7.48
020	01517-61030	STUD	1				0.021	0.0462
030	02176-50100	NUT	1				0.005	0.011
040	01133-51030	BOLT	1				0.025	0.055
050	04512-60100	WASHER SPRING	1				0.002	0.0044

STARTER [COMPONENT PARTS]

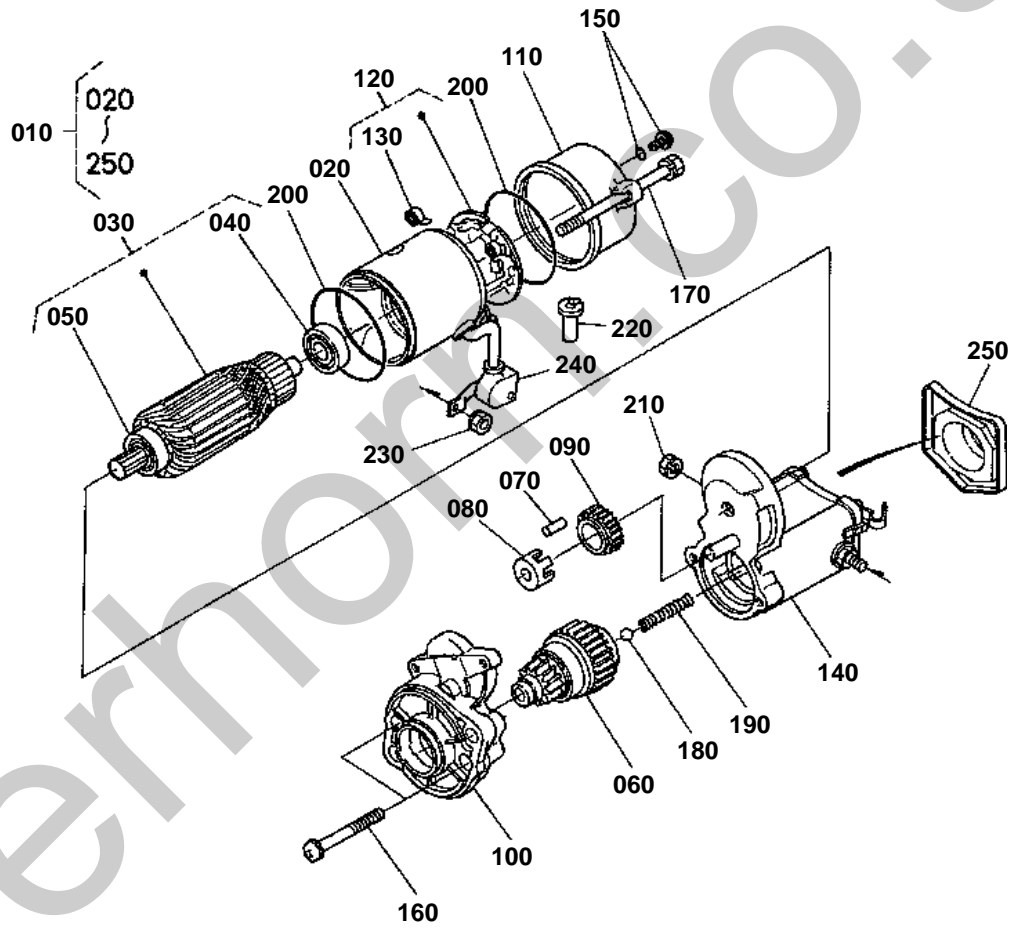

34070-008-15



# STARTER [COMPONENT PARTS]

↔ Interchangeable; ≠ not interchangeable; ← new for old; → old for new

REF.No	Part No.	Description	Q'ty	S.No.	I/C	REMARKS	Weight (kgf)	Weight (lb)
010	34070-16800	ASSY STARTER	1				3.4	7.48
020	11460-63080	YOKE	1				0.8	1.76
030	11460-63070	ARMATURE	1				0.05	0.11
040	11460-63530	BEARING	1				0.02	0.044
050	11460-63500	BEARING	1				0.03	0.066
060	34070-16810	ASSY CLUTCH	1				0.565	1.243
070	19212-63100	ROLLER	5				0.002	0.0044
080	11460-63110	RETAINER	1				0.01	0.022
090	11460-63270	GEAR	1				0.04	0.088
100	34070-16830	ASSY HOUSING	1				0.405	0.891
110	34070-16840	ASSY FRAME END	1				0.1	0.22
120	11470-63380	ASSY HOLDER BRUSH	1				0.3	0.66
130	11460-63390	SPRING BRUSH	4				0.01	0.022
140	34070-16850	ASSY SWITCH MAGNETIC	1				0.955	2.101
150	15511-63760	ASSY BOLT	2				0.005	0.011
160	11460-93310	BOLT	2				0.01	0.022
170	11460-63320	BOLT THROUGH	2				0.02	0.044
180	19212-97130	BALL	1				0.003	0.0066
190	11460-63120	SPRING	1				0.01	0.022
200	15511-96660	O RING	2				0.005	0.011
210	13963-92010	NUT HEXAGON	1				0.005	0.011
220	16285-63570	PIPE DRAIN	1				0.005	0.011
230	16285-92010	NUT HEXAGON	1				0.005	0.011
240	11173-63130	COVER TERMINAL	1				0.007	0.0154
250	16285-98050	ASSY COVER	1				0.048	0.1056

BATTERY [EXCEPT HST TYPE]

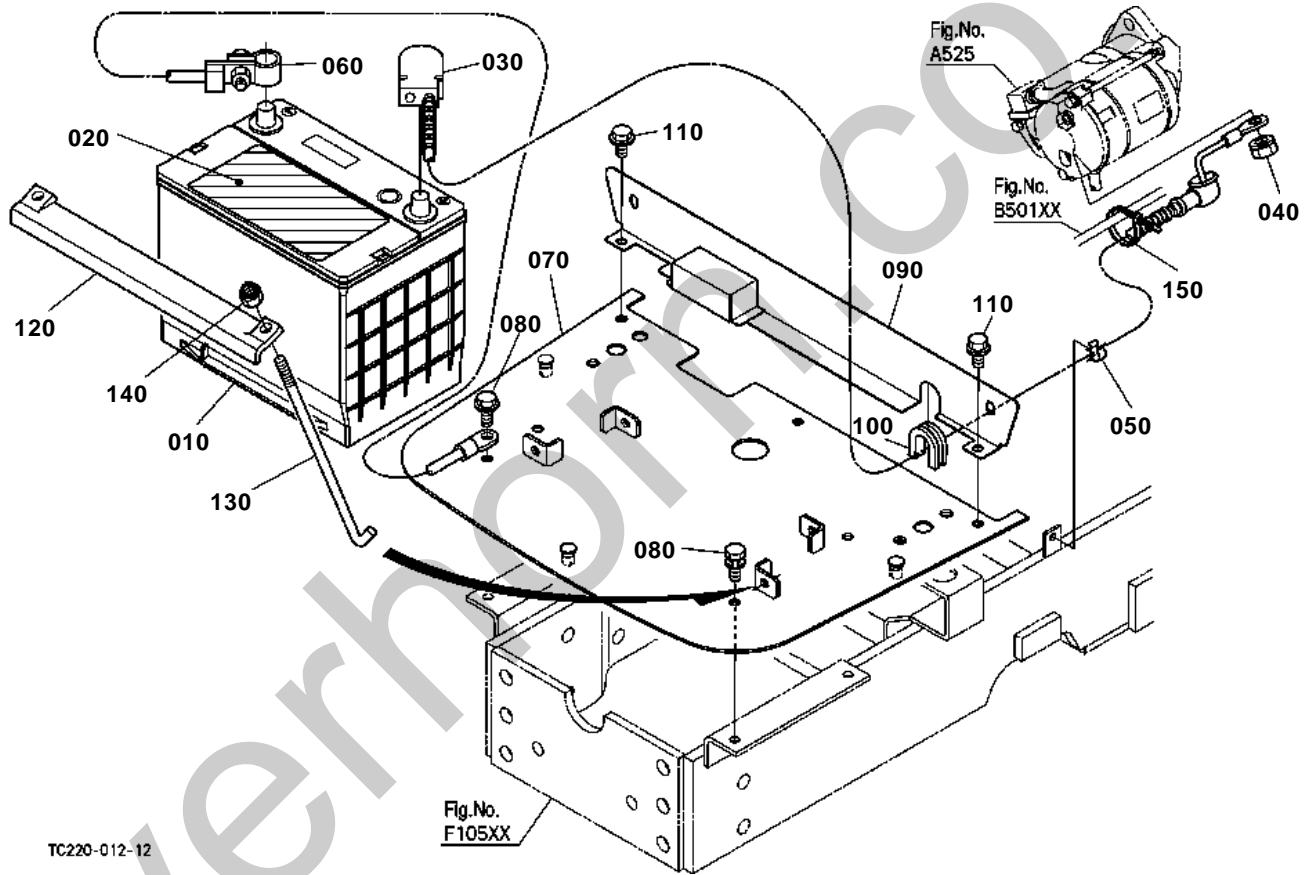

TC220-012-12

Fig.No.  
F105XX

Fig.No.  
A525

Fig.No.  
B501XX

# OLD PARTS

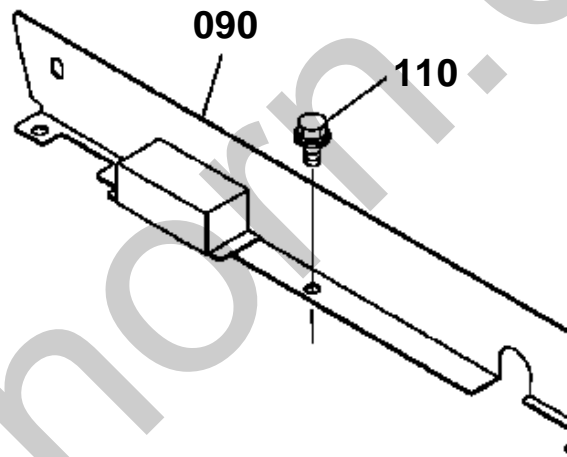
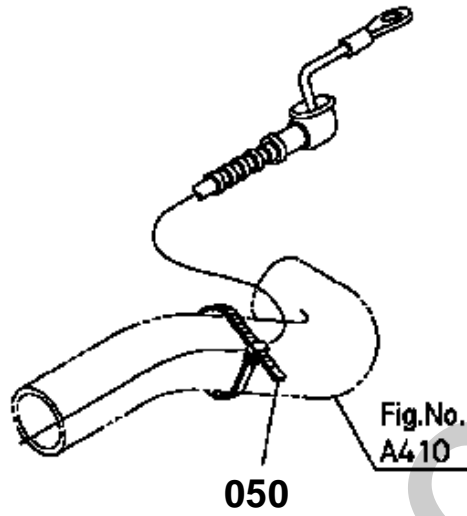

TC220-801-11

**BATTERY [EXCEPT HST TYPE]**

↔ Interchangeable; ≠ not interchangeable; ← new for old; → old for new

REF.No	Part No.	Description	Q'ty	S.No.	I/C	REMARKS	Weight (kgf)	Weight (lb)
010	99999-99999	BATTERY	1			75D26R	0	0
020	TD020-30122	LABEL BATTERY	1			ENGLISH	0.004	0.0088
030	TC220-30120	CORD BATTERY	1				0.32	0.704
040	16429-92010	NUT	1				0.007	0.0154
050	55311-41260	BAND CORD	1	<=52320			0.007	0.0154
050	T1060-30140	CLAMP	1	>=52321	1		0.002	0.0044
060	T1060-30130	CORD EARTH	1				0.08	0.176
070	TC220-45712	SUPPORT BATTERY	1				4.1	9.02
080	01123-50820	BOLT	4				0.011	0.0242
090	TC220-45720	PLATE	1	<=52580			0.37	0.814
090	TC220-45723	PLATE	1	>=52581	1		0.37	0.814
100	30430-82770	CUSHION	1				0.005	0.011
110	01754-50812	BOLT FLANGE	3	<=52580			0.01	0.022
110	01754-50812	BOLT FLANGE	2	>=52581			0.01	0.022
120	T1060-40110	RETAINER BATTERY	1				0.2	0.44
130	T0430-40120	BOLT HOOK	2				0.042	0.0924
140	02552-50060	NUT LOCK	2				0.002	0.0044
150	53581-64150	BAND CORD	1				0.002	0.0044

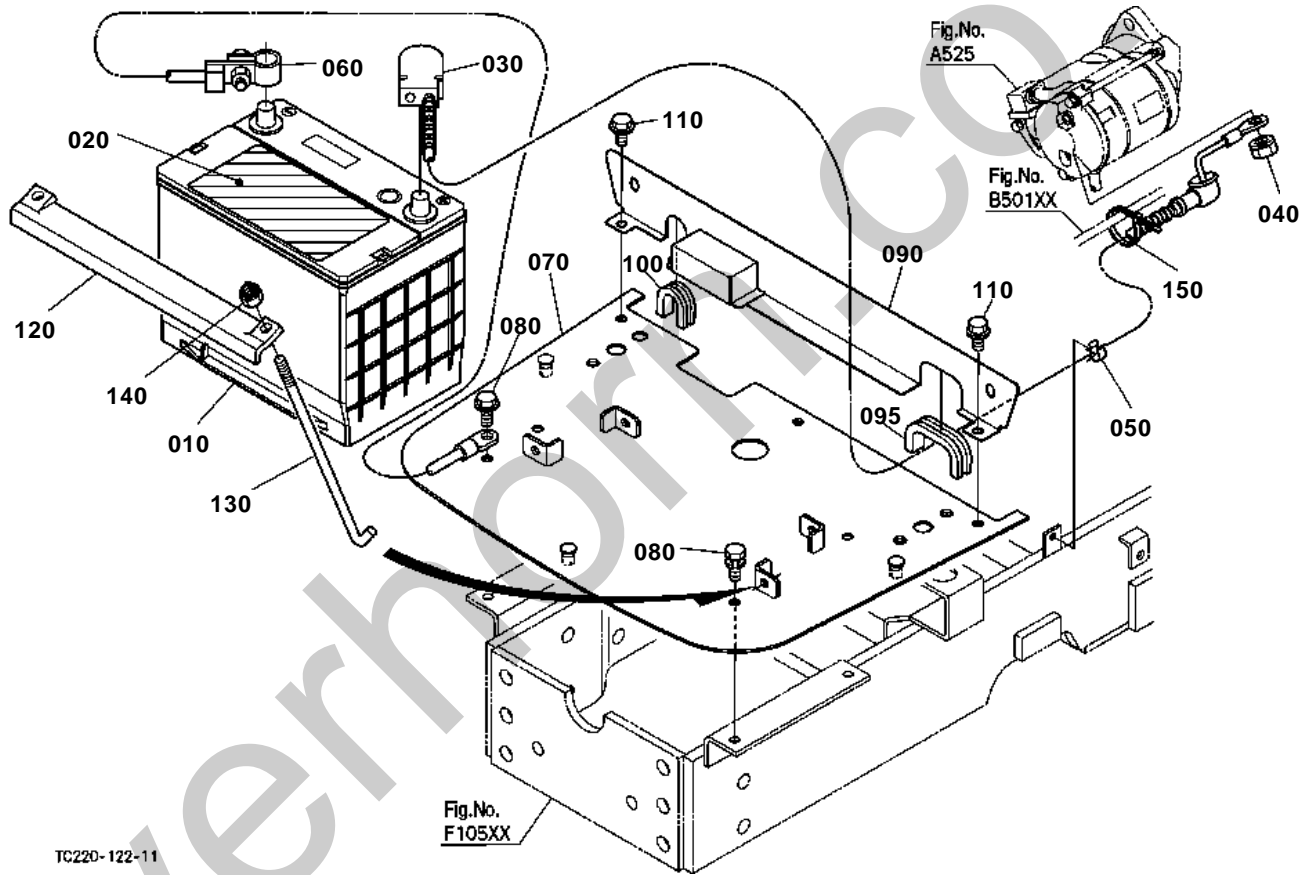

TC220-122-11



**BATTERY [HST TYPE]**

↔ Interchangeable; ≠ not interchangeable; ← new for old; → old for new

REF.No	Part No.	Description	Q'ty	S.No.	I/C	REMARKS	Weight (kgf)	Weight (lb)
010	99999-99999	BATTERY	1			75D26R	0	0
020	TD020-30122	LABEL BATTERY	1			ENGLISH	0.004	0.0088
030	TC220-30120	CORD BATTERY	1				0.32	0.704
040	16429-92010	NUT	1				0.007	0.0154
050	T1060-30140	CLAMP	1				0.002	0.0044
060	T1060-30130	CORD EARTH	1				0.08	0.176
070	TC220-45712	SUPPORT BATTERY	1				4.1	9.02
080	01123-50820	BOLT	4				0.011	0.0242
090	TC220-57212	PLATE RADIATOR	1				0	0
095	TC220-57220	CUSHION	1				0	0
100	30430-82770	CUSHION	1				0.005	0.011
110	01754-50812	BOLT FLANGE	2				0.01	0.022
120	T1060-40110	RETAINER BATTERY	1				0.2	0.44
130	T0430-40120	BOLT HOOK	2				0.042	0.0924
140	02552-50060	NUT LOCK	2				0.002	0.0044
150	53581-64150	BAND CORD	1				0.002	0.0044

SWITCH/RELAY

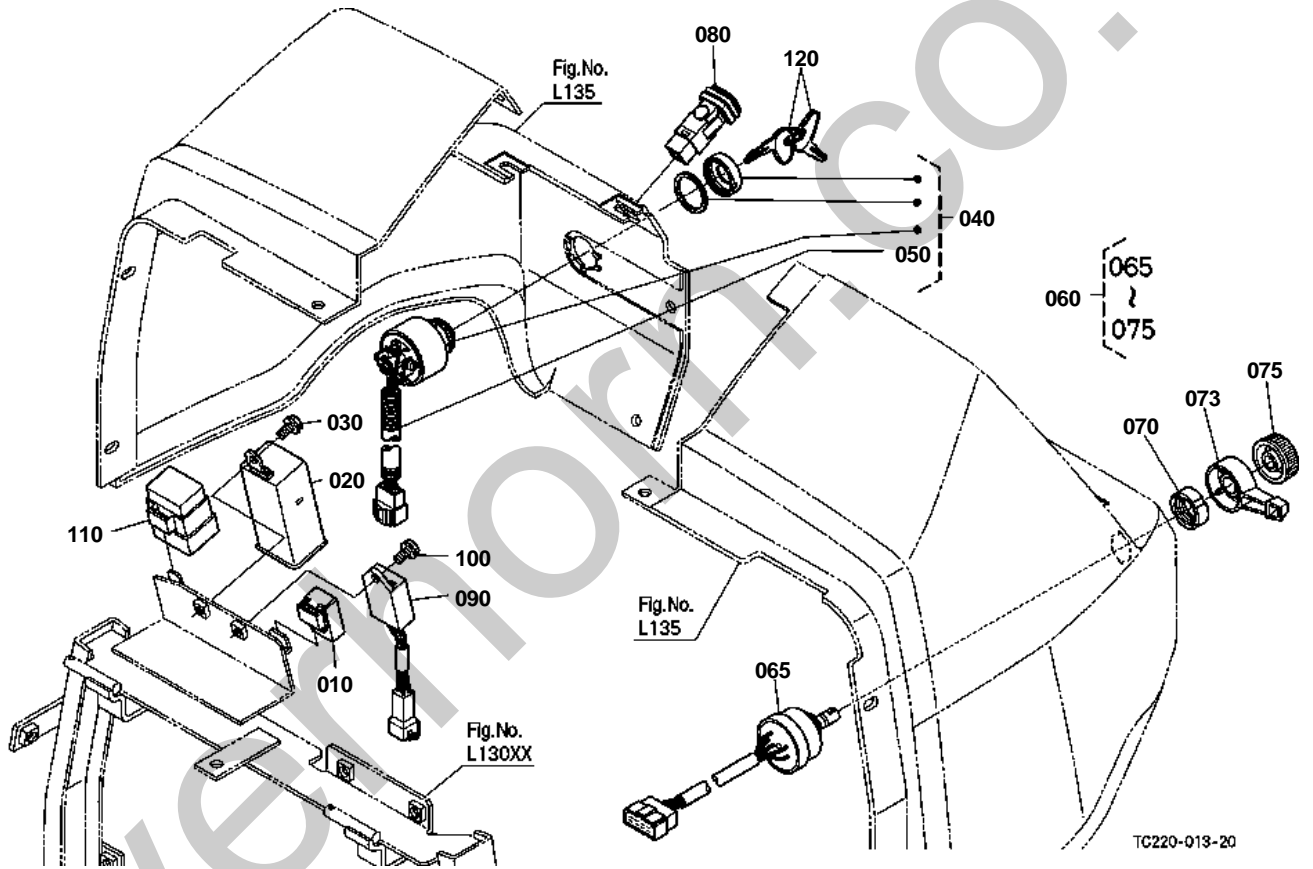

**SWITCH/RELAY**

↔ Interchangeable; ≠ not interchangeable; ← new for old; → old for new

REF.No	Part No.	Description	Q'ty	S.No.	I/C	REMARKS	Weight (kgf)	Weight (lb)
010	T1060-33720	RELAY STARTER	1				0.02	0.044
020	3F240-75430	UNIT FLASHER	1				0.06	0.132
030	01754-50616	BOLT FLANGE	1				0.006	0.0132
040	TC020-31820	SWITCH MAIN	1				0.242	0.5324
050	35080-31830	HARNESS MAIN SWITCH	1				0.02	0.044
060	67156-55210	SWITCH COMBINATION	1				0.095	0.209
065	67156-55260	ASSY BODY SWITCH	1				0.07	0.154
070	67156-55230	NUT RING	1				0.003	0.0066
073	67156-55240	LEVER FLASHER	1				0.004	0.0088
075	67156-55250	KNOB LIGHT	1				0.004	0.0088
080	TA140-30910	SWITCH HAZARD	1				0.115	0.253
090	TD060-30500	TIMER OPC	1				0.04	0.088
100	01754-50616	BOLT FLANGE	1				0.006	0.0132
110	T1060-33710	RELAY GLOW	1				0.07	0.154
120	35260-31852	ASSY KEY MAIN SWITCH	1				0.03	0.066

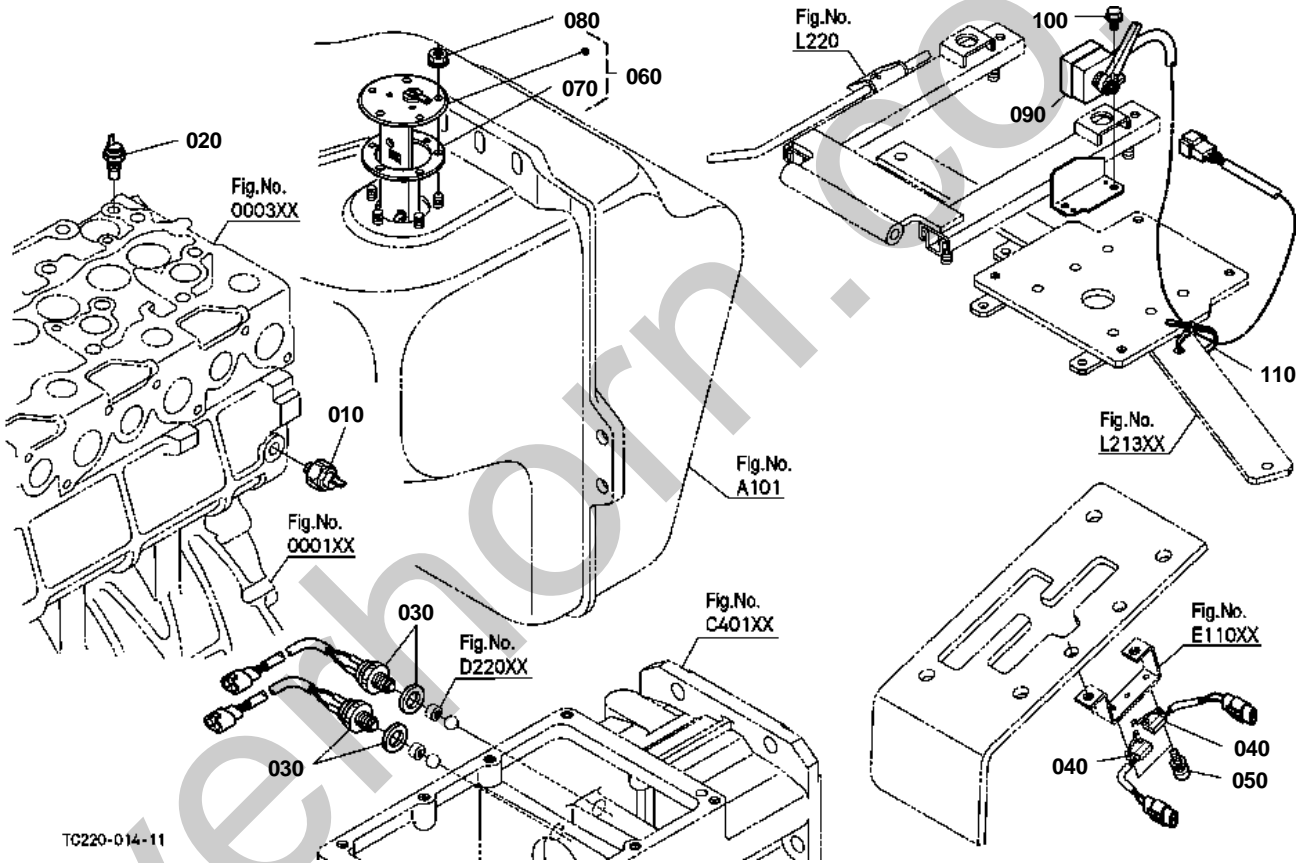

**SWITCH /SENSOR [EXCEPT HST TYPE]**

↔ Interchangeable; ≠ not interchangeable; ← new for old; → old for new

REF.No	Part No.	Description	Q'ty	S.No.	I/C	REMARKS	Weight (kgf)	Weight (lb)
010	15531-39010	SWITCH OIL	1				0.032	0.0704
020	32330-32830	SENSOR WATER TEMP.	1				0.01	0.022
030	T0430-32370	SWITCH POSITION	2				0.055	0.121
040	TC220-43900	SWITCH LEVER	2				0.005	0.011
050	03034-50312	SCREW WITH WASHER	2				0.012	0.0264
060	TC220-31200	SENSOR FUEL GAUGE	1				0.15	0.33
070	6A320-85812	GASKET GAUGE	1				0.005	0.011
080	02761-50050	NUT FLANGE	5				0.002	0.0044
090	TD060-47902	SWITCH SEAT	1				0.03	0.066
100	01754-50612	BOLT FLANGE	1				0.005	0.011
110	44366-68380	BAND CORD	1				0.01	0.022

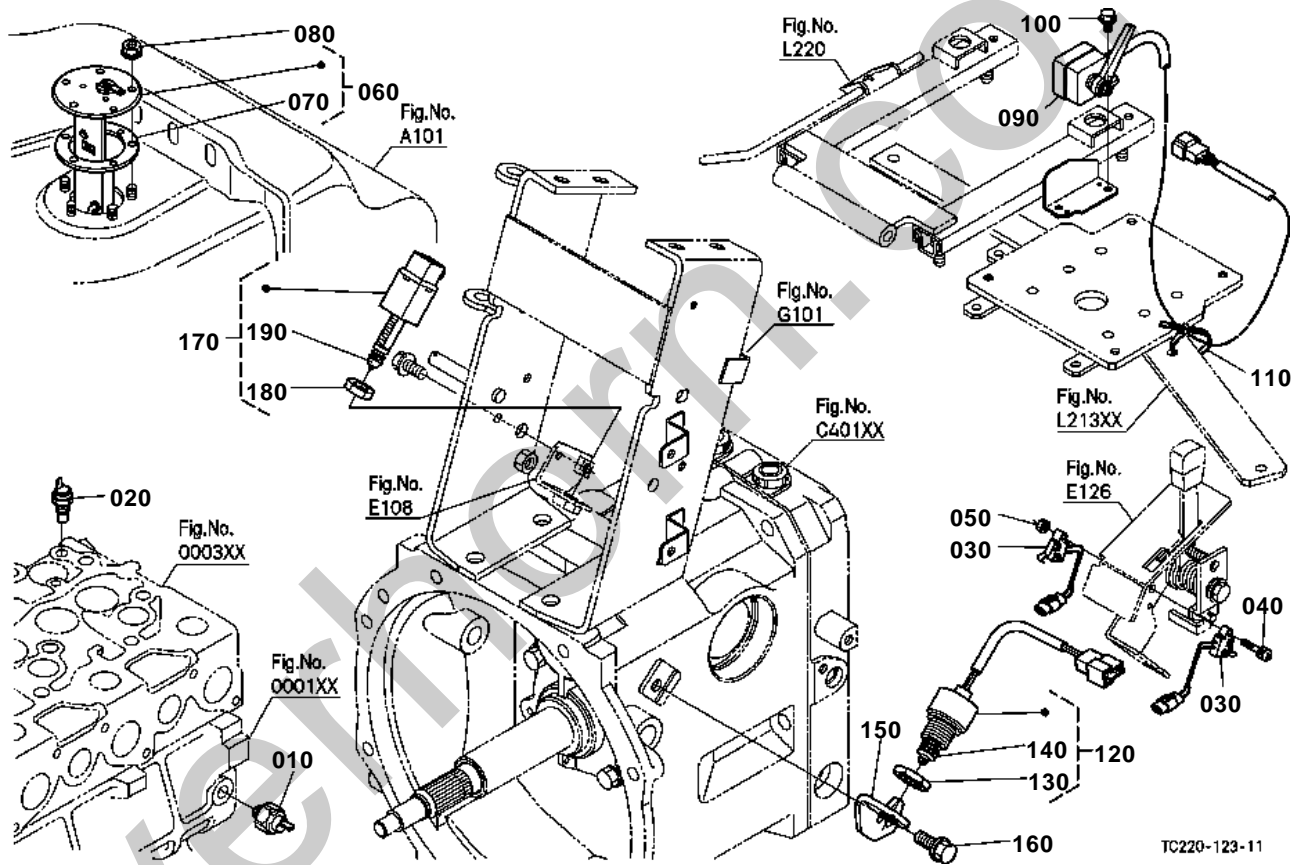

## OLD PARTS

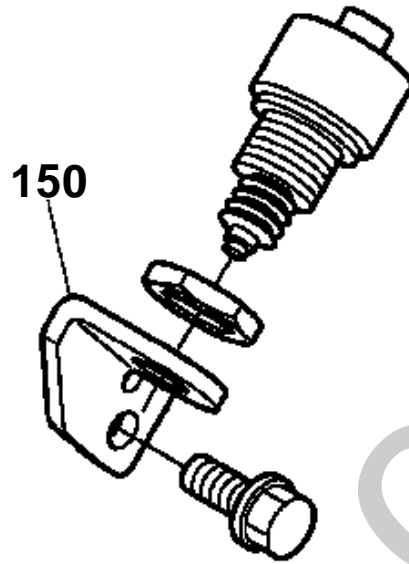

Silverhorn.CO.UK

TC220-851-10

**SWITCH/SENSOR [HST TYPE]**

↔ Interchangeable; ≠ not interchangeable; ← new for old; → old for new

REF.No	Part No.	Description	Q'ty	S.No.	I/C	REMARKS	Weight (kgf)	Weight (lb)
010	15531-39010	SWITCH OIL	1				0.032	0.0704
020	32330-32830	SENSOR WATER TEMP.	1				0.01	0.022
030	T1060-43900	SWITCH LEVER	2				0.01	0.022
040	03024-50425	SCREW WITH WASHER	1				0.003	0.0066
050	02054-50040	NUT	1				0.001	0.0022
060	TC220-31200	SENSOR FUEL GAUGE	1				0.15	0.33
070	6A320-85812	GASKET GAUGE	1				0.005	0.011
080	02761-50050	NUT FLANGE	5				0.002	0.0044
090	TD060-47902	SWITCH SEAT	1				0.03	0.066
100	01754-50612	BOLT FLANGE	1				0.005	0.011
110	44366-68380	BAND CORD	1				0.01	0.022
120	6A100-30860	ASSY SWITCH SAFETY	1				0.13	0.286
130	67111-55830	NUT SAFETY SWITCH	1				0.035	0.077
140	67111-55840	CAP SAFETY SWITCH	1				0.002	0.0044
150	TC220-51230	BRACKET SWITCH	1	<=57744			0	0
150	TC220-51233	BRACKET SWITCH	1	>=57745	1		0	0
160	01774-61020	BOLT FLANGE	1				0.022	0.0484
170	TD060-53900	SWITCH NEUTRAL	1				0.09	0.198
180	67111-55830	NUT SAFETY SWITCH	1				0.035	0.077
190	TD060-53910	COVER SWITCH	1				0.001	0.0022



PANEL BOARD

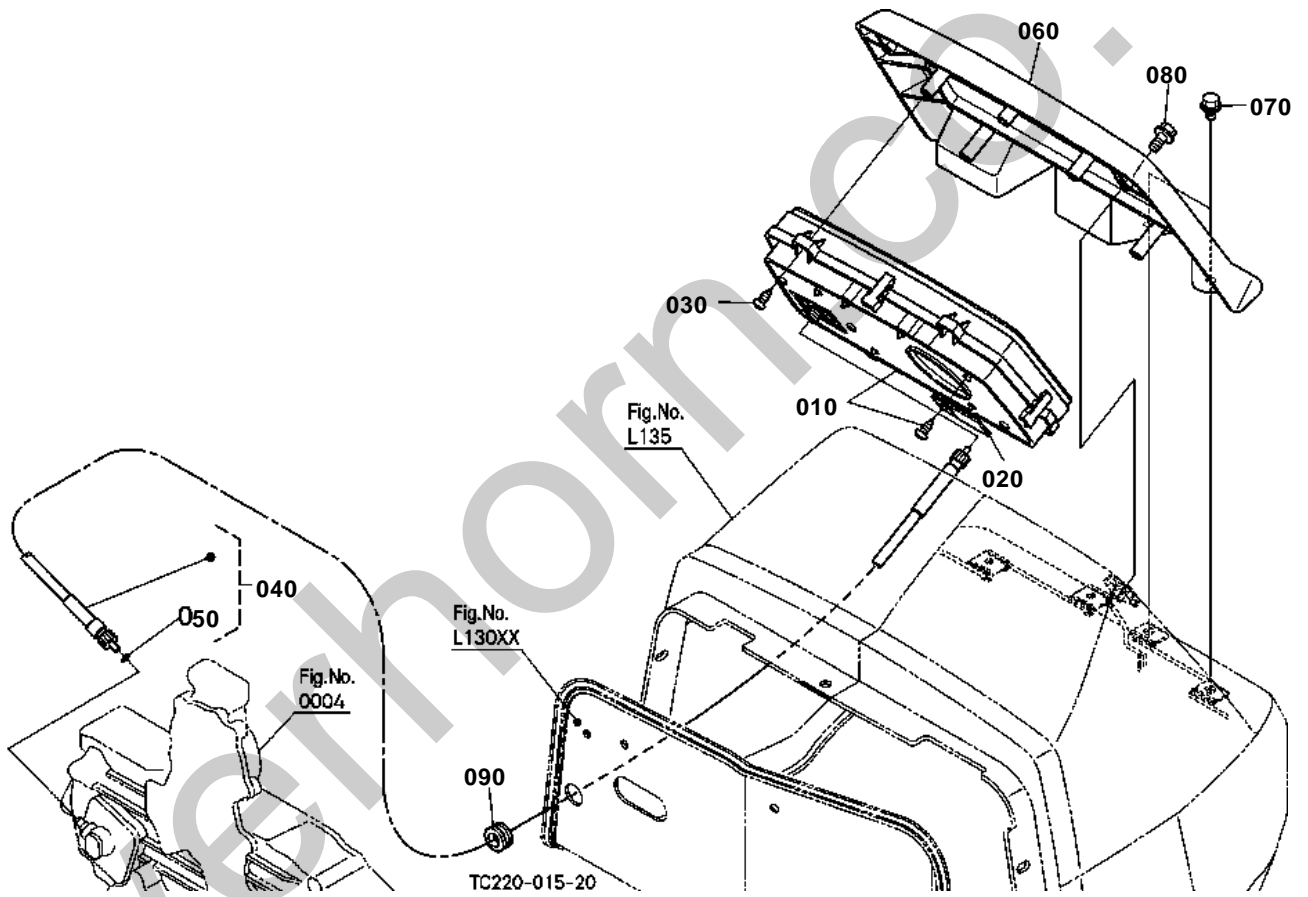

OLD PARTS

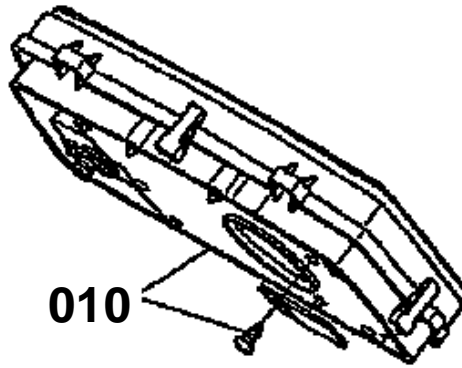

Silverhorn.CO.UK

TC220-829-10



PANEL BOARD

↔ Interchangeable; ≠ not interchangeable; ← new for old; → old for new

REF.No	Part No.	Description	Q'ty	S.No.	I/C	REMARKS	Weight (kgf)	Weight (lb)
010	TC020-30215	ASSY PANEL	1	<=52427			0	0
010	TC020-30216	ASSY PANEL	1	>=52428	-		0.8	1.76
020	15241-67580	CLAMP CORD	1				0.004	0.0088
030	03614-50620	SCREW TAPPING	4				0.003	0.0066
040	31341-34654	CABLE FLEXIBLE	1				0.22	0.484
050	04811-10080	O RING	1				0.001	0.0022
060	TC020-43020	COVER METER PANEL	1				0.4	0.88
070	31351-18790	BOLT FLANGE	4				0.007	0.0154
080	5H100-32900	BOLT FLANGE	2				0.01	0.022
090	37410-51760	GROMMET	1				0.003	0.0066

PANEL BOARD [COMPONENT PARTS]

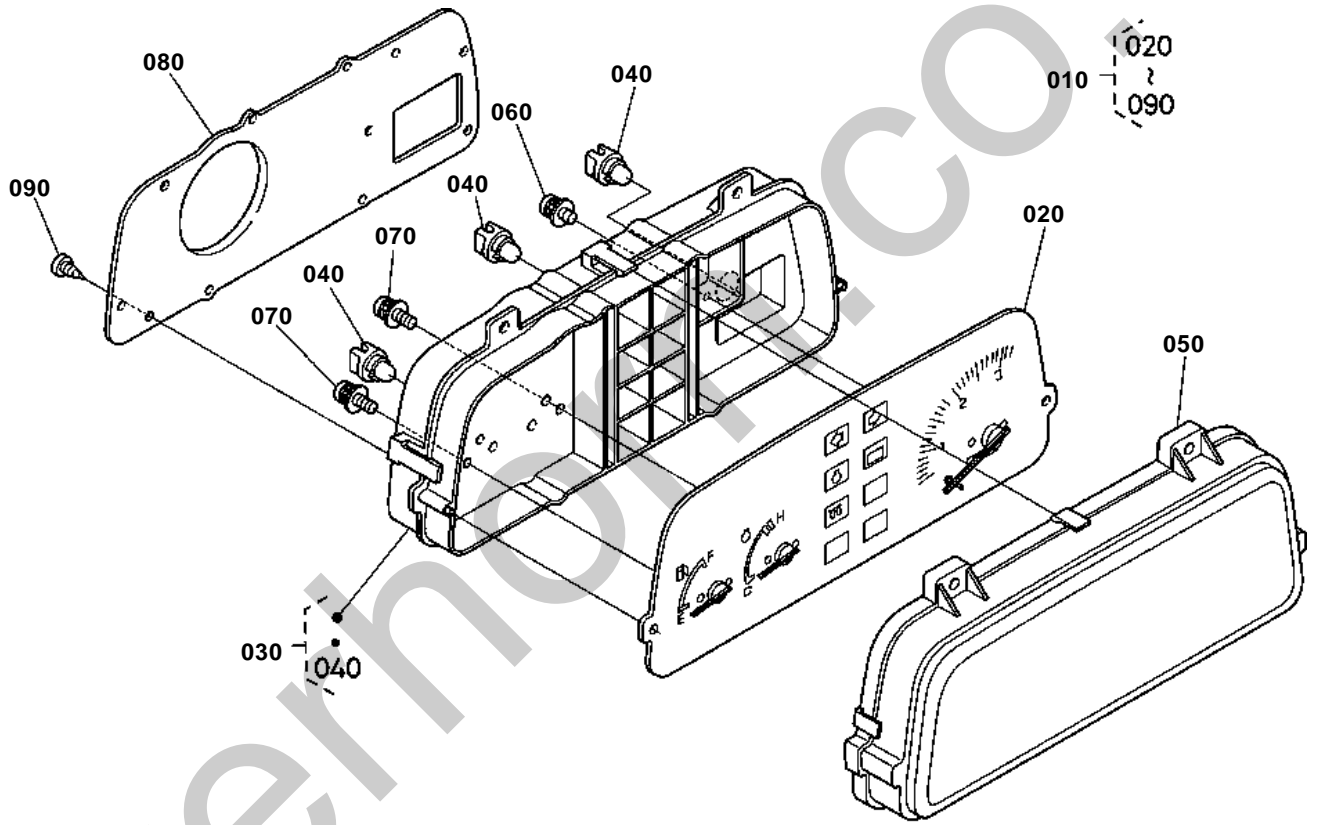

TC020-021-12

OLD PARTS

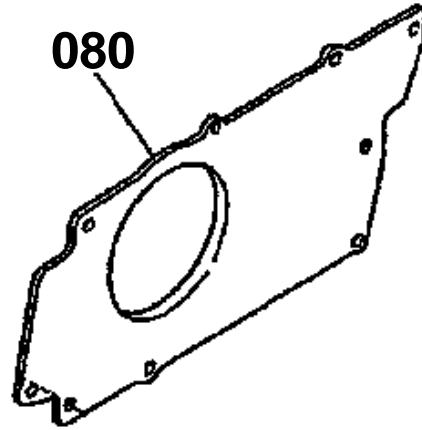

Silverhorn.CO.UK

TC220-B28-10



PANEL BOARD [COMPONENT PARTS]

↔ Interchangeable; ≠ not interchangeable; ← new for old; → old for new

REF.No	Part No.	Description	Q'ty	S.No.	I/C	REMARKS	Weight (kgf)	Weight (lb)
010	TC020-30215	ASSY PANEL	1	<=52427			0	0
010	TC020-30216	ASSY PANEL	1	>=52428	-		0.8	1.76
020	TC020-30223	COMP.METER	1				0.37	0.814
030	TC020-30250	ASSY CASE	1	<=52427			0.31	0.682
030	TC020-30252	ASSY CASE	1	>=52428	-		0.31	0.682
040	6C040-55140	ASSY BULB	7			1.7W	0.003	0.0066
050	TC020-30260	GLASS	1				0.175	0.385
060	6C040-55150	SCREW	2				0.002	0.0044
070	6C040-55160	SCREW	6				0.002	0.0044
080	TC020-30270	COVER	1	<=52427			0.075	0.165
080	TC020-30272	COVER	1	>=52428	-		0.075	0.165
090	6C040-55180	SCREW	3	<=52427			0.003	0.0066
090	6C040-55180	SCREW	5	>=52428			0.003	0.0066

HEAD LIGHT [OLD TYPE]

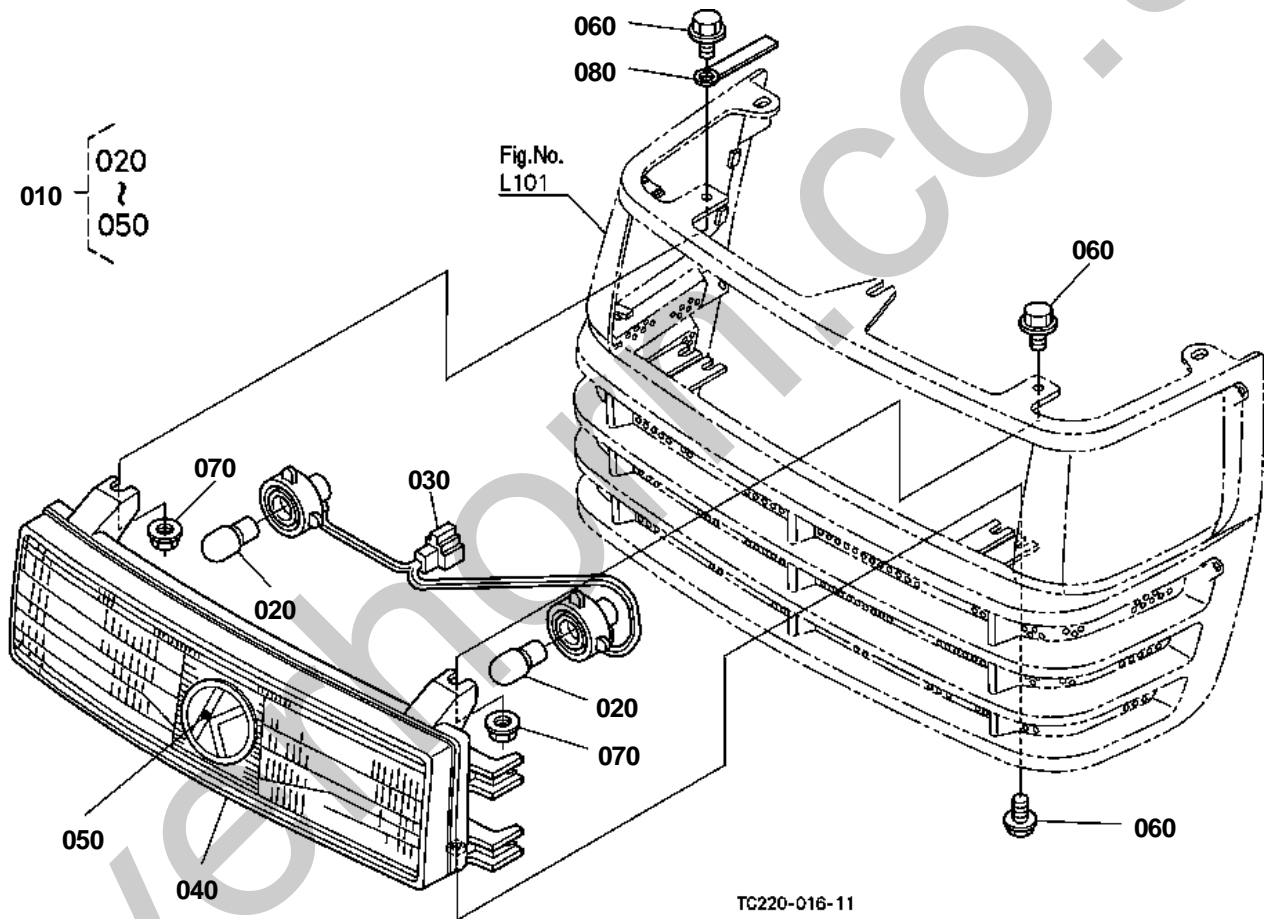

TC220-016-11

**HEAD LIGHT [OLD TYPE]**

S.No.;&lt;=52580

↔ Interchangeable; ≠ not interchangeable; ← new for old; → old for new

REF.No	Part No.	Description	Q'ty	S.No.	I/C	REMARKS	Weight (kgf)	Weight (lb)
010	T0421-30010	ASSY LIGHT HEAD	1				0.69	1.518
020	34070-99010	BULB	2			25W	0.02	0.044
030	T0430-99090	ASSY WIRE HARNESS	1				0.05	0.11
040	TA140-99100	UNIT LAMP	1				0.6	1.32
050	TA140-49500	MARK SYMBOL	1				0.013	0.0286
060	01754-50612	BOLT FLANGE	4				0.005	0.011
070	02751-50060	NUT FLANGE	2				0.005	0.011
080	15241-67580	CLAMP CORD	1				0.004	0.0088



HEAD LIGHT [NEW TYPE]

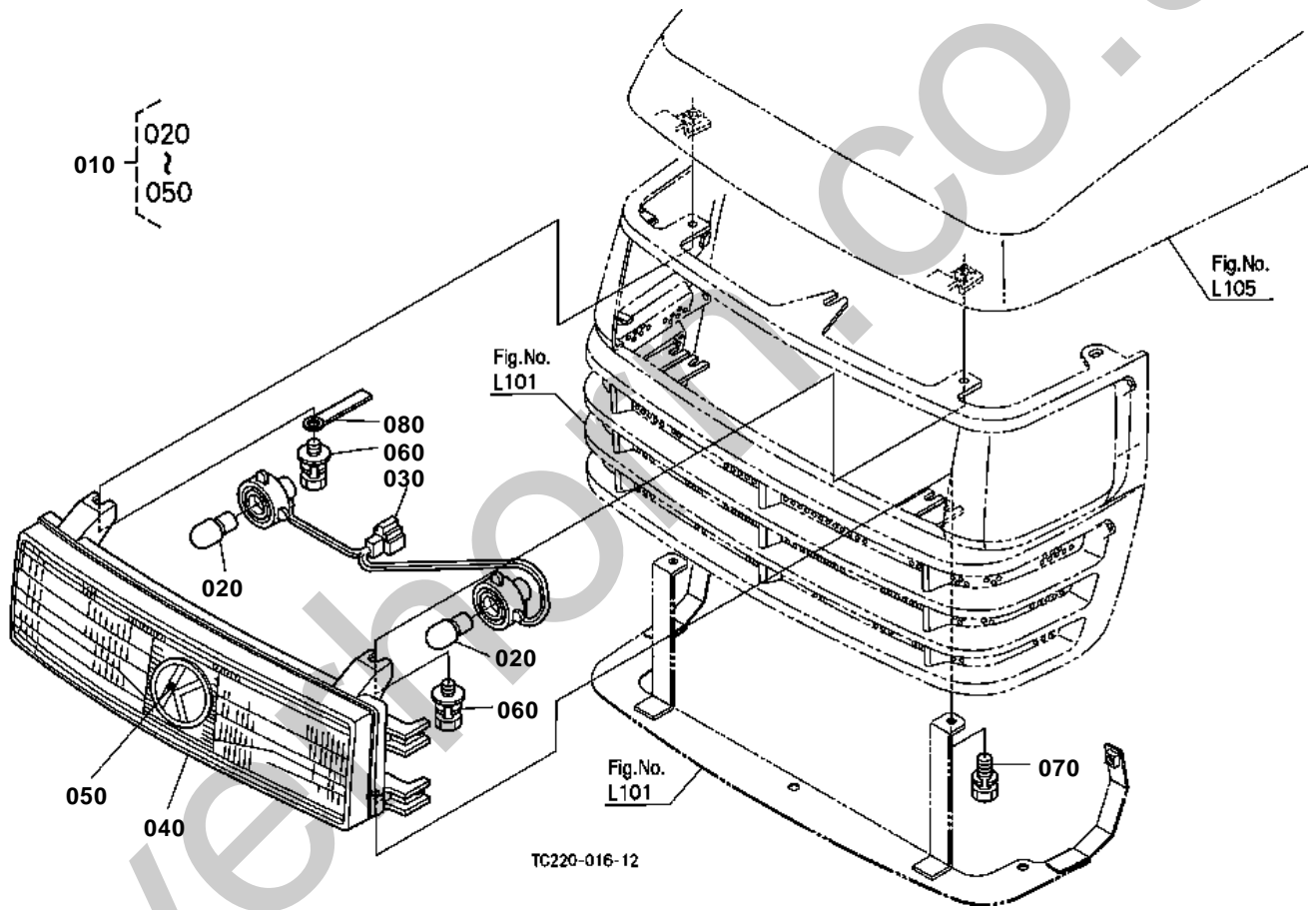

**HEAD LIGHT [NEW TYPE]**

S.No.;&gt;=52581

↔ Interchangeable; ≠ not interchangeable; ← new for old; → old for new

REF.No	Part No.	Description	Q'ty	S.No.	I/C	REMARKS	Weight (kgf)	Weight (lb)
010	T0421-30010	ASSY LIGHT HEAD	1				0.69	1.518
020	34070-99010	BULB	2			25W	0.02	0.044
030	T0430-99090	ASSY WIRE HARNESS	1				0.05	0.11
040	TA140-99100	UNIT LAMP	1				0.6	1.32
050	TA140-49500	MARK SYMBOL	1				0.013	0.0286
060	01025-50616	BOLT	2				0.005	0.011
070	01023-50616	BOLT	2				0.005	0.011
080	15241-67580	CLAMP CORD	1				0.004	0.0088

HAZARD LIGHT

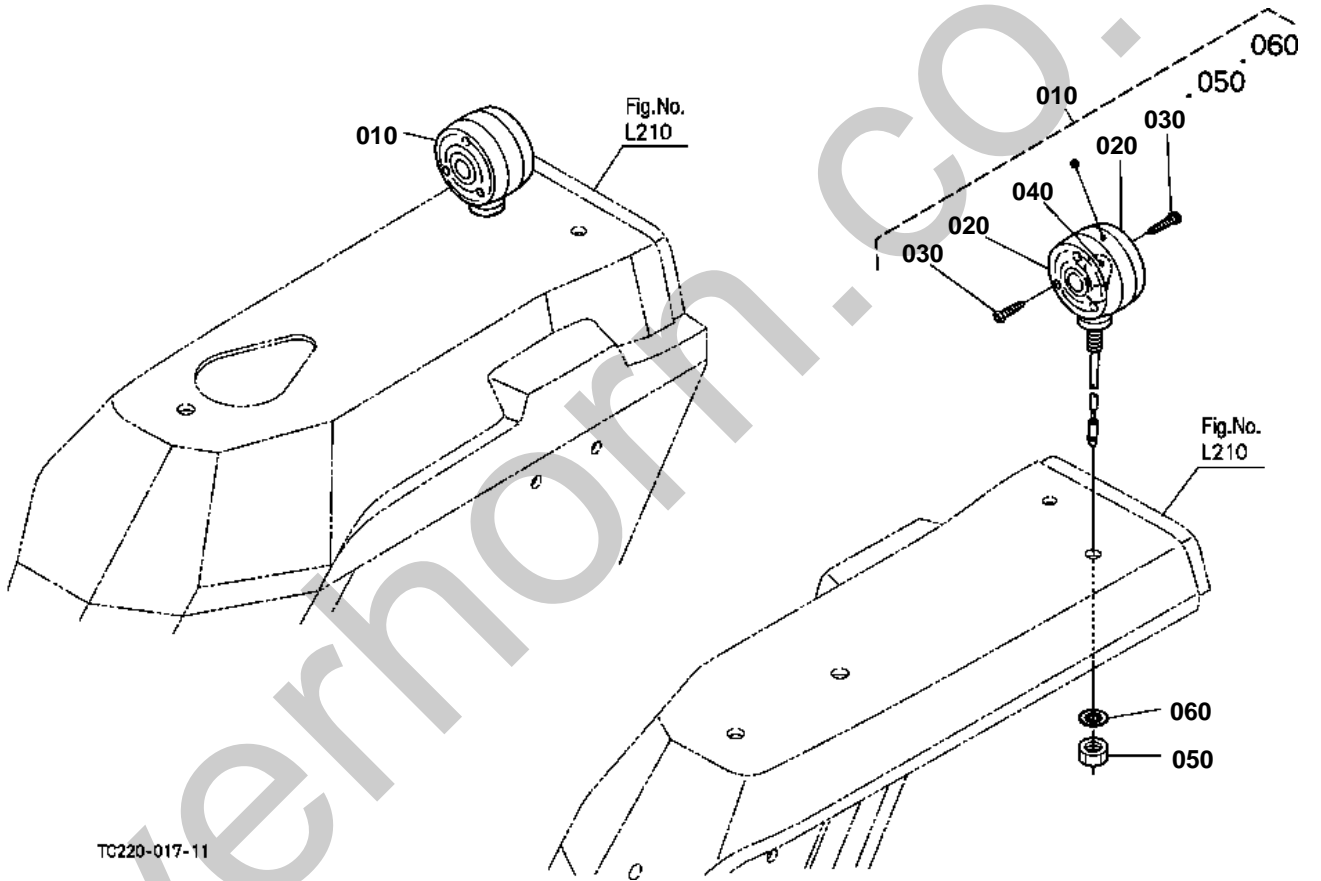

TC220-017-11



# HAZARD LIGHT

↔ Interchangeable; ≠ not interchangeable; ← new for old; → old for new

REF.No	Part No.	Description	Q'ty	S.No.	I/C	REMARKS	Weight (kgf)	Weight (lb)
010	32530-33610	ASSY LIGHT HAZARD	2				0.38	0.836
020	32530-91510	LENS HAZARD LIGHT	4				0.085	0.187
030	32530-91520	SCREW TAPPING	12				0.001	0.0022
040	32530-91530	BULB LIGHT	2			27W	0.02	0.044
050	02114-50100	NUT	2				0.005	0.011
060	04411-50100	WASHER TOOTHED	2				0.001	0.0022

REAR LAMP

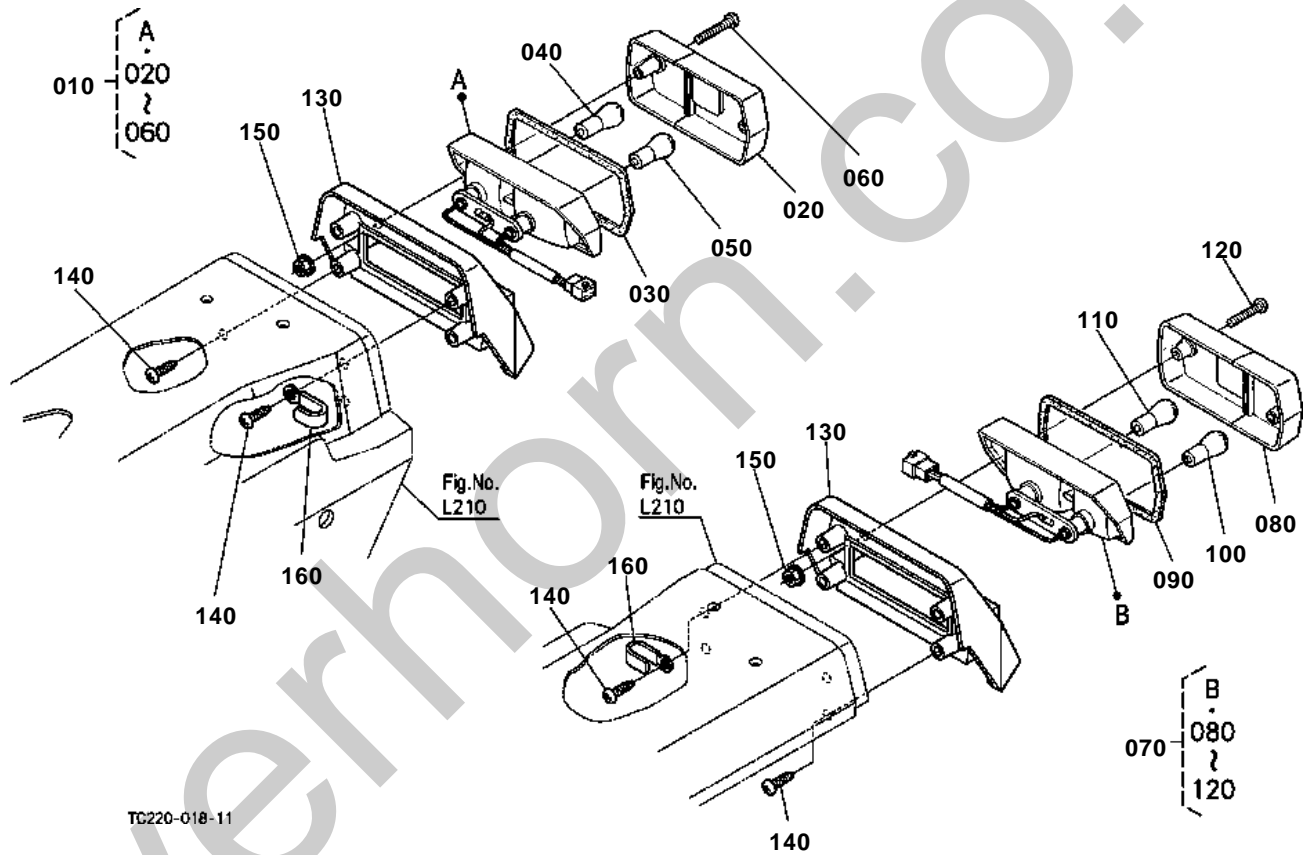



REAR LAMP

↔ Interchangeable; ≠ not interchangeable; ← new for old; → old for new

REF.No	Part No.	Description	Q'ty	S.No.	I/C	REMARKS	Weight (kgf)	Weight (lb)
010	T1150-34302	ASSY LIGHT COMBI.RH	1				0.31	0.682
020	31301-34340	LENS	1				0.105	0.231
030	31391-34350	GASKET	1				0.002	0.0044
040	31391-34360	BULB	1			23W	0.018	0.0396
050	31301-34370	BULB	1			23/8W	0.02	0.044
060	T1150-34380	SCREW	2				0.006	0.0132
070	T1150-34312	ASSY LIGHT COMBI.LH	1				0.31	0.682
080	31301-34340	LENS	1				0.105	0.231
090	31391-34350	GASKET	1				0.002	0.0044
100	31391-34360	BULB	1			23W	0.018	0.0396
110	31301-34370	BULB	1			23/8W	0.02	0.044
120	T1150-34380	SCREW	2				0.006	0.0132
130	34040-68960	HOLDER	2				0.23	0.506
140	03614-50614	SCREW TAPPING	8				0.005	0.011
150	02761-50050	NUT FLANGE	4				0.002	0.0044
160	15272-67590	CLAMP CORD	2			<=52427	0.004	0.0088
160	15272-67580	CLAMP CORD	2			>=52428	0.021	0.0462

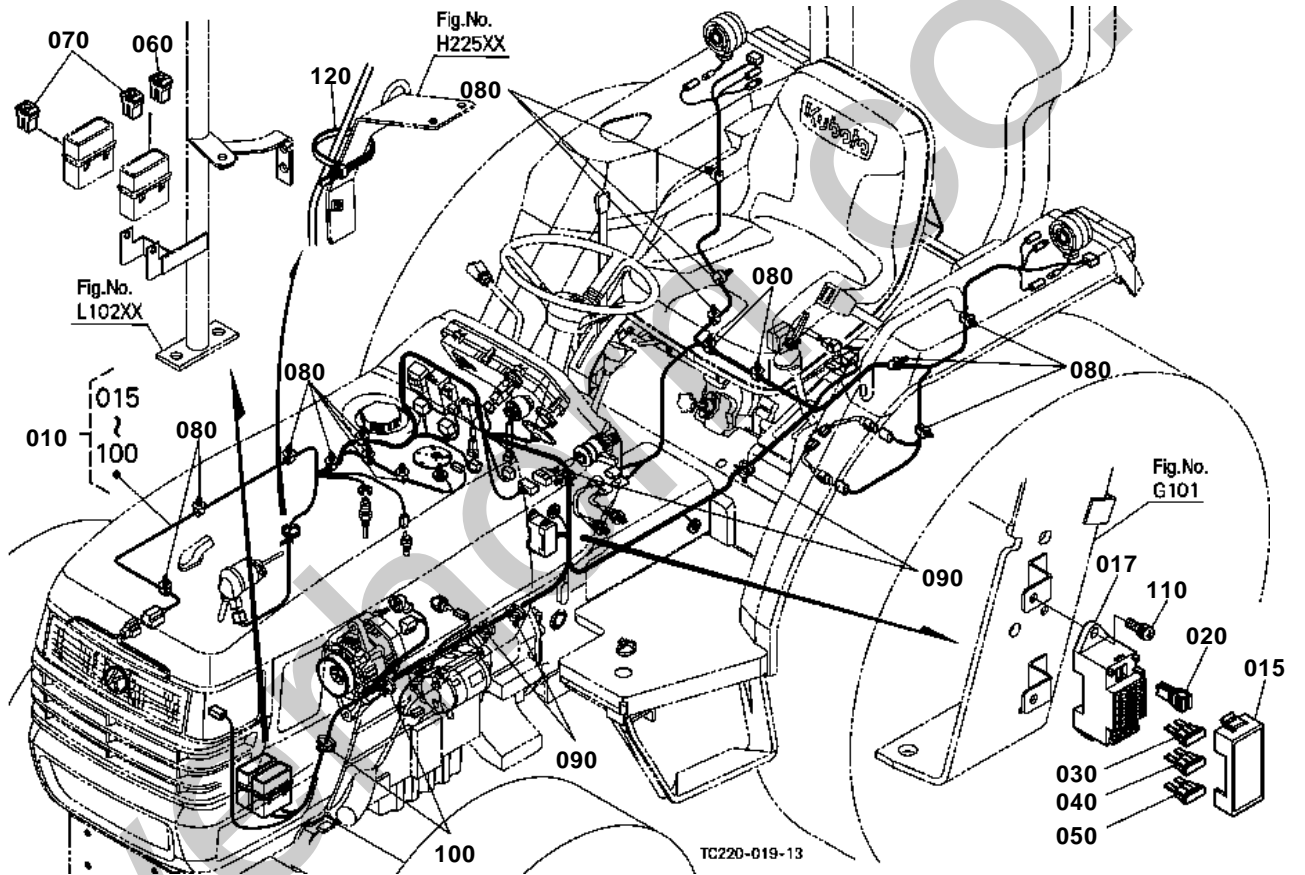

# OLD PARTS

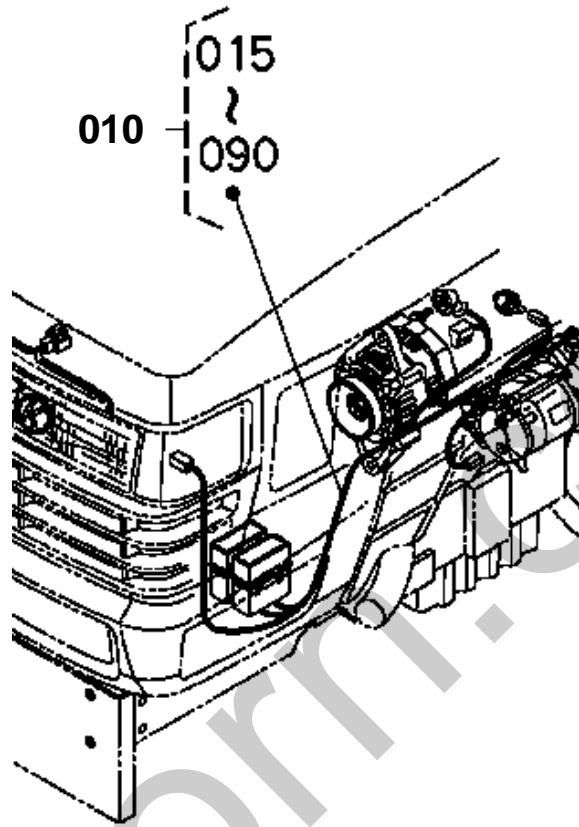

TC220-812-11



**ELECTRICAL WIRING [EXCEPT HST TYPE]**

↔ Interchangeable; ≠ not interchangeable; ← new for old; → old for new

REF.No	Part No.	Description	Q'ty	S.No.	I/C	REMARKS	Weight (kgf)	Weight (lb)
010	TC220-30310	WIRE HARNESS	1	<=50003			0	0
010	TC220-30312	WIRE HARNESS	1	>=50004	-		0	0
010	TC220-30313	WIRE HARNESS	1	>=52901	-		1.7	3.74
015	TC220-30410	COVER FUSE BOX	1				0	0
017	T1060-30420	CASE FUSE BOX	1				0	0
020	T1060-30490	PULLER FUSE	1				0.005	0.011
030	T1060-30430	FUSE	4			5A	0.005	0.011
040	T1060-30440	FUSE	3			10A	0.005	0.011
050	T1060-30450	FUSE	3			15A	0.005	0.011
060	T1060-30510	FUSE	1			30A	0.007	0.0154
070	T1060-30520	FUSE	2			40A	0.007	0.0154
080	T1060-30540	CLIP	15				0.01	0.022
090	RP421-54110	CLAMP	4				0.002	0.0044
100	T1060-30550	CLIP	2	>=50004			0.01	0.022
100	TD060-30570	CLIP	2		←		0.003	0.0066
110	31391-31140	SCREW	2				0.01	0.022
120	55311-41260	BAND CORD	1				0.007	0.0154

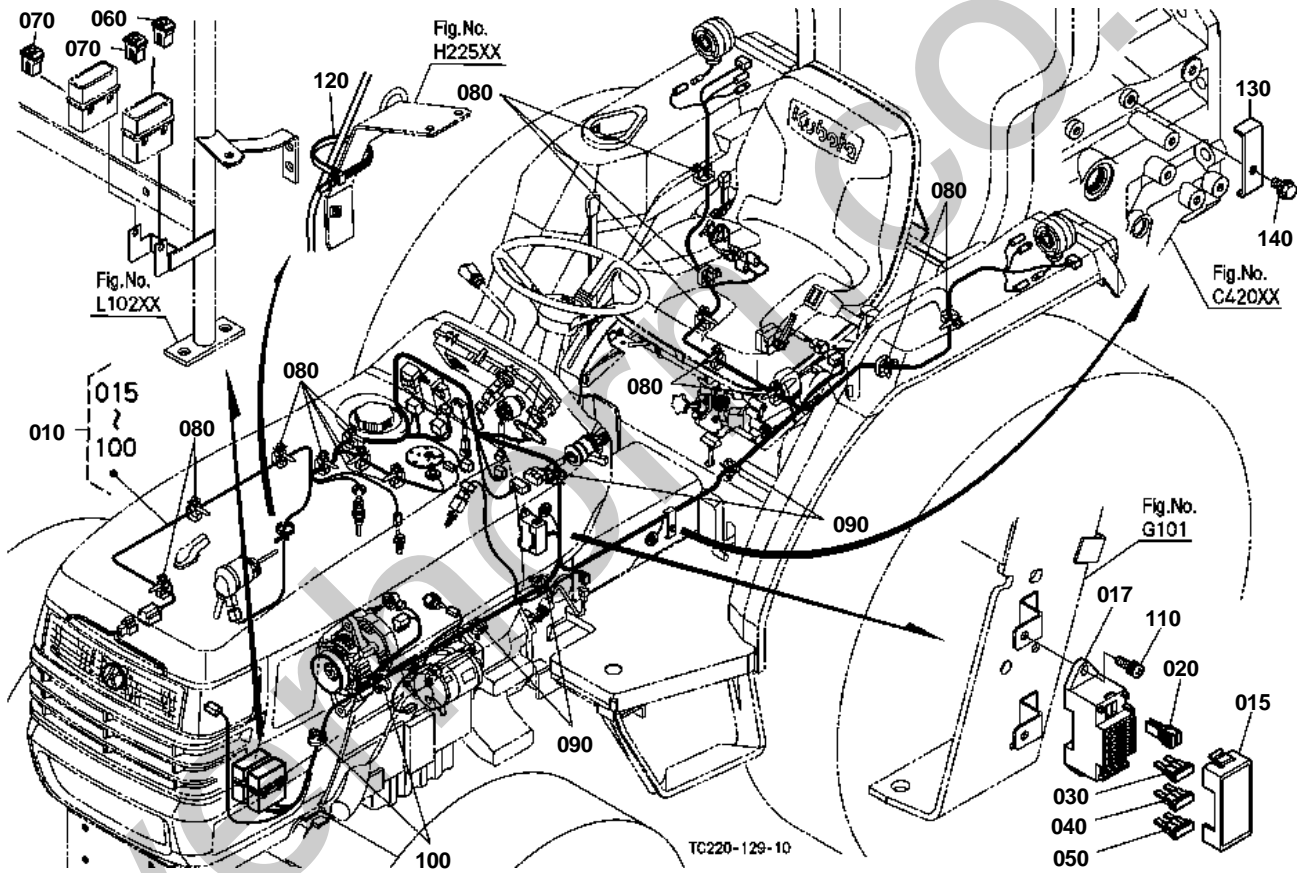

**ELECTRICAL WIRING [HST TYPE]**

↔ Interchangeable; ≠ not interchangeable; ← new for old; → old for new

REF.No	Part No.	Description	Q'ty	S.No.	I/C	REMARKS	Weight (kgf)	Weight (lb)
010	TC220-53953	WIRE HARNESS HST	1				0	0
015	TC220-30410	COVER FUSE BOX	1				0	0
017	T1060-30420	CASE FUSE BOX	1				0	0
020	T1060-30490	PULLER FUSE	1				0.005	0.011
030	T1060-30430	FUSE	4			5A	0.005	0.011
040	T1060-30440	FUSE	3			10A	0.005	0.011
050	T1060-30450	FUSE	3			15A	0.005	0.011
060	T1060-30510	FUSE	1			30A	0.007	0.0154
070	T1060-30520	FUSE	2			40A	0.007	0.0154
080	T1060-30540	CLIP	14				0.01	0.022
090	RP421-54110	CLAMP	4				0.002	0.0044
100	TD060-30570	CLIP	2				0.003	0.0066
110	31391-31140	SCREW	2				0.01	0.022
120	55311-41260	BAND CORD	1				0.007	0.0154
130	TC220-53980	GUIDE HARNESS	1				0	0
140	01754-50812	BOLT FLANGE	2				0.01	0.022

CLUTCH

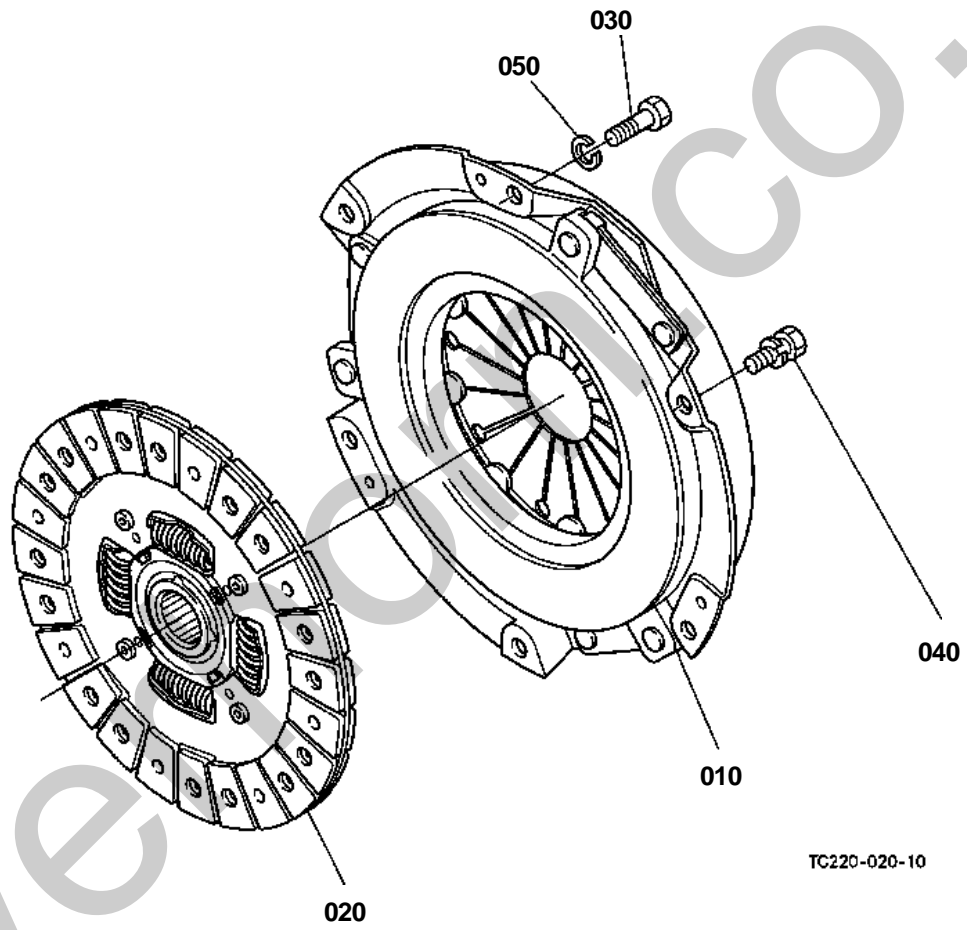

TC220-020-10



# CLUTCH

↔ Interchangeable; ≠ not interchangeable; ← new for old; → old for new

REF.No	Part No.	Description	Q'ty	S.No.	I/C	REMARKS	Weight (kgf)	Weight (lb)
010	TC210-14500	ASSY PLATE PRESSURE	1				4.7	10.34
020	T1060-20170	ASSY DISK CLUTCH	1	<=53881			0.98	2.156
020	T1060-20173	ASSY DISK CLUTCH	1	>=53882	1		0.98	2.156
030	T1270-14510	BOLT REAMER	2				0.01	0.022
040	01123-60816	BOLT	4				0.01	0.022
050	04512-60080	WASHER SPRING	2				0.002	0.0044

CLUTCH LEVER [EXCEPT HST TYPE]

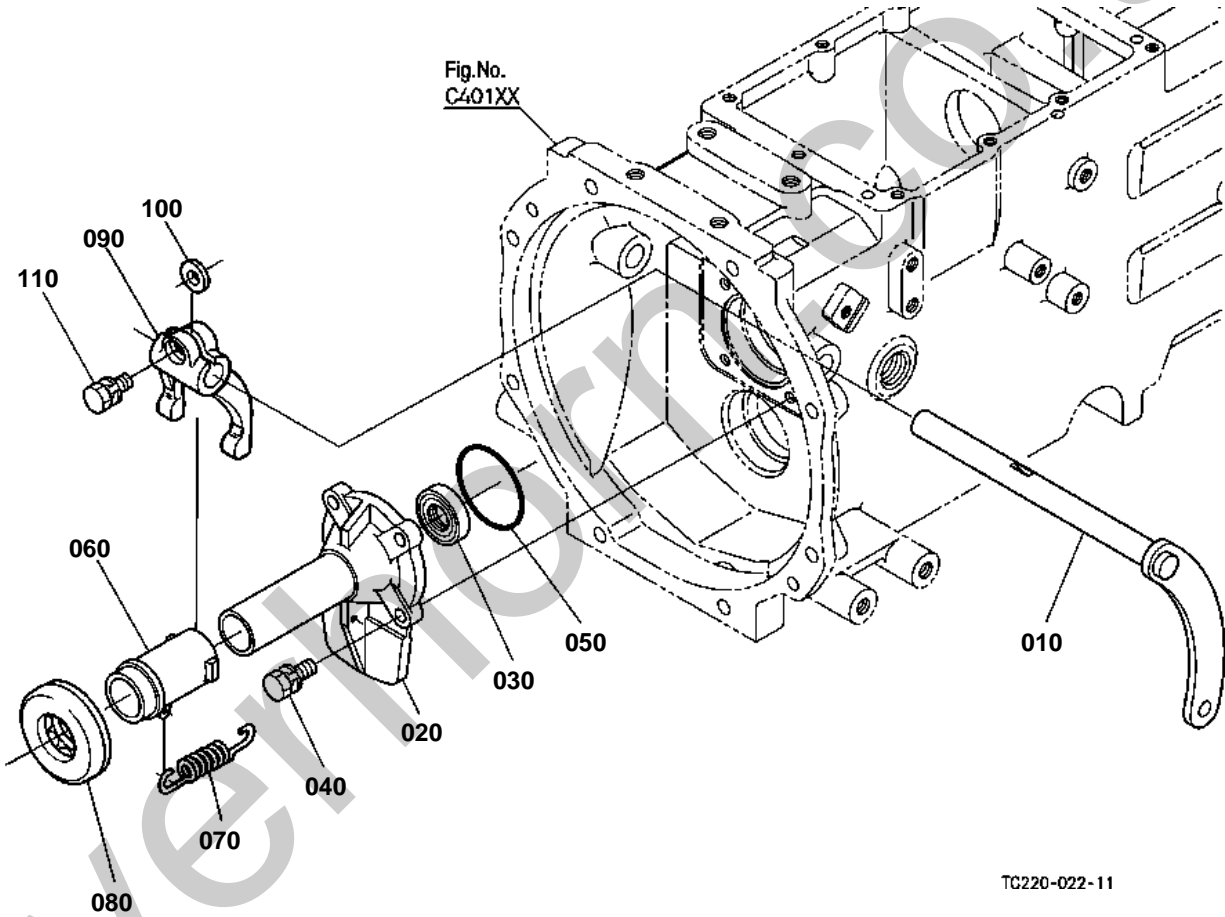

TC220-022-11



## CLUTCH LEVER [EXCEPT HST TYPE]

↔ Interchangeable; ≠ not interchangeable; ← new for old; → old for new

REF.No	Part No.	Description	Q'ty	S.No.	I/C	REMARKS	Weight (kgf)	Weight (lb)
010	TC210-14710	LEVER CLUTCH	1				0.56	1.232
020	TC210-25510	CASE PROPELLER SHAFT	1				0.407	0.8954
030	09500-25408	SEAL OIL	1	<=56477			0.01	0.022
030	6C040-13530	SEAL OIL	1	>=56478	-		0.012	0.0264
040	01123-50835	BOLT	4				0.02	0.044
050	04811-10630	O RING	1				0.001	0.0022
060	TC210-14810	HOLDER CLUTCH	1				0.46	1.012
070	34150-14840	SPRING	1				0.01	0.022
080	08490-00001	BEARING THRUST BALL	1				0.227	0.4994
090	TC210-14720	FORK CLUTCH RELEASE	1				0.25	0.55
100	31150-14780	KEY FORK	1				0.003	0.0066
110	01123-50825	BOLT	1				0.013	0.0286

CLUTCH LEVER [HST TYPE]

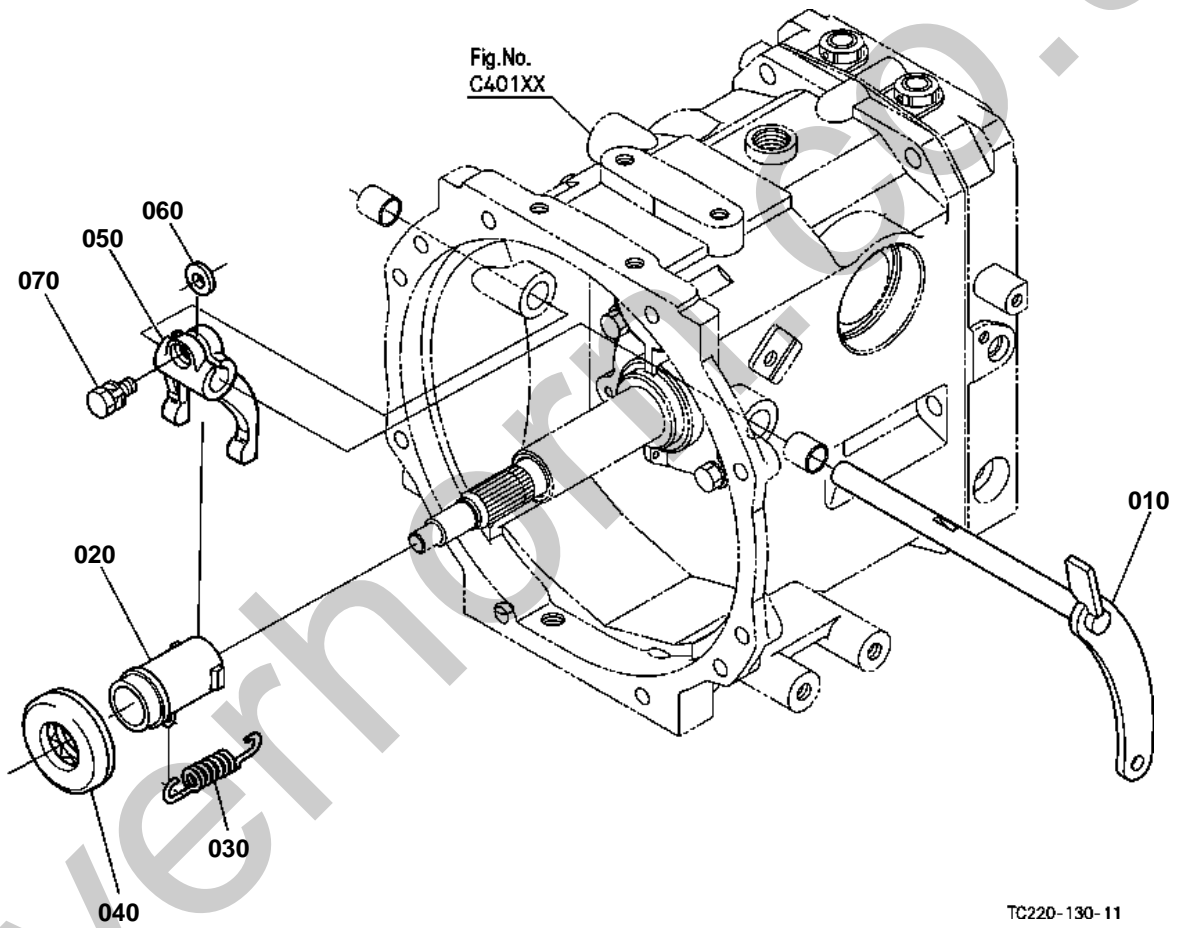



## OLD PARTS

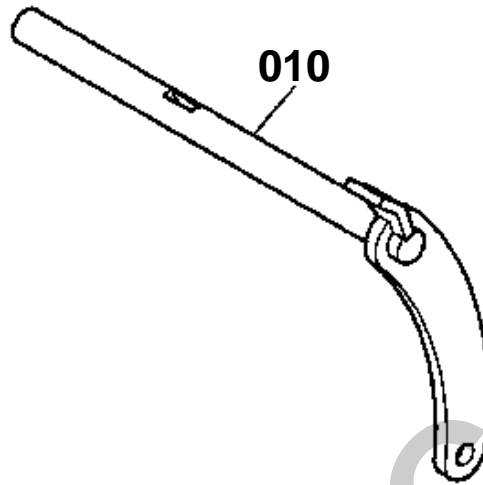

TC220-852-10



# CLUTCH LEVER [HST TYPE]

↔ Interchangeable; ≠ not interchangeable; ← new for old; → old for new

REF.No	Part No.	Description	Q'ty	S.No.	I/C	REMARKS	Weight (kgf)	Weight (lb)
010	TC220-51220	LEVER CLUTCH	1	<=57744			0	0
010	TC220-51222	LEVER CLUTCH	1	>=57745	1		0.5	1.1
020	TC210-14810	HOLDER CLUTCH	1				0.46	1.012
030	34150-14840	SPRING	1				0.01	0.022
040	08490-00001	BEARING THRUST BALL	1				0.227	0.4994
050	TC210-14720	FORK CLUTCH RELEASE	1				0.25	0.55
060	31150-14780	KEY FORK	1				0.003	0.0066
070	01123-50825	BOLT	1				0.013	0.0286

CLUTCH PEDAL

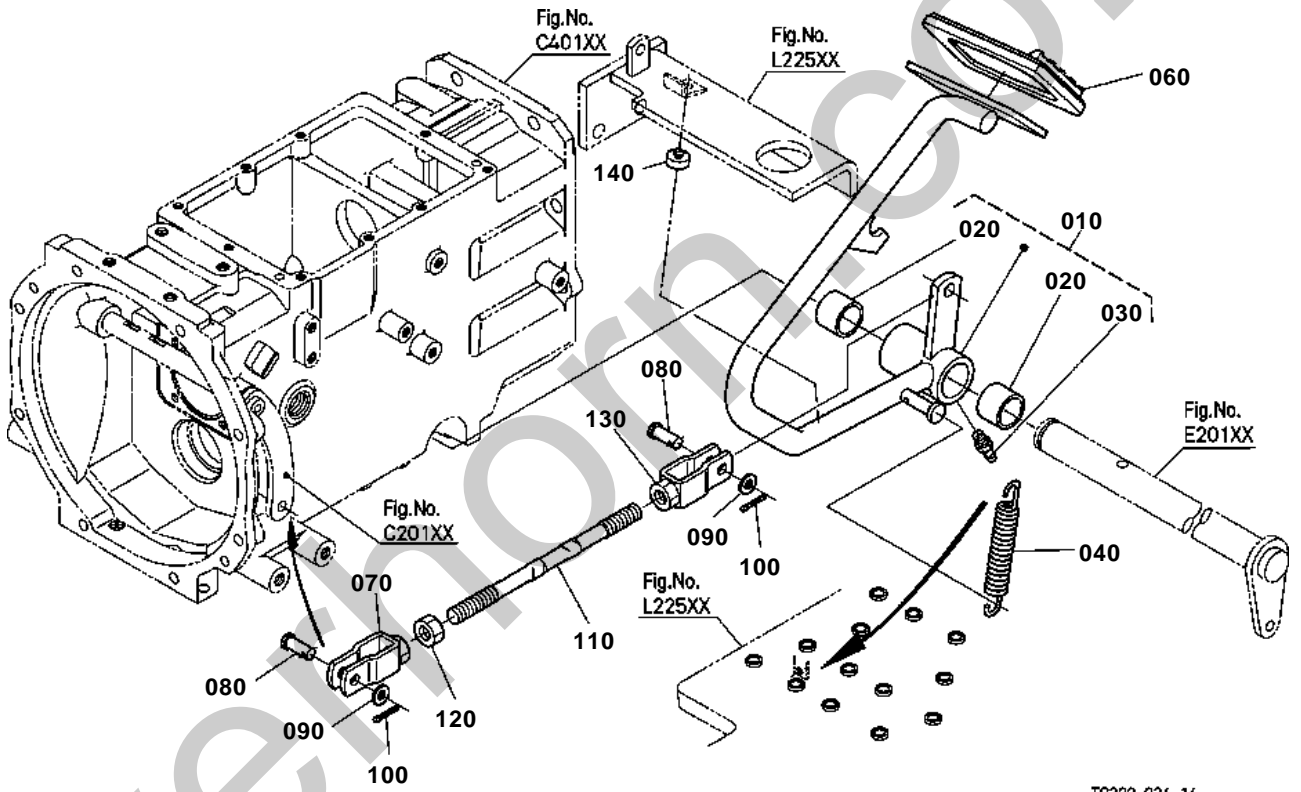

TC220-024-14

OLD PARTS

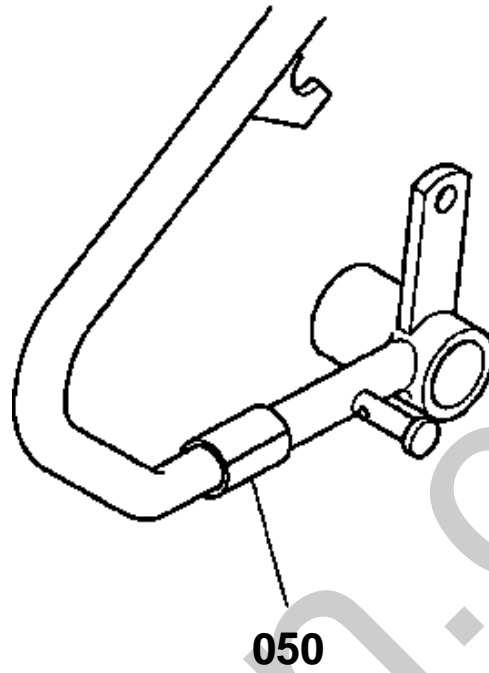

050

Silverhorn.co.uk

TC220-840-10



## CLUTCH PEDAL

↔ Interchangeable; ≠ not interchangeable; ← new for old; → old for new

REF.No	Part No.	Description	Q'ty	S.No.	I/C	REMARKS	Weight (kgf)	Weight (lb)
010	TC210-15720	ASSY PEDAL CLUTCH	1				2	4.4
020	08511-02520	BUSH	2				0.02	0.044
030	06613-10675	NIPPLE GREASE	1				0.003	0.0066
040	37150-15840	SPRING	1				0.06	0.132
050	32400-15830	CUSHION	1	<=52427			0.005	0.011
060	37410-44120	COVER PEDAL	1	<=52160			0	0
060	T2050-44120	COVER PEDAL	1	>=52161	-		0.07	0.154
070	TC220-15630	U JOINT	1				0.07	0.154
080	05122-51022	PIN JOINT	2				0.014	0.0308
090	04013-60100	WASHER PLAIN	2				0.003	0.0066
100	05511-50318	PIN SPLIT	2				0.001	0.0022
110	TC220-15650	ROD CLUTCH	1				0.14	0.308
120	02172-50120	NUT	1				0.01	0.022
130	TC220-15640	U JOINT	1				0.07	0.154
140	6C040-42342	CUSHION	1	>=52428			0.005	0.011

CLUTCH HOUSING [EXCEPT HST TYPE]

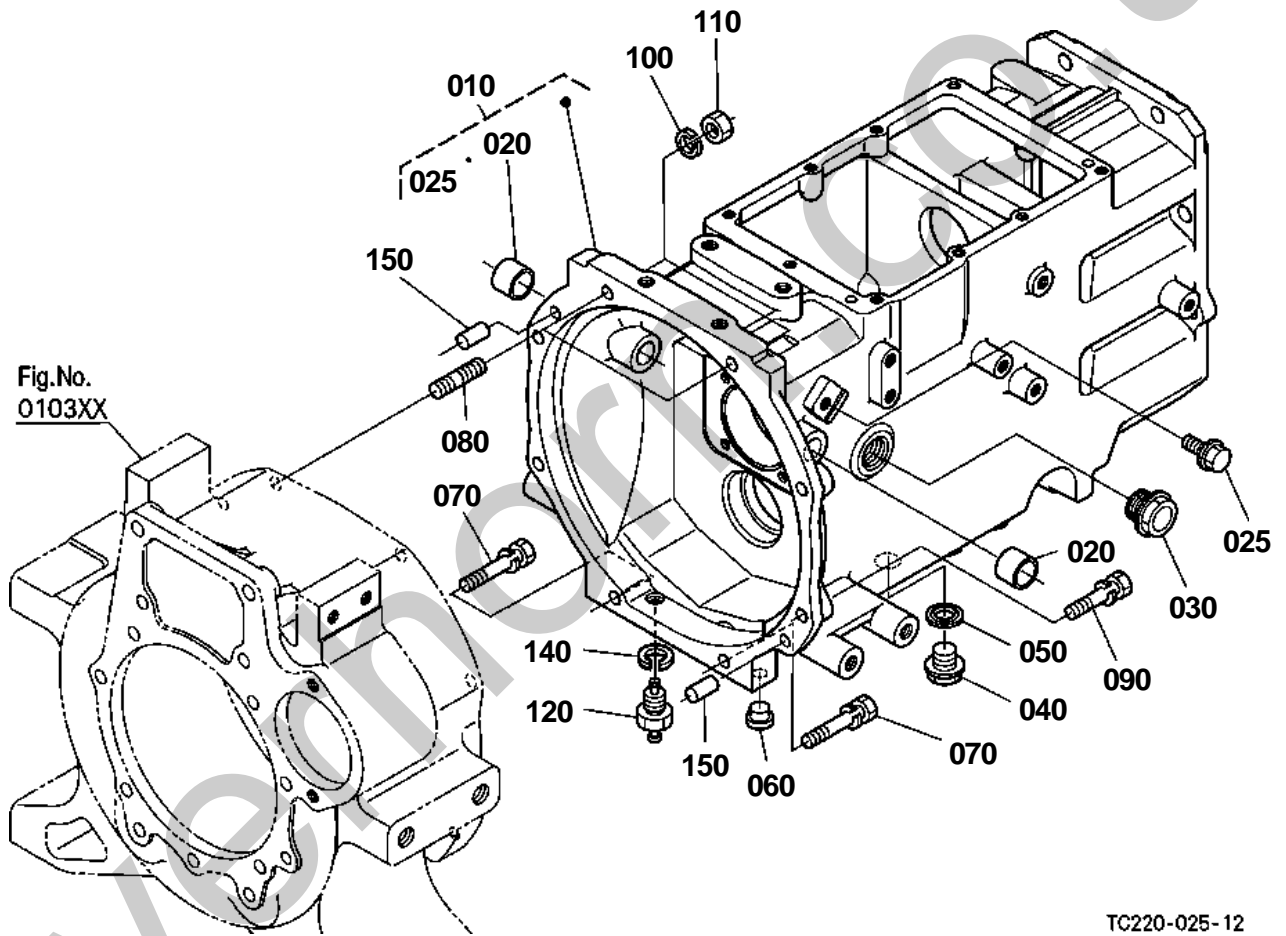

TC220-025-12

## OLD PARTS

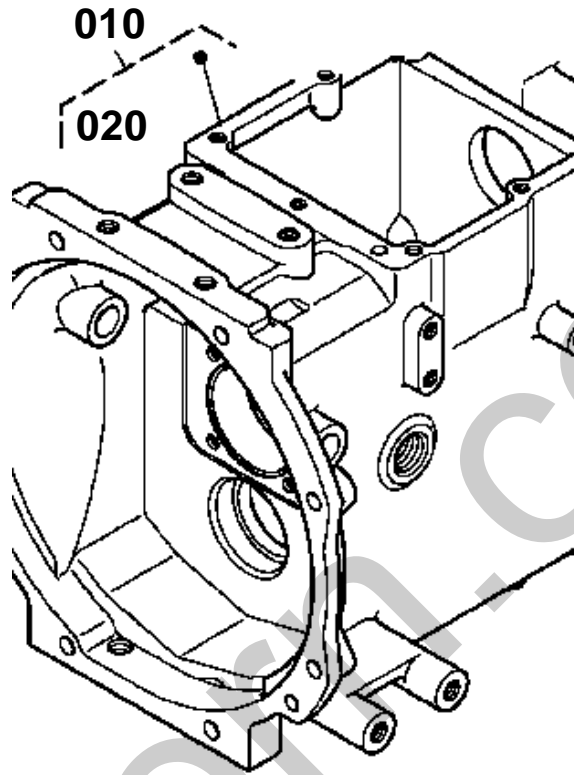

TC220-842-10



## CLUTCH HOUSING [EXCEPT HST TYPE]

↔ Interchangeable; ≠ not interchangeable; ← new for old; → old for new

REF.No	Part No.	Description	Q'ty	S.No.	I/C	REMARKS	Weight (kgf)	Weight (lb)
010	TC210-99202	ASSY HOUSING CLUTCH	1	<=51027			0	0
010	TC210-99203	ASSY HOUSING CLUTCH	1	>=51028	-		42.5	93.5
010	TC210-99204	ASSY HOUSING CLUTCH	1	>=53277	-		42.5	93.5
010	TC210-99205	ASSY HOUSING CLUTCH	1	>=55744	-		42.5	93.5
020	08511-01515	BUSH	2				0.002	0.0044
025	01774-61020	BOLT FLANGE	1	>=53277			0.022	0.0484
030	TC220-14610	GAUGE OIL	1				0.01	0.022
040	15512-96010	PLUG DRAIN	1				0.101	0.2222
050	04717-02150	WASHER WITH RUBBER	1				0.004	0.0088
060	32210-27580	PLUG	2				0.001	0.0022
070	01133-51070	BOLT	2				0.047	0.1034
080	01517-51040	STUD	2				0.03	0.066
090	01133-51040	BOLT	4				0.03	0.066
100	04512-60100	WASHER SPRING	2				0.002	0.0044
110	02176-50100	NUT	2				0.005	0.011
120	32430-14270	KIT PLUG	1				0.04	0.088
130	99999-99999	BLANK	0				0	0
140	04512-60140	WASHER SPRING	1				0.008	0.0176
150	05012-01018	PIN STRAIGHT	2				0.012	0.0264



CLUTCH HOUSING [HST TYPE]

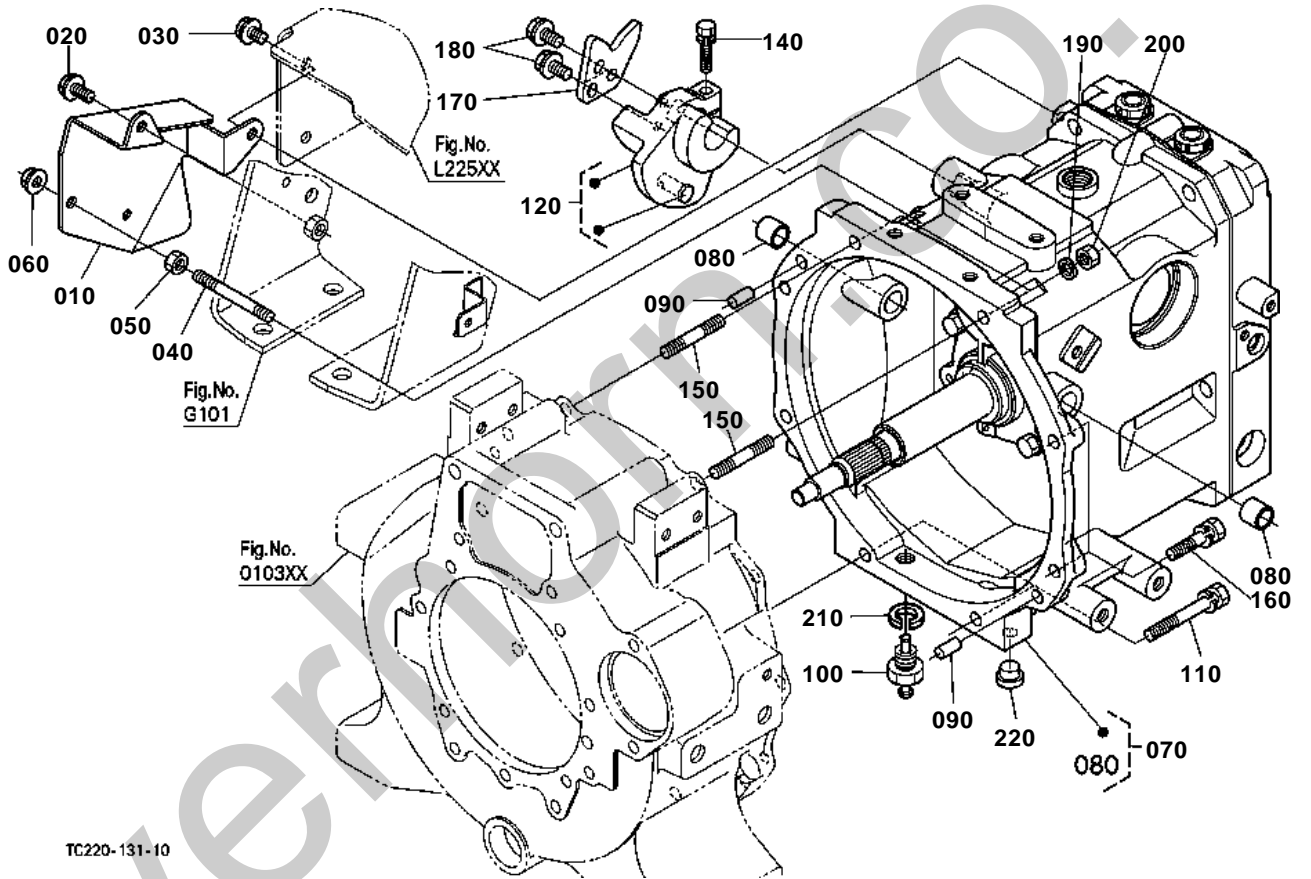

TC220-131-10



# CLUTCH HOUSING [HST TYPE]

↔ Interchangeable; ≠ not interchangeable; ← new for old; → old for new

REF.No	Part No.	Description	Q'ty	S.No.	I/C	REMARKS	Weight (kgf)	Weight (lb)
010	TC220-57550	COVER NEUTRAL HOLDER	1				0	0
020	01754-50816	BOLT FLANGE	1				0.011	0.0242
030	01754-50812	BOLT FLANGE	1				0.01	0.022
040	01513-50865	STUD	1				0.026	0.0572
050	02156-50080	NUT	1				0.004	0.0088
060	02751-50080	NUT FLANGE	1				0.006	0.0132
070	TC220-59990	ASSY HST	1				0	0
080	08511-01515	BUSH	2				0.002	0.0044
090	05012-01018	PIN STRAIGHT	2				0.012	0.0264
100	32430-14270	KIT PLUG	1				0.04	0.088
110	01133-51070	BOLT	2				0.047	0.1034
120	TC220-59343	ASSY HOLDER	1				0	0
130	99999-99999	BLANK	0				0	0
140	01123-50835	BOLT	1				0.02	0.044
150	01517-51040	STUD	2				0.03	0.066
160	01133-51040	BOLT	4				0.03	0.066
170	TC220-59363	PLATE HST TRUNNION	1				0	0
180	01754-50816	BOLT FLANGE	3				0.011	0.0242
190	04512-60100	WASHER SPRING	2				0.002	0.0044
200	02176-50100	NUT	2				0.005	0.011
210	04512-60140	WASHER SPRING	1				0.008	0.0176
220	32210-27580	PLUG	4				0.001	0.0022

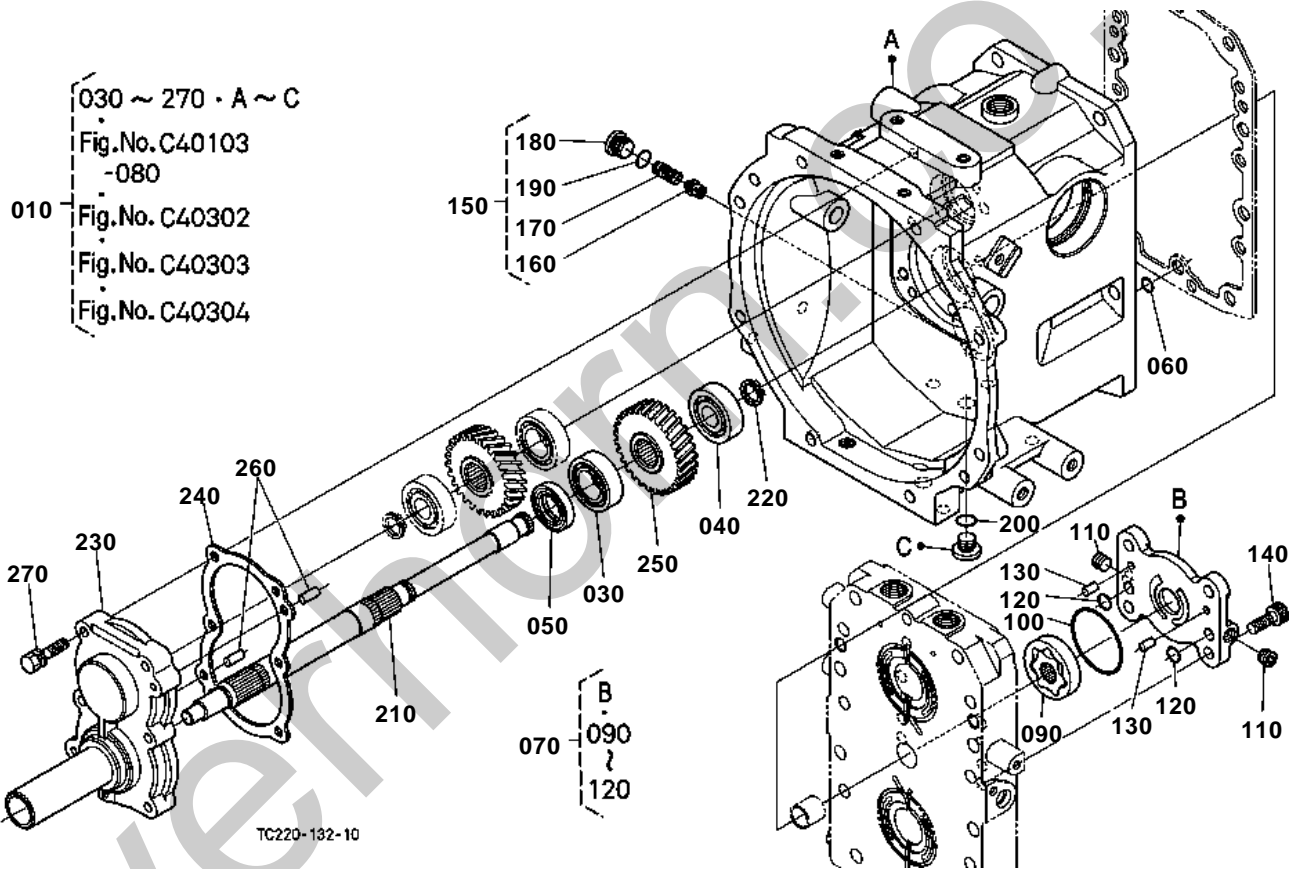



## HST(INPUT SHAFT) [COMPONENT PARTS] [HST TYPE]

↔ Interchangeable; ≠ not interchangeable; ← new for old; → old for new

REF.No	Part No.	Description	Q'ty	S.No.	I/C	REMARKS	Weight (kgf)	Weight (lb)
010	TC220-59990	ASSY HST	1				0	0
020	99999-99999	BLANK	0				0	0
030	TC220-53520	BEARING BALL	1				0	0
040	TC220-52300	BEARING BALL	1				0.145	0.319
050	58700-11290	SEAL OIL	1				0.012	0.0264
060	04817-00100	O RING	1				0.001	0.0022
070	TC220-59500	ASSY PUMP CHARGE	1				0	0
080	99999-99999	BLANK	0				0	0
090	TC220-59520	ROTOR	1				0	0
100	04811-06630	O RING	1				0.001	0.0022
110	K7001-39620	PLUG	2				0.005	0.011
120	04817-00140	O RING	2				0.001	0.0022
130	K7561-14090	PIN STRAIGHT	2				0.002	0.0044
140	01315-11025	BOLT HEX-SOC-HD	4				0.024	0.0528
150	TC220-59600	ASSY VALVE CHARGE	1				0	0
160	66363-39710	POPPET L	1				0.006	0.0132
170	66363-39720	SPRING	1				0.01	0.022
180	5H600-12620	PLUG	1				0.021	0.0462
190	04817-00140	O RING	1				0.001	0.0022
200	04817-00110	O RING	1				0.001	0.0022
210	TC220-51400	SHAFT INPUT	1				1.15	2.53
220	04612-00200	CIR CLIP EXTERNAL	1				0.001	0.0022
230	TC220-51100	CASE INPUT SHAFT	1				0	0
240	TC220-51110	GASKET	1				0.008	0.0176
250	TC220-52100	GEAR INPUT	1			28T	0.635	1.397
260	K7561-11180	PIN STRAIGHT	2				0.005	0.011
270	01123-50835	BOLT	6				0.02	0.044

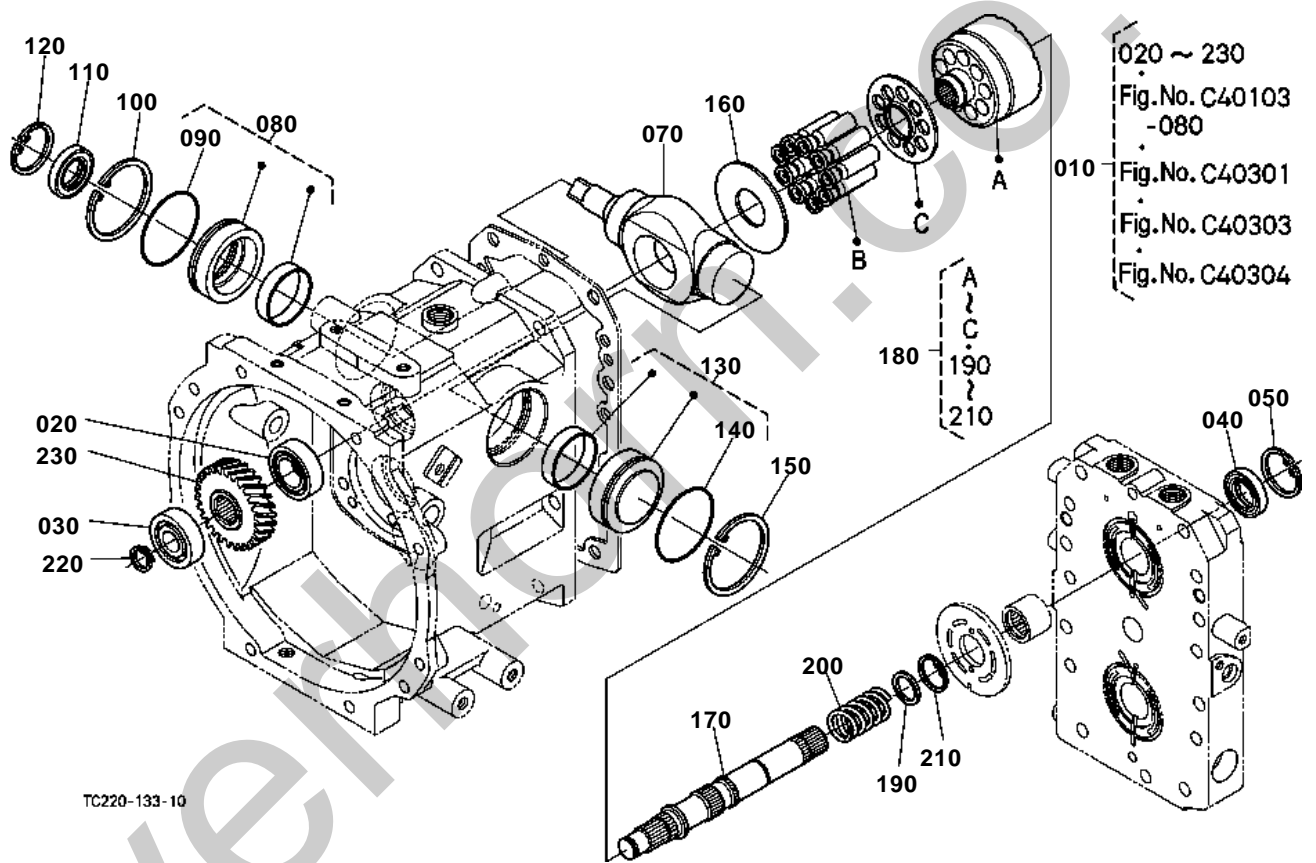



## HST(PUMP SHAFT) [COMPONENT PARTS] [HST TYPE]

↔ Interchangeable; ≠ not interchangeable; ← new for old; → old for new

REF.No	Part No.	Description	Q'ty	S.No.	I/C	REMARKS	Weight (kgf)	Weight (lb)
010	TC220-59990	ASSY HST	1				0	0
020	TC220-53520	BEARING BALL	1				0	0
030	TC220-52300	BEARING BALL	1				0.145	0.319
040	58700-11290	SEAL OIL	1				0.012	0.0264
050	04611-00400	CIR CLIP INTERNAL	1				0.005	0.011
060	99999-99999	BLANK	0				0	0
070	5H630-10110	PLATE	1				1.61	3.542
080	5H630-10200	ASSY COVER(A)	1				0.13	0.286
090	04811-50650	O RING	1				0.002	0.0044
100	04611-00720	CIR CLIP INTERNAL	1				0.018	0.0396
110	66363-39490	SEAL OIL	1				0.02	0.044
120	04611-00450	CIR CLIP INTERNAL	1				0.01	0.022
130	5H630-10300	ASSY COVER(B)	1				0.14	0.308
140	04811-50650	O RING	1				0.002	0.0044
150	04611-00720	CIR CLIP INTERNAL	1				0.018	0.0396
160	6A110-35150	COLLAR THRUST	1				0.033	0.0726
170	TC220-58120	SHAFT	1				0.87	1.914
180	TC220-58500	ASSY BLOCK CYL.	1				0	0
190	66363-39240	HOLDER SPRING	1				0.006	0.0132
200	66363-39250	SPRING	1				0.06	0.132
210	04611-00350	CIR CLIP INTERNAL	1				0.003	0.0066
220	04612-00200	CIR CLIP EXTERNAL	1				0.001	0.0022
230	TC220-52200	GEAR INPUT	1			27T	0.58	1.276

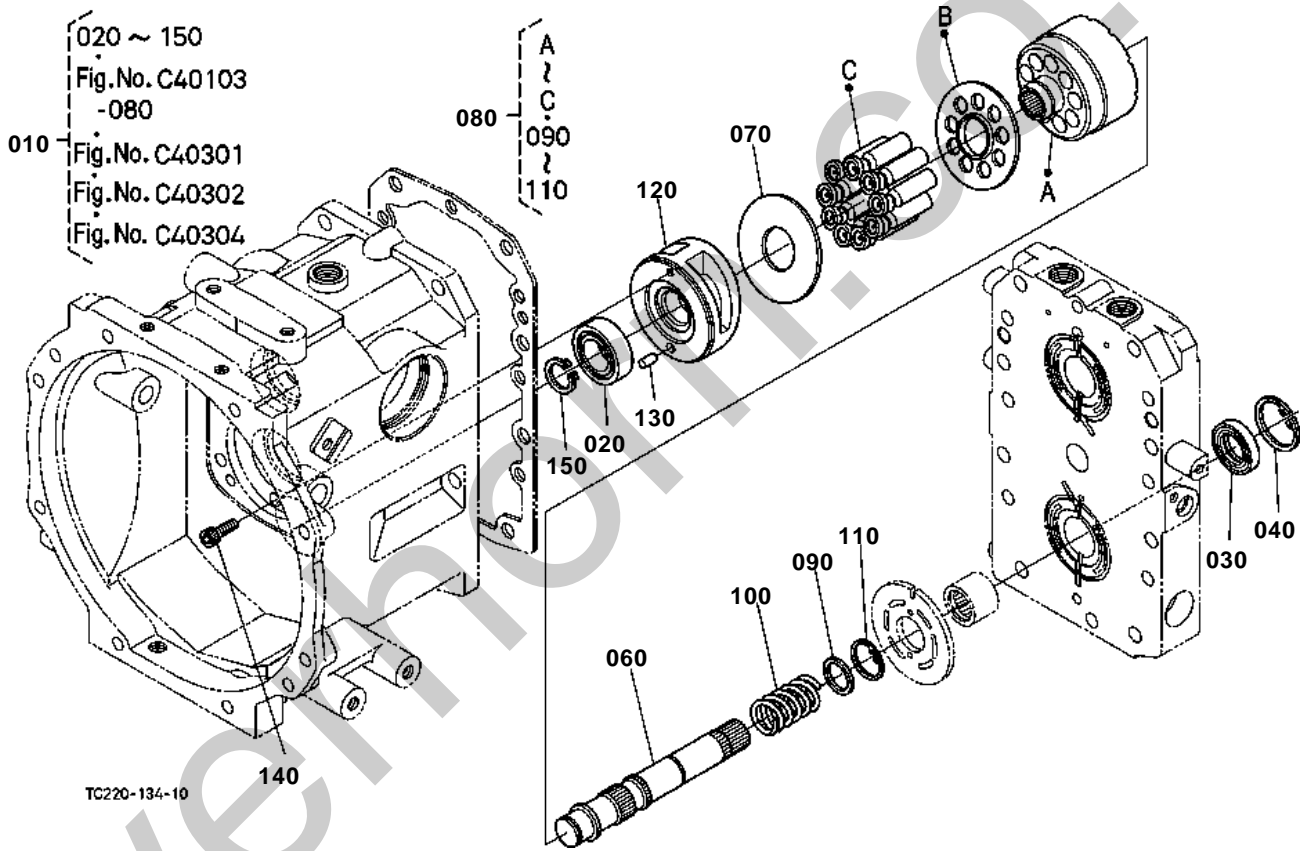



# HST(MOTOR SHAFT) [COMPONENT PARTS] [HST TYPE]

↔ Interchangeable; ≠ not interchangeable; ← new for old; → old for new

REF.No	Part No.	Description	Q'ty	S.No.	I/C	REMARKS	Weight (kgf)	Weight (lb)
010	TC220-59990	ASSY HST	1				0	0
020	TC220-53520	BEARING BALL	1				0	0
030	58700-11290	SEAL OIL	1				0.012	0.0264
040	04611-00400	CIR CLIP INTERNAL	1				0.005	0.011
050	99999-99999	BLANK	0				0	0
060	TC220-58130	SHAFT	1				0	0
070	6A110-35150	COLLAR THRUST	1				0.033	0.0726
080	TC220-58600	ASSY BLOCK CYL.	1				0	0
090	66363-39240	HOLDER SPRING	1				0.006	0.0132
100	66363-39250	SPRING	1				0.06	0.132
110	04611-00350	CIR CLIP INTERNAL	1				0.003	0.0066
120	TC220-58860	SWASH PLATE MOTER	1				0	0
130	K7561-14090	PIN STRAIGHT	1				0.002	0.0044
140	01311-10625	BOLT HEX-SOC-HD	1				0.006	0.0132
150	04612-00250	CIR CLIP EXTERNAL	1				0.002	0.0044



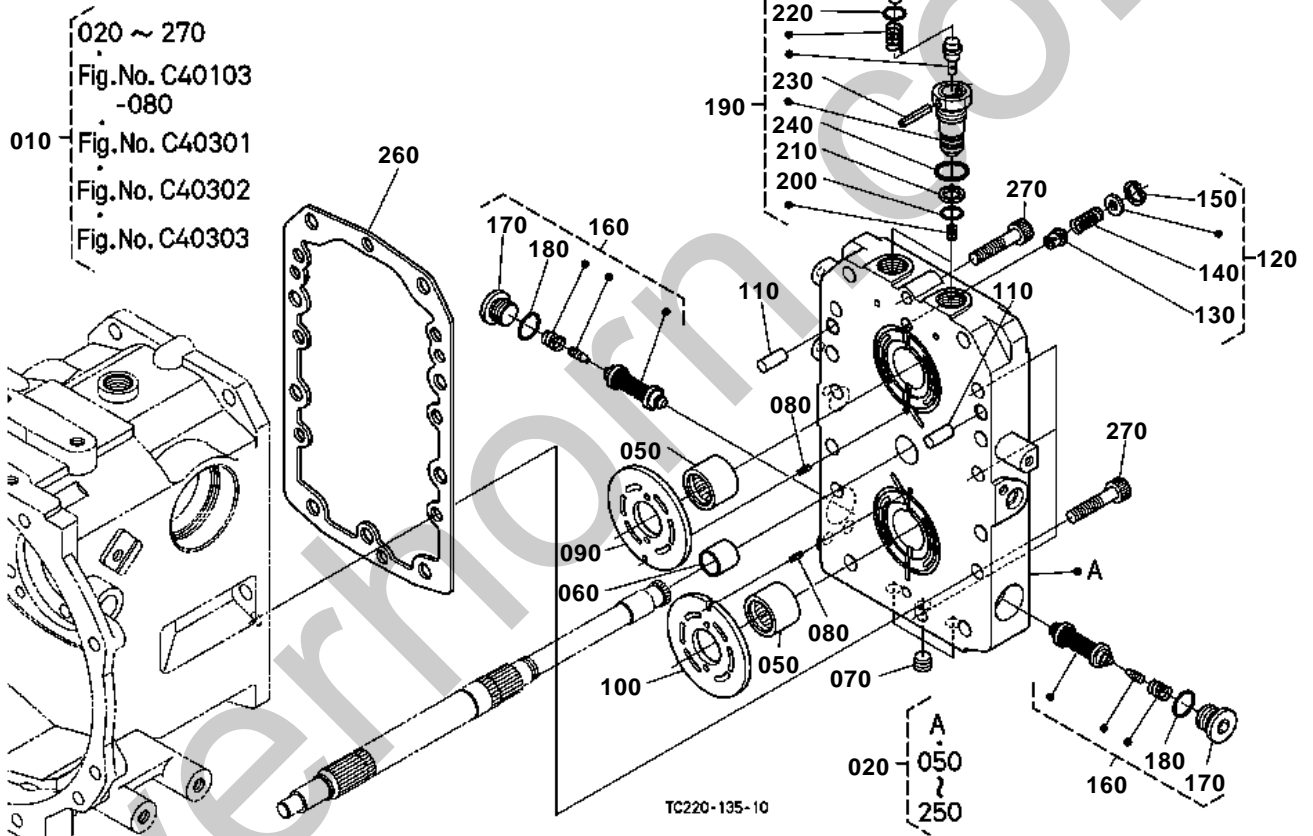



## HST(VALUE) [COMPONENT PARTS] [HST TYPE]

↔ Interchangeable; ≠ not interchangeable; ← new for old; → old for new

REF.No	Part No.	Description	Q'ty	S.No.	I/C	REMARKS	Weight (kgf)	Weight (lb)
010	TC220-59990	ASSY HST	1				0	0
020	TC220-58950	COMP.COVER	1				11	24.2
030	99999-99999	BLANK	0				0	0
040	99999-99999	BLANK	0				0	0
050	52807-11160	BEARING NEEDLE	2				0.045	0.099
060	TC220-59540	BUSH	1				0	0
070	K7001-39620	PLUG	3				0.005	0.011
080	05411-00414	PIN SPRING	2				0.001	0.0022
090	5H630-10720	PLATE VALVE	1				0.15	0.33
100	5H630-10730	PLATE VALVE	1				0.15	0.33
110	TC220-58920	PIN STRAIGHT	2				0	0
120	37590-39700	ASSY VALVE RELIEF	1				0.01	0.022
130	66363-39710	POPPET L	1				0.006	0.0132
140	66363-39720	SPRING	1				0.01	0.022
150	04611-00180	CIR CLIP INTERNAL	1				0.001	0.0022
160	K7561-14900	ASSY VALVE RELIEF F	2	<=55743			0.08	0.176
160	TC220-59400	ASSY VALVE	2	>=55744	→		0	0
170	5H600-11820	PLUG	2				0.005	0.011
180	04817-00180	O RING	1				0.003	0.0066
190	6C070-11650	ASSY VALVE NUETRAL	2				0.1	0.22
200	04817-00120	O RING	2				0.001	0.0022
210	66363-39630	RING BACK UP	2				0.001	0.0022
220	04817-00100	O RING	2				0.001	0.0022
230	05411-00325	PIN SPRING	2				0.001	0.0022
240	04817-00180	O RING	2				0.003	0.0066
250	04014-50060	WASHER PLAIN	2				0.001	0.0022
260	TC220-58190	GASKET	1				0.012	0.0264
270	01315-11045	BOLT HEX-SOC-HD	8				0.035	0.077

TRANSMISSION CASE [EXCEPT HST TYPE]

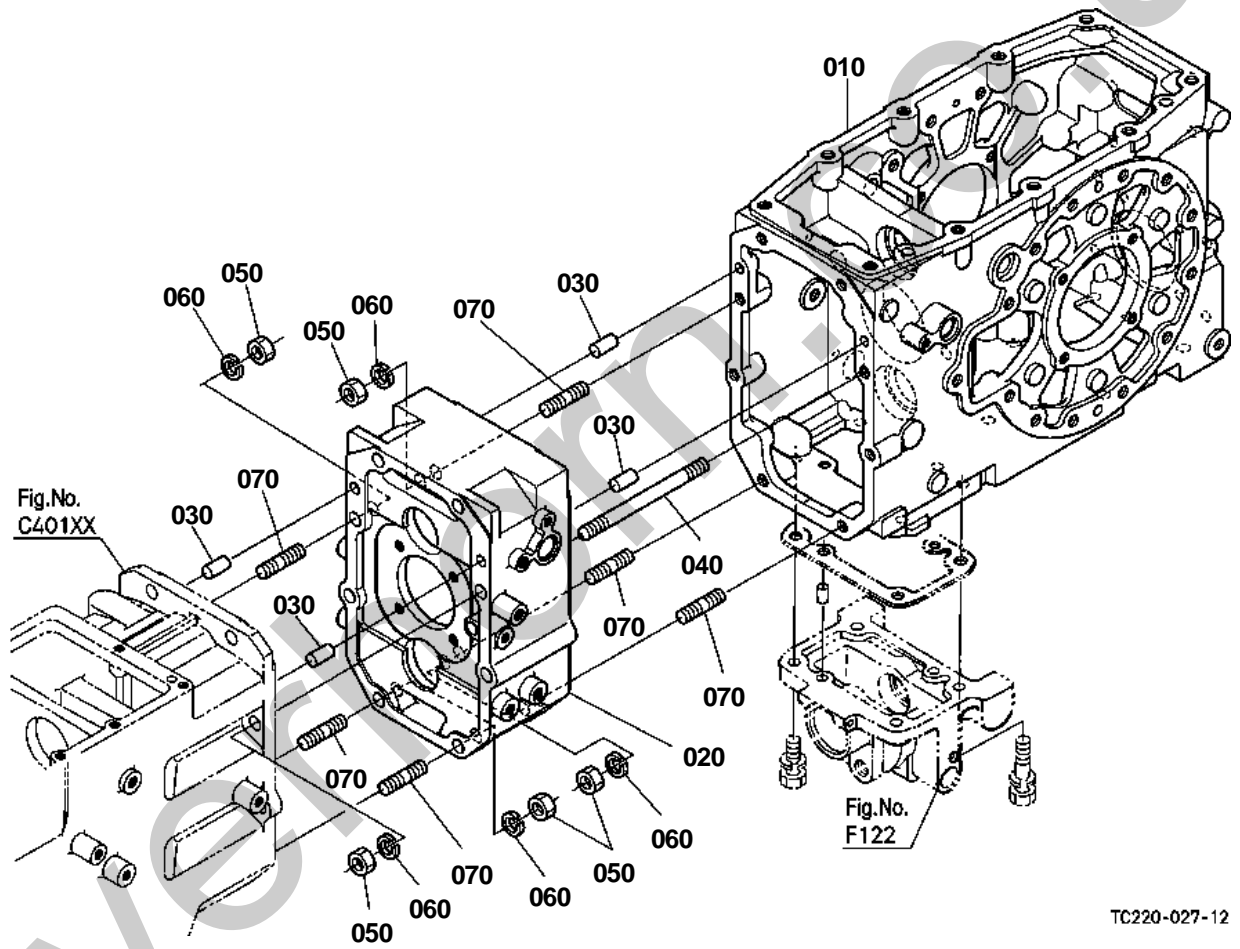

TC220-027-12

OLD PARTS

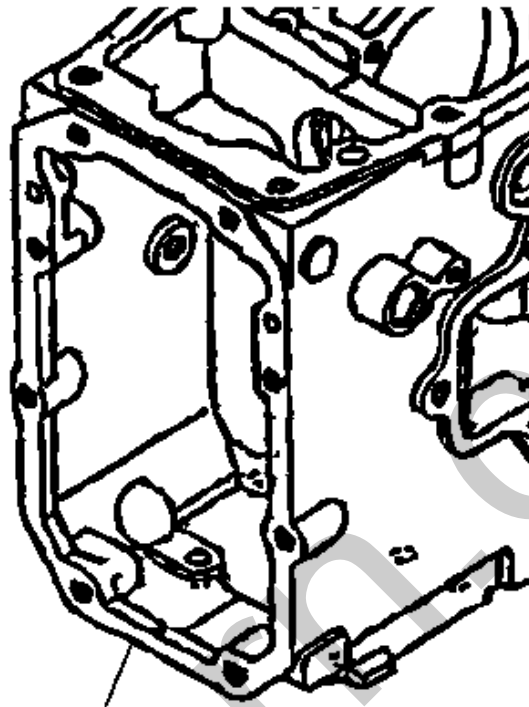

010

TC220-803-11



### TRANSMISSION CASE [EXCEPT HST TYPE]

↔ Interchangeable; ≠ not interchangeable; ← new for old; → old for new

REF.No	Part No.	Description	Q'ty	S.No.	I/C	REMARKS	Weight (kgf)	Weight (lb)
010	TC220-21110	CASE TRANSMISSION	1	<=50333			0	0
010	TC220-21114	CASE TRANSMISSION	1	>=50334	-		28.1	61.82
010	TC220-21117	CASE TRANSMISSION	1	>=57745	1		28.1	61.82
020	TC220-21150	CASE MID	1	<=50333			0	0
020	TC220-21154	CASE MID	1	>=50334	-		10.1	22.22
030	05012-01018	PIN STRAIGHT	4				0.012	0.0264
040	TC220-14180	STUD	5				0.13	0.286
050	02176-50120	NUT	11				0.01	0.022
060	04512-60120	WASHER SPRING	11				0.005	0.011
070	01574-61235	STUD	6				0.04	0.088

TRANSMISSION CASE [HST TYPE]

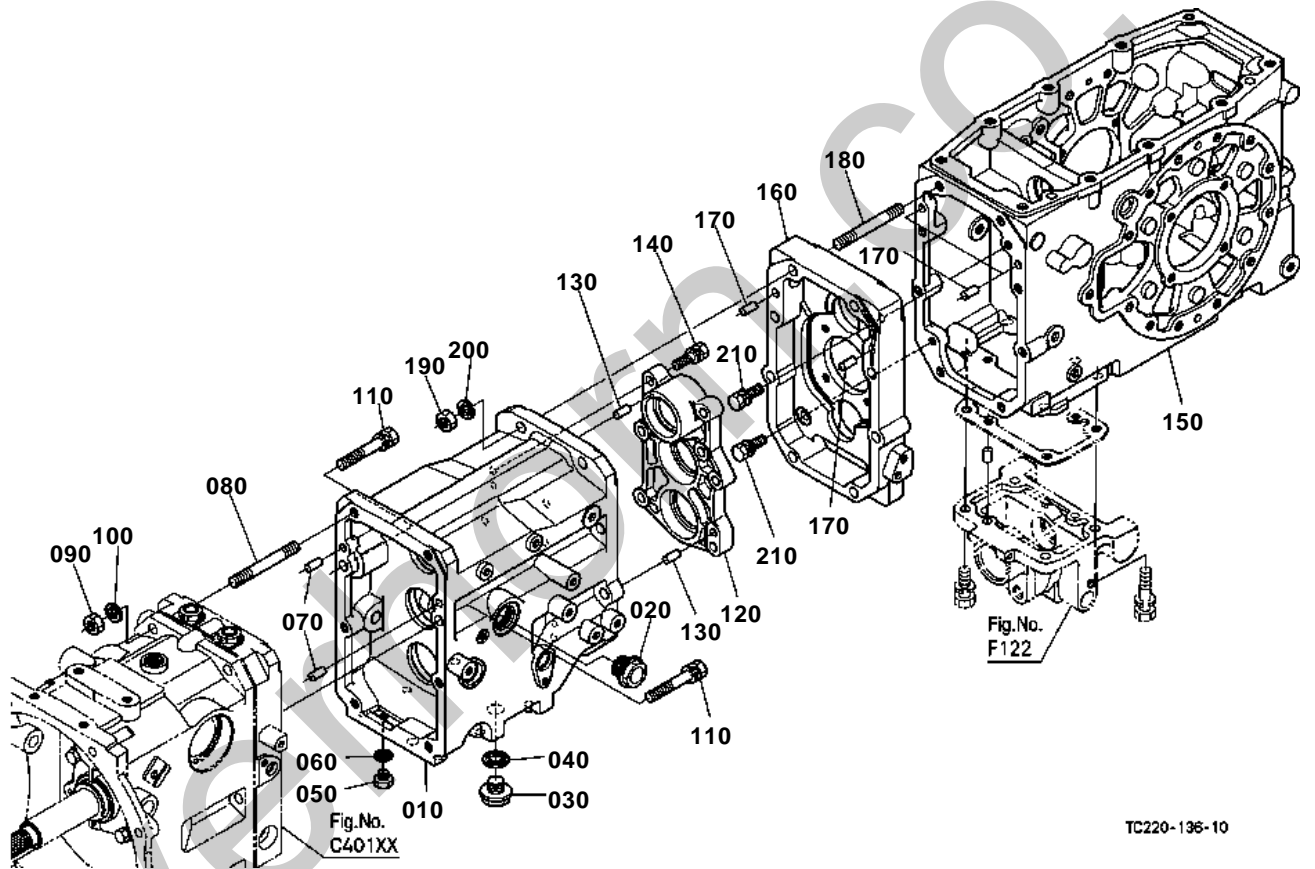

TC220-136-10



# TRANSMISSION CASE [HST TYPE]

↔ Interchangeable; ≠ not interchangeable; ← new for old; → old for new

REF.No	Part No.	Description	Q'ty	S.No.	I/C	REMARKS	Weight (kgf)	Weight (lb)
010	TC220-50322	CASE MID	1				21	46.2
020	TC220-14610	GAUGE OIL	1				0.01	0.022
030	15512-96010	PLUG DRAIN	1				0.101	0.2222
040	04717-02150	WASHER WITH RUBBER	1				0.004	0.0088
050	06331-35010	PLUG	1				0.012	0.0264
060	04717-01000	WASHER WITH RUBBER	1				0.001	0.0022
070	05012-01018	PIN STRAIGHT	2				0.012	0.0264
080	01574-51275	STUD	6				0.074	0.1628
090	02176-50120	NUT	6				0.01	0.022
100	04512-60120	WASHER SPRING	6				0.005	0.011
110	01133-51275	BOLT	2				0.02	0.044
120	TC220-50330	HOLDER BEARING	1				0	0
130	05012-00818	PIN STRAIGHT	2				0.013	0.0286
140	01133-51035	BOLT	6				0.03	0.066
150	TC220-50420	CASE TRANSMISSION	1	<=57744			28.1	61.82
150	TC220-50422	CASE TRANSMISSION	1	>=57745	1		28.1	61.82
160	TC220-50512	SPACER TRANSMISSION	1				0	0
170	05012-01018	PIN STRAIGHT	4				0.012	0.0264
180	35340-27380	STUD	8				0.08	0.176
190	35340-27360	NUT	8				0.015	0.033
200	04512-60120	WASHER SPRING	8				0.005	0.011
210	01133-51030	BOLT	2				0.025	0.055

MAIN SHAFT [EXCEPT HST TYPE]

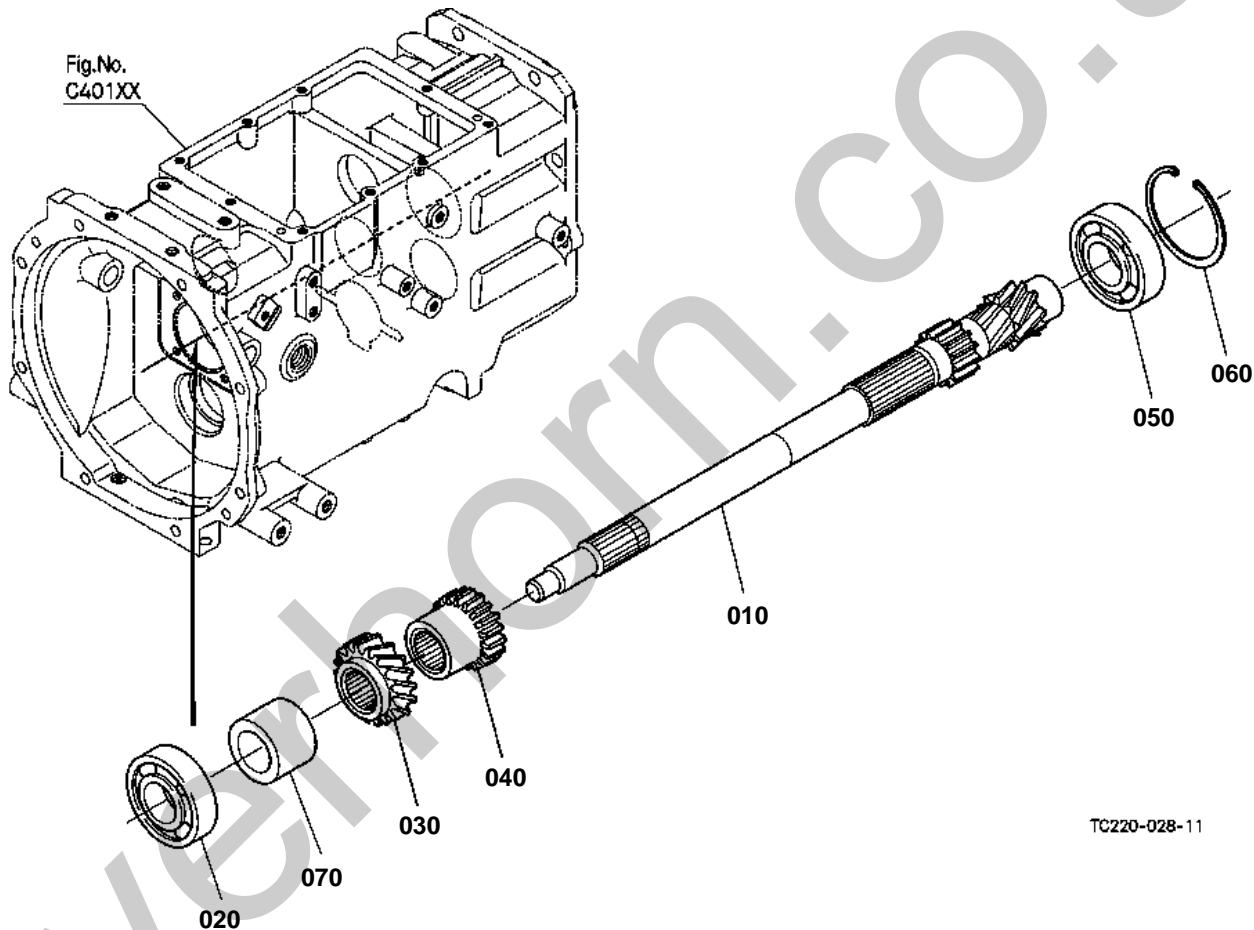

TC220-028-11





# MAIN SHAFT [EXCEPT HST TYPE]

↔ Interchangeable; ≠ not interchangeable; ← new for old; → old for new

REF.No	Part No.	Description	Q'ty	S.No.	I/C	REMARKS	Weight (kgf)	Weight (lb)
010	TC210-21510	GEAR-SHAFT MAIN	1	<=56786			0	0
010	TC210-21512	GEAR-SHAFT MAIN	1	>=56787	-		1.85	4.07
020	08101-06305	BEARING BALL	1				0.23	0.506
030	35110-21530	GEAR	1			23T	0.355	0.781
040	37150-21520	GEAR	1			17T	0.225	0.495
050	35890-41290	BEARING BALL	1				0.233	0.5126
060	04611-00620	CIR CLIP INTERNAL	1				0.011	0.0242
070	TC210-21540	COLLAR	1	<=53276			0.22	0.484
070	TC210-21543	COLLAR	1	>=53277	-		0.22	0.484

COUNTERSHAFT [EXCEPT HST TYPE]

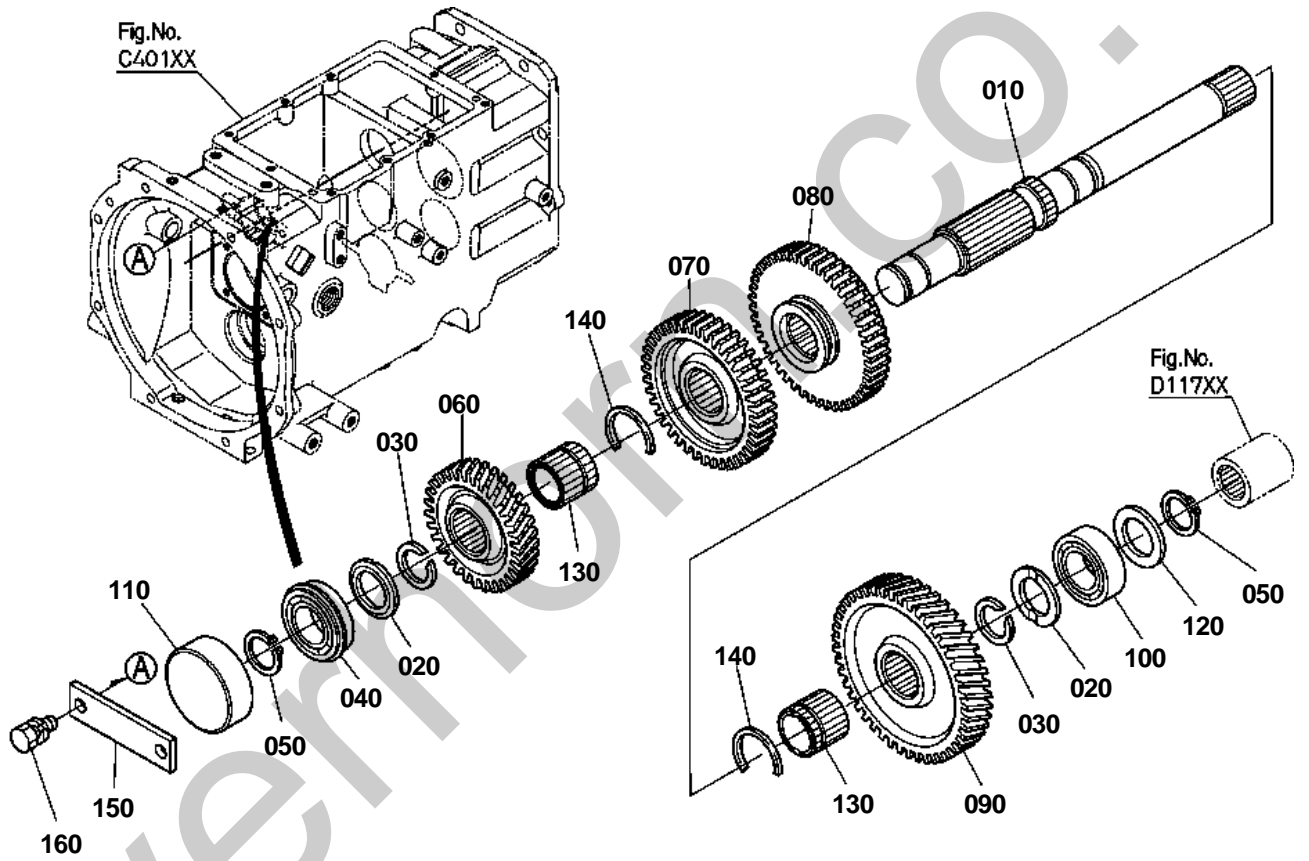

TC220-030-21

**COUNTERSHAFT [EXCEPT HST TYPE]**

↔ Interchangeable; ≠ not interchangeable; ← new for old; → old for new

REF.No	Part No.	Description	Q'ty	S.No.	I/C	REMARKS	Weight (kgf)	Weight (lb)
010	TC220-21610	COUNTERSHAFT	1				1.52	3.344
020	37150-21760	COLLAR THRUST	2				0.017	0.0374
030	37150-21790	CIR-CLIP	2				0.001	0.0022
040	TC220-22150	BEARING BALL	1				0.13	0.286
050	37150-21551	CIR CLIP EXTERNAL	2				0.005	0.011
060	TC220-21710	GEAR MAIN	1			32T	0.46	1.012
070	TC220-21720	GEAR	1	<=55198		41T	0.855	1.881
070	TC220-21722	GEAR	1	>=55199	-	41T	0.855	1.881
080	TC220-21730	GEAR	1	<=54355		45T	1.28	2.816
080	TC220-21732	GEAR	1	>=54356	-	45T	1.28	2.816
090	TC220-21740	GEAR MAIN	1			45T	1.055	2.321
100	TC220-22140	BEARING BALL	1				0.128	0.2816
110	34150-21650	COVER BEARING	1				0.07	0.154
120	34150-21560	WASHER	1				0.01	0.022
130	TC220-21750	BOSS SPLINE	2				0.098	0.2156
140	TC220-21780	CIR CLIP EXTERNAL	2				0.006	0.0132
150	TC220-21660	PLATE	1				0.075	0.165
160	01123-60816	BOLT	2				0.01	0.022

REVERSE SHAFT [EXCEPT HST TYPE]

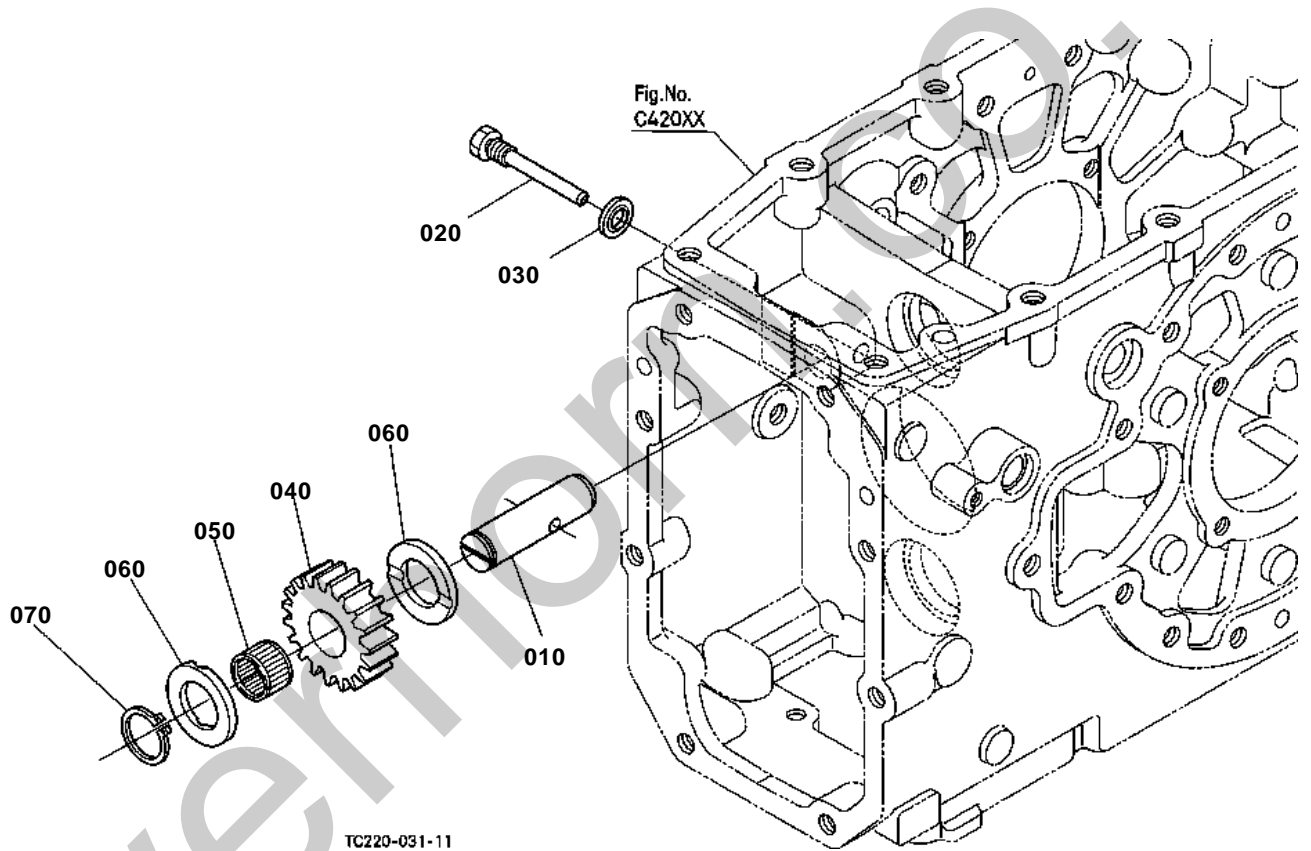



## REVERSE SHAFT [EXCEPT HST TYPE]

↔ Interchangeable; ≠ not interchangeable; ← new for old; → old for new

REF.No	Part No.	Description	Q'ty	S.No.	I/C	REMARKS	Weight (kgf)	Weight (lb)
010	TC220-21950	SHAFT BACK	1				0.176	0.3872
020	TC220-23120	BOLT	1				0.022	0.0484
030	04717-00800	WASHER WITH RUBBER	1				0.001	0.0022
040	TC220-21960	GEAR	1			18T	0.284	0.6248
050	TC220-22030	BEARING NEEDLE	1				0.015	0.033
060	31391-14330	COLLAR THRUST	2				0.007	0.0154
070	04612-00200	CIR CLIP EXTERNAL	1				0.001	0.0022

RANGE GEAR SHAFT [EXCEPT HST TYPE]

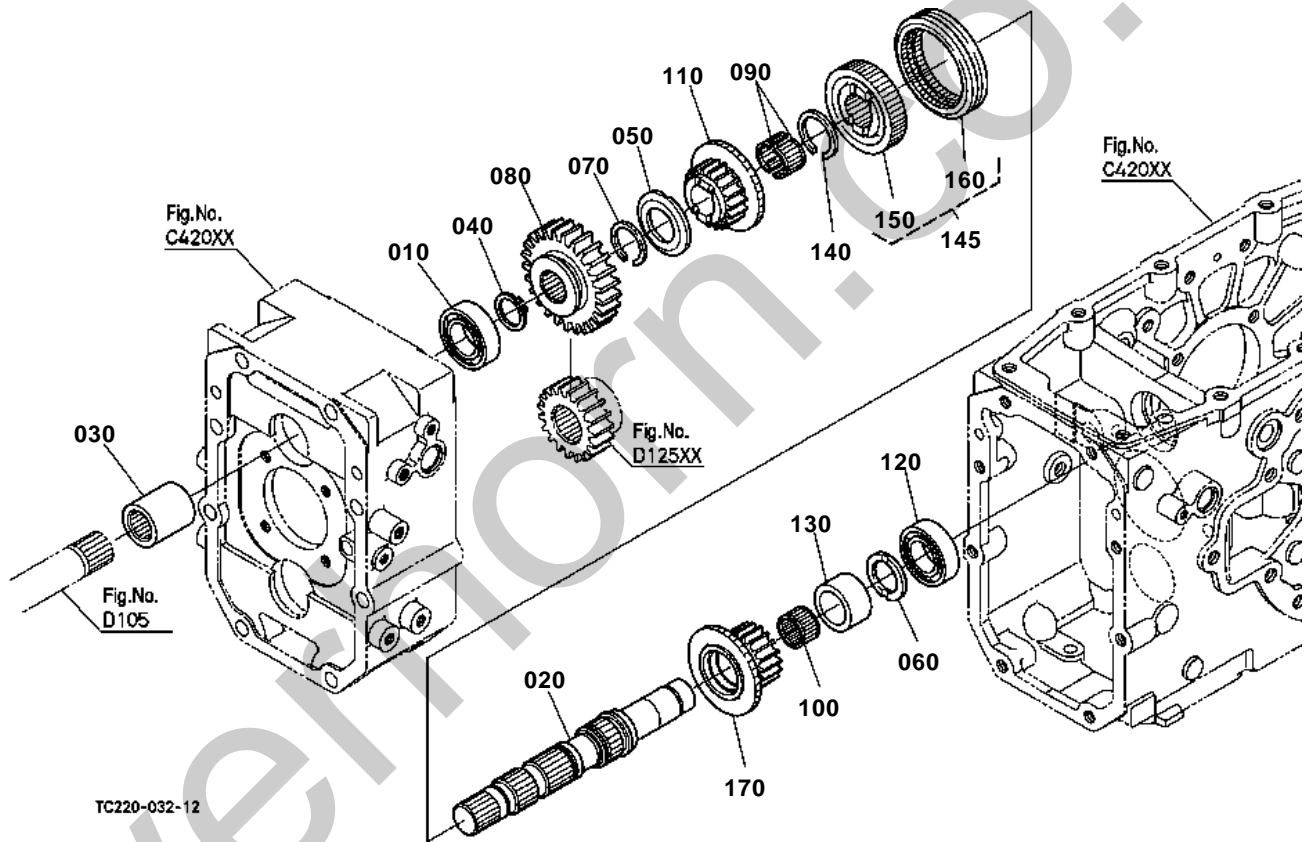

TC220-032-12

OLD PARTS

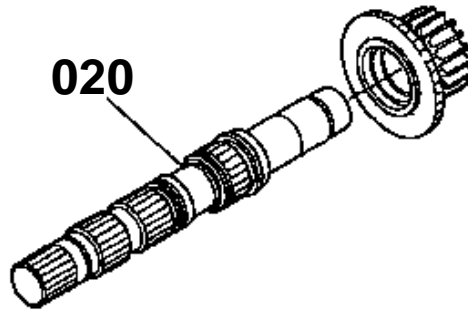

Silverhorn.co.uk

TC227-801-10



# RANGE GEAR SHAFT [EXCEPT HST TYPE]

↔ Interchangeable; ≠ not interchangeable; ← new for old; → old for new

REF.No	Part No.	Description	Q'ty	S.No.	I/C	REMARKS	Weight (kgf)	Weight (lb)
010	67121-56770	BEARING BALL	1				0.127	0.2794
020	TC220-21910	SHAFT RANGE GEAR	1	<=54777			1.08	2.376
020	TC220-21912	SHAFT RANGE GEAR	1	>=54778	-		1.08	2.376
030	37150-21682	COUPLING	1				0.24	0.528
040	37150-21551	CIR CLIP EXTERNAL	1				0.005	0.011
050	T1150-22570	COLLAR THRUST	1				0.024	0.0528
060	67111-14450	COLLAR	1				0.01	0.022
070	37410-14540	CIR-CLIP	1				0.03	0.066
080	TC220-21922	GEAR	1			31T	0.89	1.958
090	T1030-22330	BEARING NEEDLE	1			SET	0.03	0.066
100	T1063-62480	BEARING NEEDLE	1				0.027	0.0594
110	TC220-21930	GEAR	1			18T	0.32	0.704
120	TC220-22140	BEARING BALL	1				0.128	0.2816
130	TC220-21970	COLLAR	1				0.11	0.242
140	T1060-22882	CIR CLIP EXTERNAL	1				0.005	0.011
145	TC220-22820	ASSY SHIFTER	1				0	0
150	TC220-21990	BOSS SPLINE	1				0.505	1.111
160	TA040-22440	SHIFTER	1				0.225	0.495
170	TC220-21940	GEAR	1			17T	0.43	0.946



RANGE GEAR SHAFT [HST TYPE]

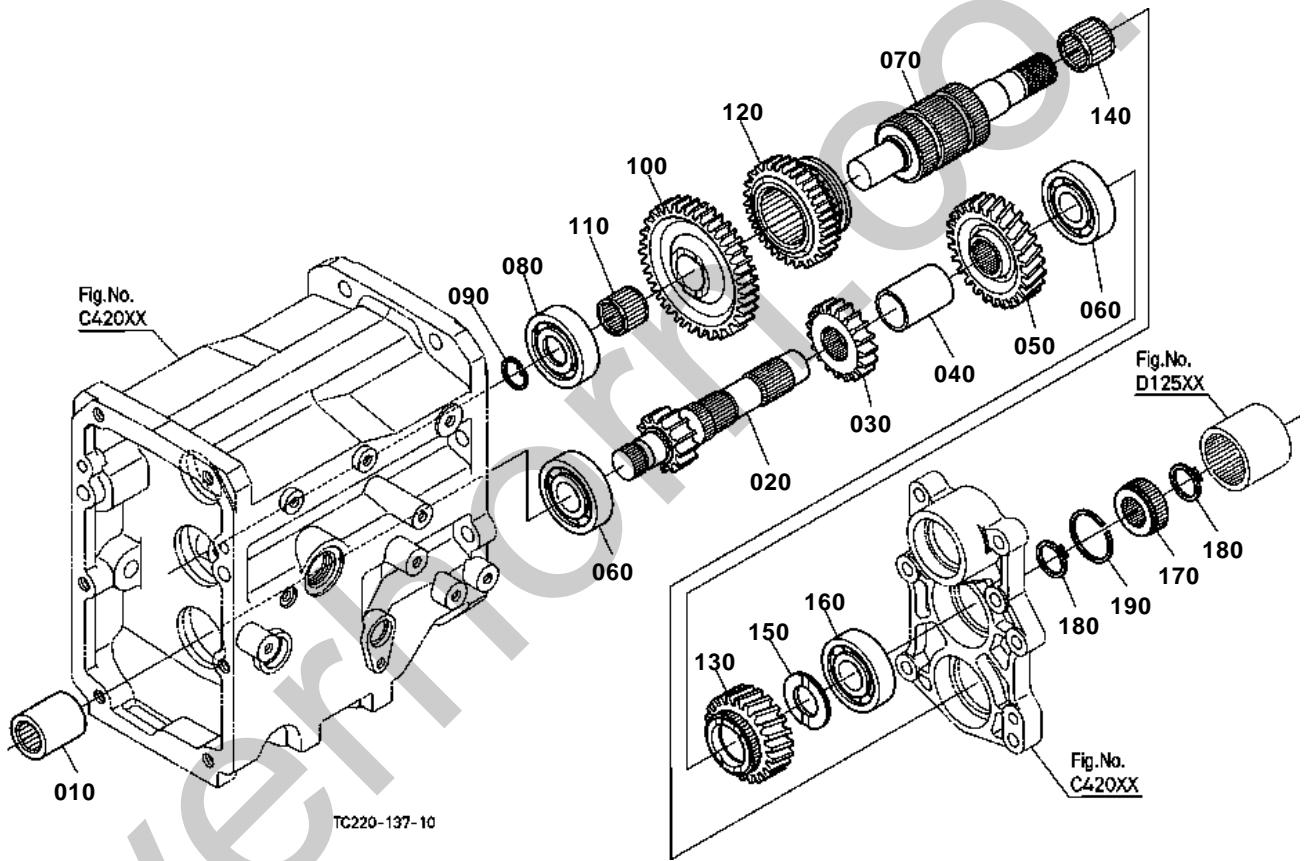

**RANGE GEAR SHAFT [HST TYPE]**

↔ Interchangeable; ≠ not interchangeable; ← new for old; → old for new

REF.No	Part No.	Description	Q'ty	S.No.	I/C	REMARKS	Weight (kgf)	Weight (lb)
010	37150-21682	COUPLING	1				0.24	0.528
020	TC220-52500	GEAR-SHAFT	1			13T	0	0
030	TC220-52520	GEAR	1			19T	0	0
040	TC220-52540	COLLAR	1				0	0
050	TC220-52530	GEAR	1			28T	0.535	1.177
060	TC220-52550	BEARING BALL	2				0	0
070	TC220-52600	SHAFT RANGE GEAR	1				0	0
080	34070-22260	BEARING BALL	1				0.235	0.517
090	04611-00250	CIR CLIP INTERNAL	1				0.001	0.0022
100	TC220-52610	GEAR	1			37T	0	0
110	T1060-22310	BEARING NEEDLE	1				0.025	0.055
120	TC220-52620	GEAR SLIDE	1			31T	0	0
130	TC220-52630	GEAR	1			22T	0	0
140	08822-83327	BEARING NEEDLE	1				0.034	0.0748
150	32420-67662	COLLAR THRUST	1				0.005	0.011
160	TC220-52550	BEARING BALL	1				0	0
170	32430-67760	BOSS SPLINE	1				0.115	0.253
180	04612-00250	CIR CLIP EXTERNAL	2				0.002	0.0044
190	32430-67800	CIR-CLIP	1				0.005	0.011

SPIRAL BEVEL PINION [EXCEPT HST TYPE]

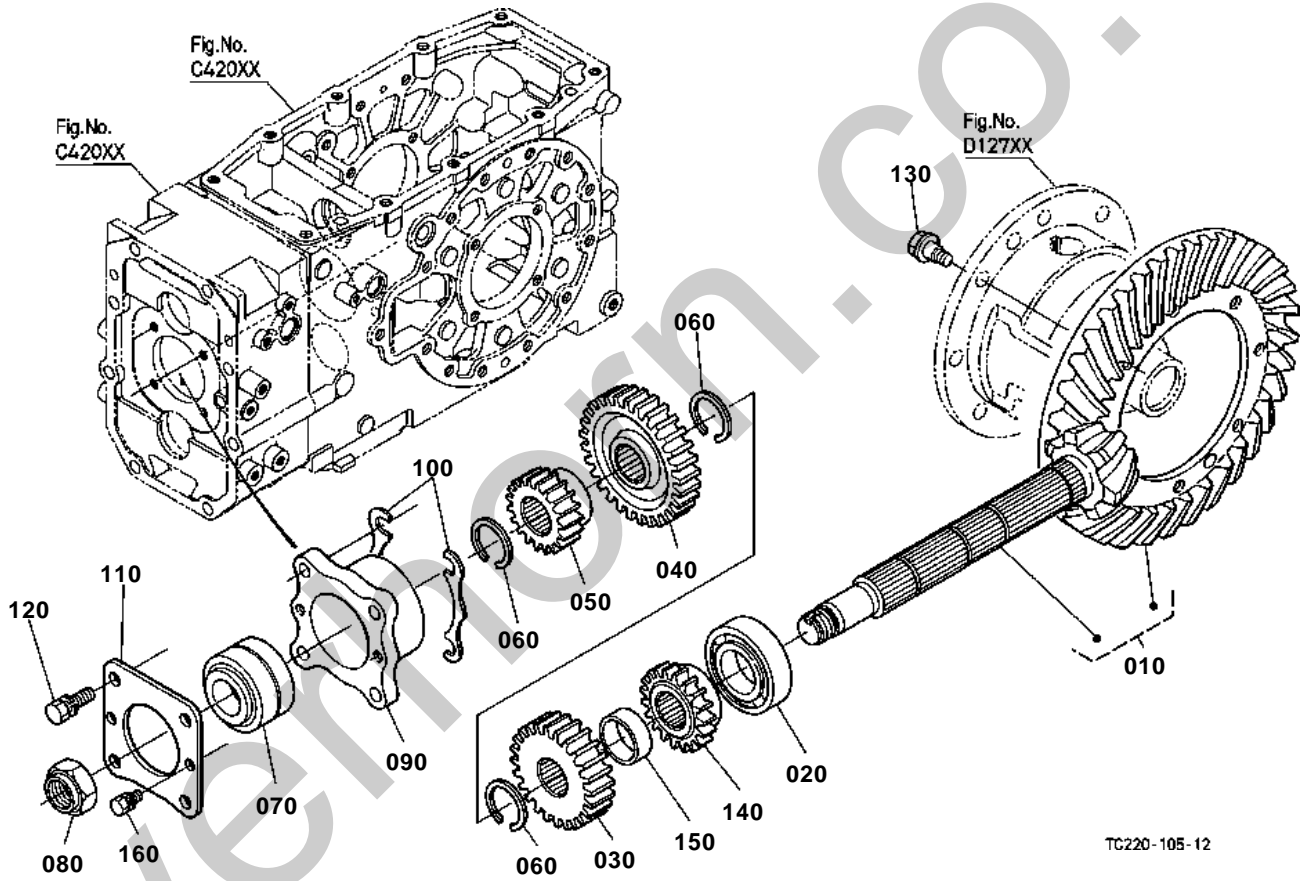

**SPIRAL BEVEL PINION [EXCEPT HST TYPE]**

↔ Interchangeable; ≠ not interchangeable; ← new for old; → old for new

REF.No	Part No.	Description	Q'ty	S.No.	I/C	REMARKS	Weight (kgf)	Weight (lb)
010	TC210-99340	ASSY GEAR BEVEL	1			6-37T	6.4	14.08
020	34070-22740	BEARING ROLLER	1				0.51	1.122
030	TC220-22040	GEAR	1			29T	0.88	1.936
040	TC220-22050	GEAR	1			42T	0.83	1.826
050	TC220-22060	GEAR	1			19T	0.37	0.814
060	T1060-22882	CIR CLIP EXTERNAL	3				0.005	0.011
070	T0330-22200	BEARING TAPER-ROLLER	1				0.575	1.265
080	35260-23252	NUT	1				0.04	0.088
090	37300-22150	CASE BEARING	1				0.56	1.232
100	34150-22610	SHIM	2			0.5mm	0.01	0.022
100	34150-22620	SHIM	4			0.2mm	0.005	0.011
100	34150-22630	SHIM	2			0.1mm	0.005	0.011
110	34150-22170	COVER BEARING	1				0.16	0.352
120	01133-51035	BOLT	4				0.03	0.066
130	37800-43870	BOLT	8				0.026	0.0572
140	TC220-15110	GEAR 4WD	1			18T	0.325	0.715
150	TC220-22010	COLLAR	1				0.042	0.0924
160	01123-60816	BOLT	2	>=55199			0.01	0.022

SPIRAL BEVEL PINION [HST TYPE]

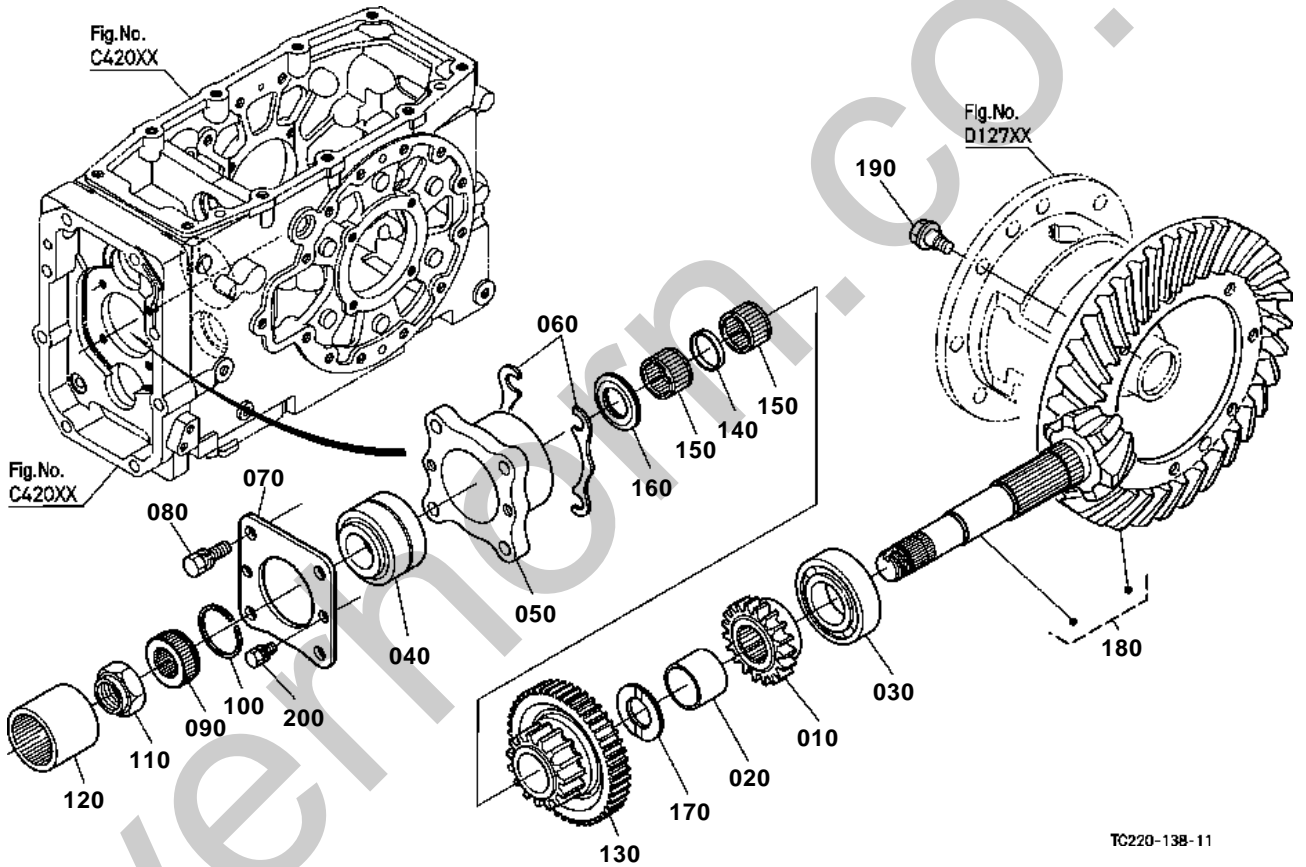

TC220-138-11



## SPIRAL BEVEL PINION [HST TYPE]

↔ Interchangeable; ≠ not interchangeable; ← new for old; → old for new

REF.No	Part No.	Description	Q'ty	S.No.	I/C	REMARKS	Weight (kgf)	Weight (lb)
010	TC220-15110	GEAR 4WD	1			18T	0.325	0.715
020	TC220-53560	COLLAR	1				0	0
030	34070-22740	BEARING ROLLER	1				0.51	1.122
040	T0330-22200	BEARING TAPER-ROLLER	1				0.575	1.265
050	37300-22150	CASE BEARING	1				0.56	1.232
060	34150-22610	SHIM	2			0.5mm	0.01	0.022
060	34150-22620	SHIM	4			0.2mm	0.005	0.011
060	34150-22630	SHIM	2			0.1mm	0.005	0.011
070	34150-22170	COVER BEARING	1				0.16	0.352
080	01133-51035	BOLT	4				0.03	0.066
090	32430-67760	BOSS SPLINE	1				0.115	0.253
100	32430-67800	CIR-CLIP	1				0.005	0.011
110	35260-23252	NUT	1				0.04	0.088
120	32430-67770	COUPLING	1				0.305	0.671
130	TC220-53550	GEAR PTO	1			15-44T	0	0
140	TC220-53570	COLLAR INNER	1				0	0
150	34550-15390	BEARING NEEDLE	2				0.03	0.066
160	32420-67662	COLLAR THRUST	1				0.005	0.011
170	32420-67690	COLLAR THRUST	1				0.02	0.044
180	TC210-99840	ASSY GEAR BEVEL	1			6-37T	0	0
190	37800-43870	BOLT	8				0.026	0.0572
200	01123-60816	BOLT	2	>=55199			0.01	0.022

REAR DIFFERENTIAL

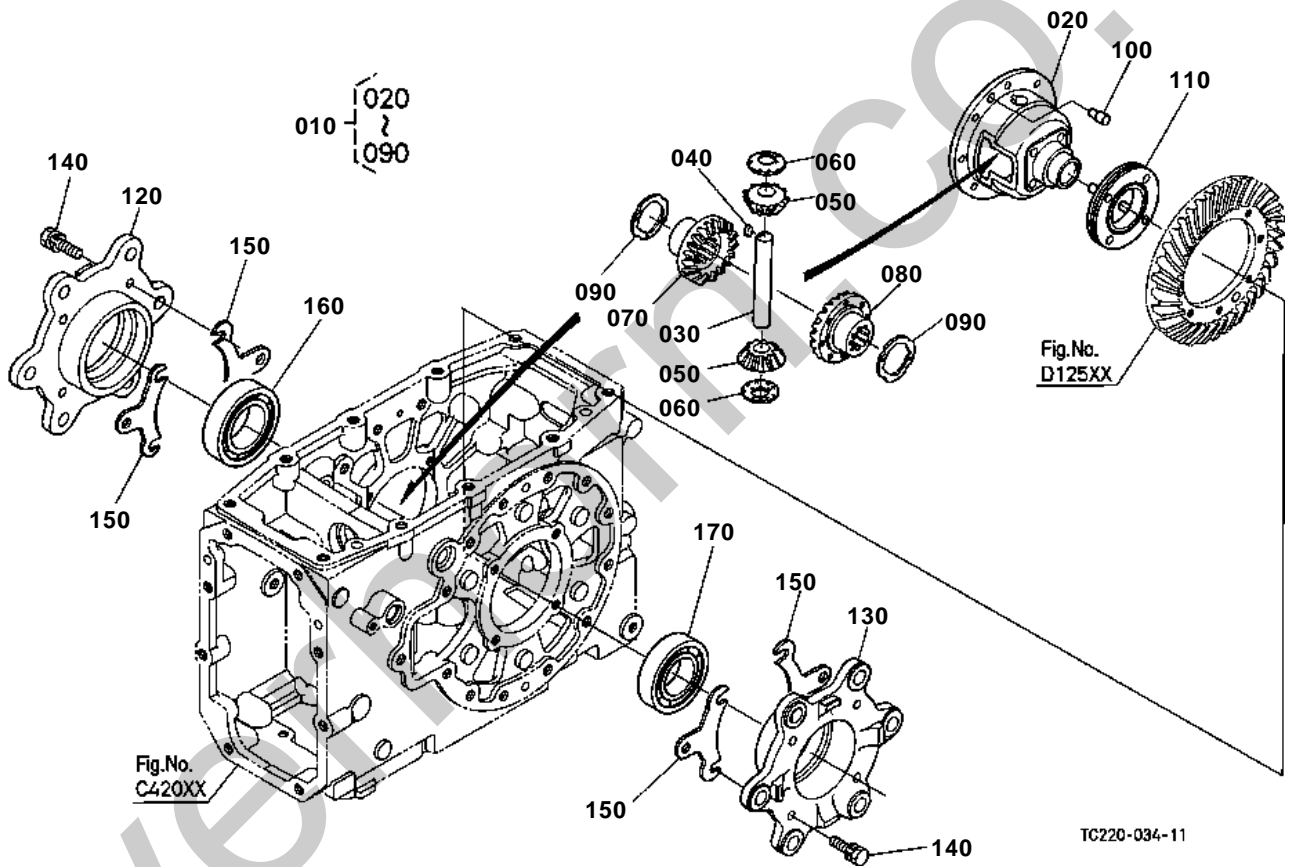

**REAR DIFFERENTIAL**

↔ Interchangeable; ≠ not interchangeable; ← new for old; → old for new

REF.No	Part No.	Description	Q'ty	S.No.	I/C	REMARKS	Weight (kgf)	Weight (lb)
010	31331-26100	ASSY DIFFERENTIAL	1				4.4	9.68
020	31331-26510	CASE DIFFERENTIAL	1				2.7	5.94
030	31331-26340	SHAFT DIFF.PINION	1				0.3	0.66
040	31220-26280	KEY FEATHER	1				0.005	0.011
050	35430-26350	PINION DIFF.	2			12T	0.16	0.352
060	31351-26390	WASHER DIFF.PINION	2				0.012	0.0264
070	32580-43330	GEAR DIFF.SIDE	1			20T	0.49	1.078
080	38180-26440	GEAR DIFF.SIDE LH	1			20T	0.61	1.342
090	31331-26470	WASHER SIDE GEAR	2			1.5mm	0.005	0.011
090	31331-26480	WASHER SIDE GEAR	2			1.6mm	0.017	0.0374
090	31331-26490	WASHER SIDE GEAR	2			1.7mm	0.02	0.044
100	37300-28170	PIN STRAIGHT	2				0.025	0.055
100	T1270-28170	PIN STRAIGHT	2		«		0.025	0.055
110	T1030-26610	SHIFTER DIFF.LOCK	1				0.44	0.968
120	31331-26550	CASE DIFF.BEARING RH	1				1.59	3.498
130	31331-26560	CASE DIFF.BEARING LH	1				1.9	4.18
140	01133-51030	BOLT	8				0.025	0.055
150	37150-26160	SHIM	12			0.2mm	0.005	0.011
150	37150-26170	SHIM	8			0.1mm	0.005	0.011
150	37150-26180	SHIM	4			0.5mm	0.01	0.022
160	TC210-26270	BEARING BALL	1				0.455	1.001
170	TC210-26280	BEARING BALL	1				0.36	0.792



PTO COUNTERSHAFT [EXCEPT HST TYPE]

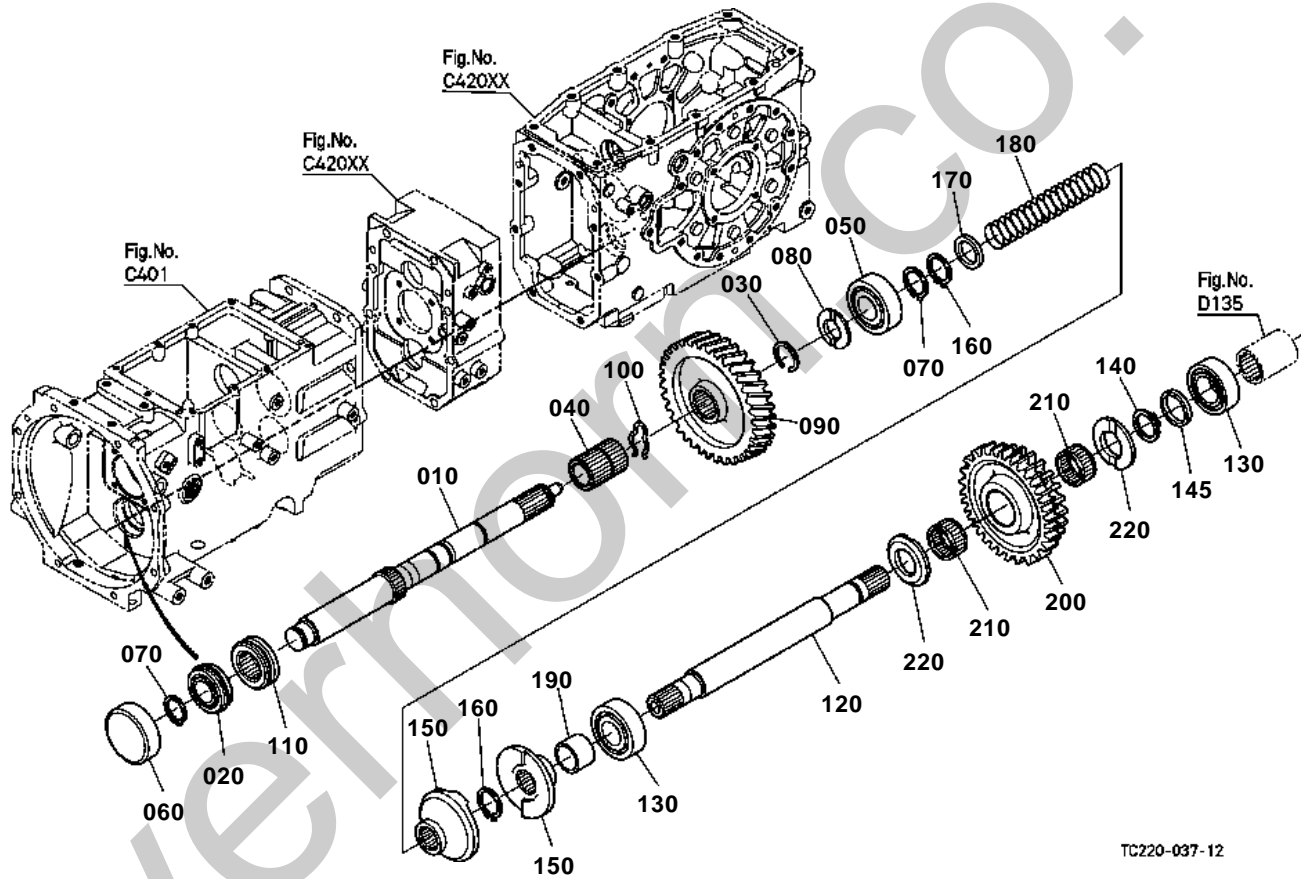

TC220-037-12



## PTO COUNTERSHAFT [EXCEPT HST TYPE]

↔ Interchangeable; ≠ not interchangeable; ← new for old; → old for new

REF.No	Part No.	Description	Q'ty	S.No.	I/C	REMARKS	Weight (kgf)	Weight (lb)
010	TC210-21380	COUNTER SHAFT	1				1.64	3.608
020	TC220-22150	BEARING BALL	1				0.13	0.286
030	37150-21790	CIR-CLIP	1				0.001	0.0022
040	TC210-21450	BOSS SPLINE	1				0.147	0.3234
050	TC220-22140	BEARING BALL	1				0.128	0.2816
060	34150-21650	COVER BEARING	1				0.07	0.154
070	37150-21551	CIR CLIP EXTERNAL	2				0.005	0.011
080	37150-21760	COLLAR THRUST	1				0.017	0.0374
090	37150-21740	GEAR	1			45T	1.08	2.376
100	35340-21782	CIR-CLIP	1				0.007	0.0154
110	TC210-21460	SHIFTER PTO	1				0.156	0.3432
120	TC210-25210	SHAFT DRIVE	1	<=57744			1.31	2.882
120	TC210-25213	SHAFT DRIVE	1	>=57745	1		1.31	2.882
130	TC220-22140	BEARING BALL	2				0.128	0.2816
140	37150-21551	CIR CLIP EXTERNAL	1				0.005	0.011
145	35370-37820	COLLAR	1	>=57745			0.015	0.033
150	35200-25240	CAM CLUTCH	2	<=55198			0	0
150	35200-25244	CAM CLUTCH	2	>=55199	-		0	0
160	37150-21551	CIR CLIP EXTERNAL	2				0.005	0.011
170	34150-21560	WASHER	1				0.01	0.022
180	35200-25230	SPRING ONE-WAY	1				0.075	0.165
190	35200-25250	COLLAR	1				0.04	0.088
200	TC220-15120	GEAR	1			25-34T	0.96	2.112
210	08822-53114	BEARING NEEDLE	2				0.02	0.044
220	38240-21760	COLLAR THRUST	2				0.02	0.044

PTO COUNTERSHAFT [HST TYPE]

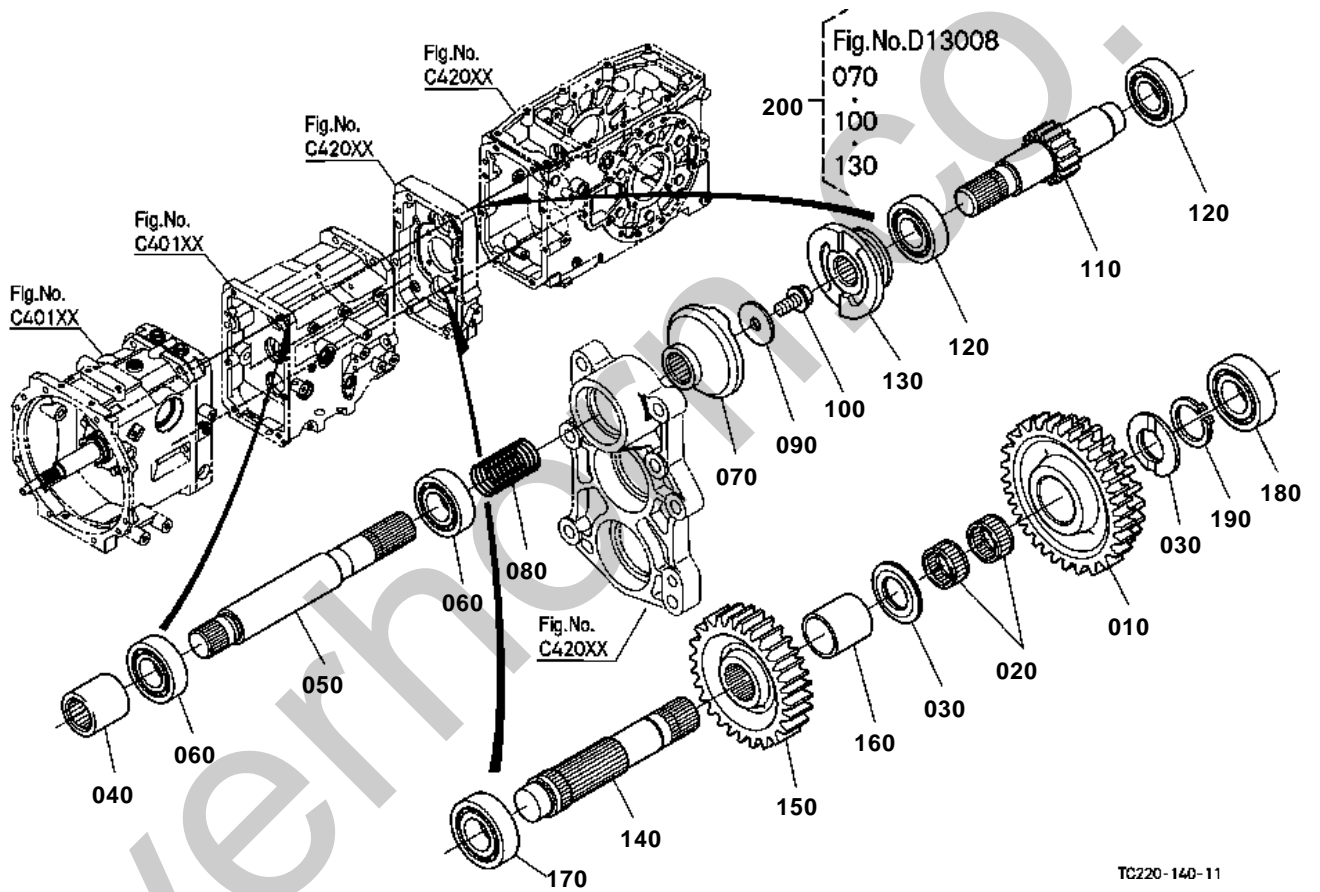

TC220-140-11



## PTO COUNTERSHAFT [HST TYPE]

↔ Interchangeable; ≠ not interchangeable; ← new for old; → old for new

REF.No	Part No.	Description	Q'ty	S.No.	I/C	REMARKS	Weight (kgf)	Weight (lb)
010	TC220-15120	GEAR	1			34-25T	0.96	2.112
020	08822-53114	BEARING NEEDLE	2				0.02	0.044
030	38240-21760	COLLAR THRUST	2				0.02	0.044
040	37150-21682	COUPLING	1				0.24	0.528
050	TC220-53250	COUNTERSHAFT PTO	1				0	0
060	TC220-53520	BEARING BALL	2				0	0
070	35200-25240	CAM CLUTCH	1	<=55198		NOT SALE ORDER BY REF.No.200	0	0
070	35200-25244	CAM CLUTCH	1	>=55199	→		0	0
080	TA240-51470	SPRING	1				0.058	0.1276
090	41330-76120	WASHER	1				0.025	0.055
100	TA140-23950	BOLT	1				0.022	0.0484
110	TC220-53500	GEAR-SHAFT PTO	1			16T	0	0
120	TC220-53520	BEARING BALL	2				0	0
130	TC220-53410	CAM PTO CLUTCH	1	<=55198		NOT SALE ORDER BY REF.No.200	0	0
130	TC220-53412	CAM PTO CLUTCH	1	>=55199	→		0	0
140	TC220-53680	SHAFT DRIVE	1			NOT SALE	0	0
140	TC220-53683	SHAFT DRIVE	1		→		0	0
150	TC220-53610	GEAR PTO	1			27T	0	0
160	TC220-53620	COLLAR PTO DRIVE	1				0	0
170	37410-57190	BEARING BALL	1				0.14	0.308
180	TC220-22140	BEARING BALL	1				0.128	0.2816
190	37150-21551	CIR CLIP EXTERNAL	1				0.005	0.011
200	TC220-99980	KIT CAM	1	<=55198		OPTION	1.06	2.332

PTO COUNTERSHAFT [HST TYPE] [OLD TYPE]

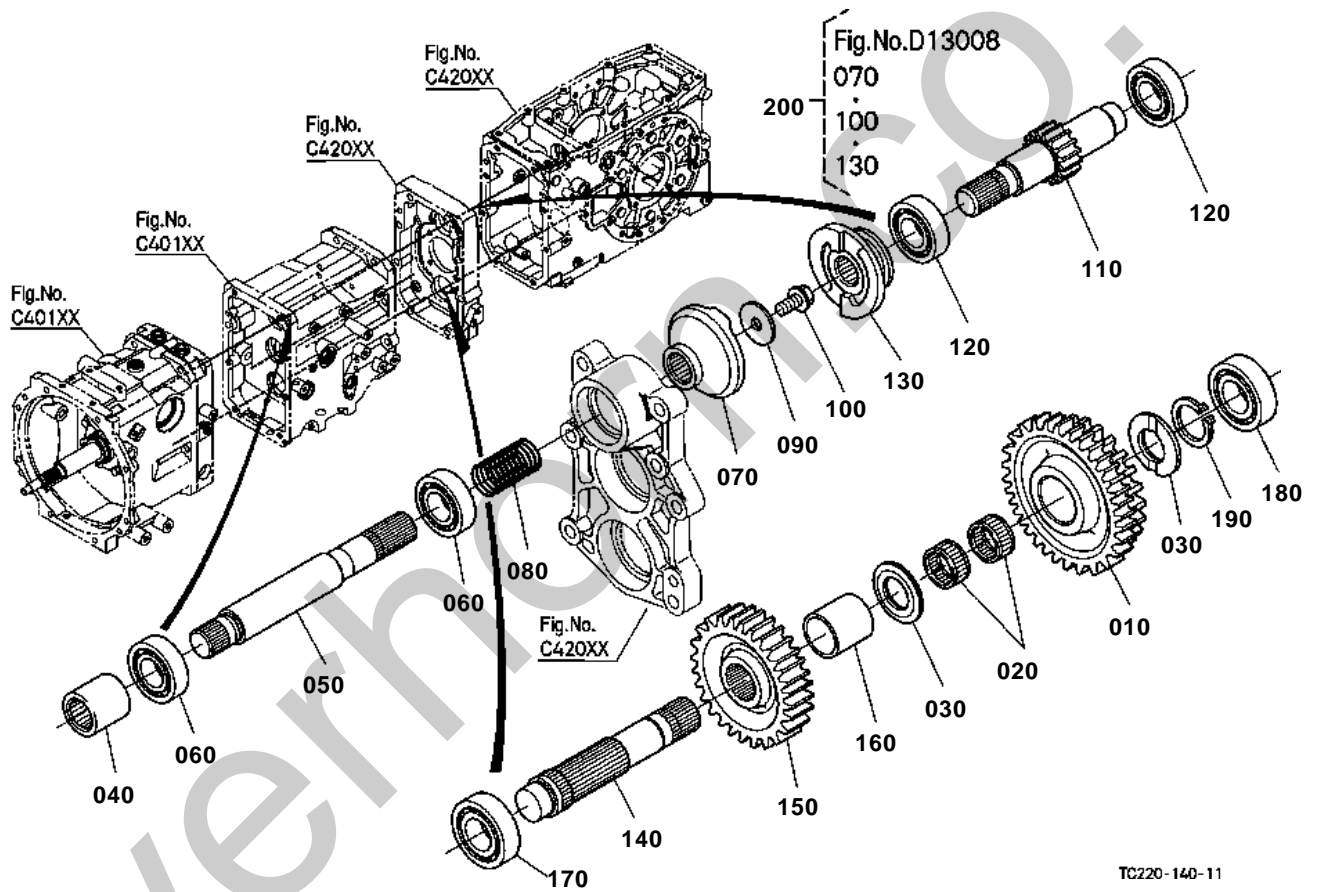

TC220-140-11

**PTO COUNTERSHAFT [HST TYPE] [OLD TYPE]**

S.No.;&lt;=57744

↔ Interchangeable; ≠ not interchangeable; ← new for old; → old for new

REF.No	Part No.	Description	Q'ty	S.No.	I/C	REMARKS	Weight (kgf)	Weight (lb)
010	TC220-15120	GEAR	1			34-25T	0.96	2.112
020	08822-53114	BEARING NEEDLE	2				0.02	0.044
030	38240-21760	COLLAR THRUST	2				0.02	0.044
040	37150-21682	COUPLING	1				0.24	0.528
050	TC220-53250	COUNTERSHAFT PTO	1				0	0
060	TC220-53520	BEARING BALL	2				0	0
070	35200-25240	CAM CLUTCH	1	<=55198		ORDER BY REF.No.200	0	0
070	35200-25244	CAM CLUTCH	1	>=55199	-	ORDER BY REF.No.200	0	0
080	TA240-51470	SPRING	1				0.058	0.1276
090	41330-76120	WASHER	1				0.025	0.055
100	TA140-23950	BOLT	1				0.022	0.0484
110	TC220-53500	GEAR-SHAFT PTO	1			16T	0	0
120	TC220-53520	BEARING BALL	2				0	0
130	TC220-53410	CAM PTO CLUTCH	1	<=55198		ORDER BY REF.No.200	0	0
130	TC220-53412	CAM PTO CLUTCH	1	>=55199	-	ORDER BY REF.No.200	0	0
140	TC220-53680	SHAFT DRIVE	1	<=56116			0	0
140	TC220-53683	SHAFT DRIVE	1	>=56117	-		0	0
150	TC220-53610	GEAR PTO	1			27T	0	0
160	TC220-53620	COLLAR PTO DRIVE	1				0	0
170	37410-57190	BEARING BALL	1				0.14	0.308
180	TC220-22140	BEARING BALL	1				0.128	0.2816
190	37150-21551	CIR CLIP EXTERNAL	1				0.005	0.011
200	TC220-99990	KIT CAM	1	<=57744		OPTION	0	0

PTO COUNTERSHAFT [HST TYPE] [NEW TYPE]

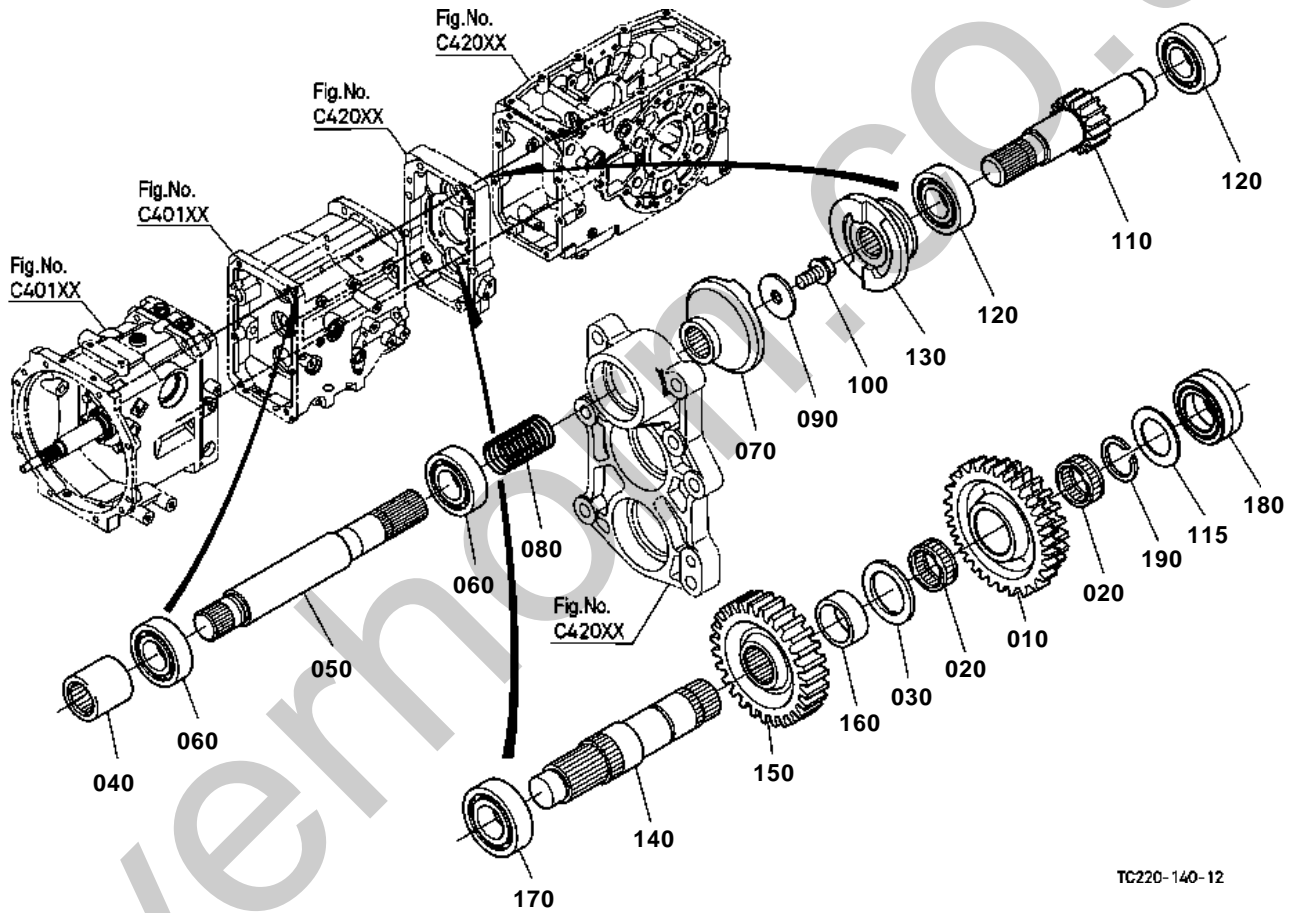

TC220-140-12

**PTO COUNTERSHAFT [HST TYPE] [NEW TYPE]**

S.No.;&gt;=57745

↔ Interchangeable; ≠ not interchangeable; ← new for old; → old for new

REF.No	Part No.	Description	Q'ty	S.No.	I/C	REMARKS	Weight (kgf)	Weight (lb)
010	TC220-15150	GEAR	1			34-25T	0	0
020	TC220-15160	BEARING NEEDLE	2				0	0
030	38430-25233	COLLAR THRUST	1				0.02	0.044
040	37150-21682	COUPLING	1				0.24	0.528
050	TC220-53250	COUNTERSHAFT PTO	1				0	0
060	TC220-53520	BEARING BALL	2				0	0
070	TC220-53450	CAM PTO CLUTCH	1				0	0
080	TA240-51470	SPRING	1				0.058	0.1276
090	41330-76120	WASHER	1				0.025	0.055
100	TA140-23950	BOLT	1				0.022	0.0484
110	TC220-53500	GEAR-SHAFT PTO	1			16T	0	0
115	TC220-23360	COLLAR THRUST	1				0	0
120	TC220-53520	BEARING BALL	2				0	0
130	TC220-53440	CAM PTO CLUTCH	1				0	0
140	TC220-53684	SHAFT DRIVE	1				0.64	1.408
150	TC220-53612	GEAR PTO	1			27T	0.85	1.87
160	TC220-53622	COLLAR PTO DRIVE	1				0.075	0.165
170	37410-57190	BEARING BALL	1				0.14	0.308
180	TC220-15180	BEARING ROLLER	1				0	0
190	37410-15280	CIR-CLIP	1				0.005	0.011



PTO SHAFT

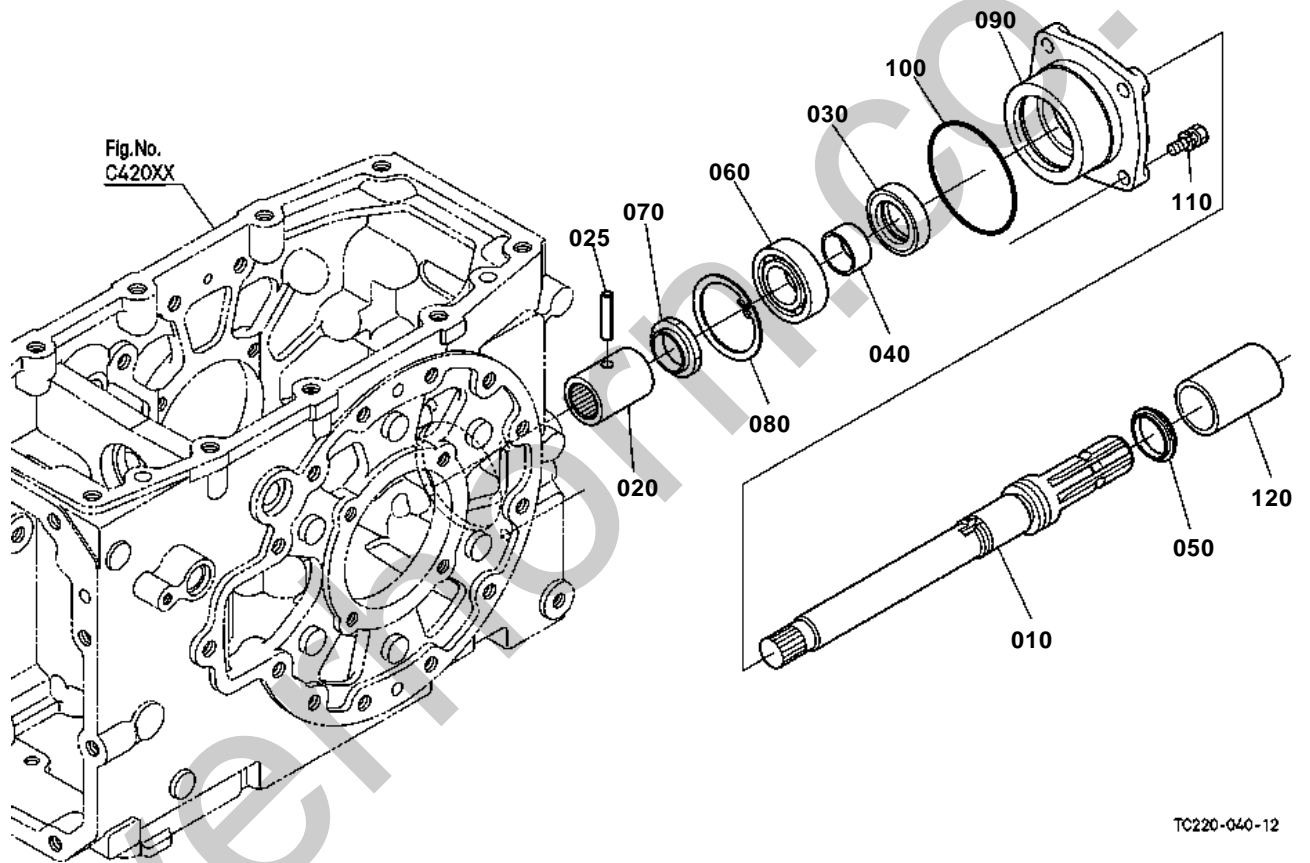

OLD PARTS

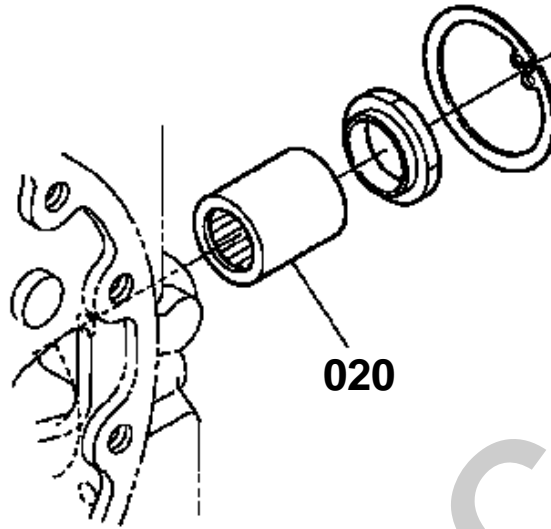

Silverhorn.CO.UK

TC220-853-10



PTO SHAFT

↔ Interchangeable; ≠ not interchangeable; ← new for old; → old for new

REF.No	Part No.	Description	Q'ty	S.No.	I/C	REMARKS	Weight (kgf)	Weight (lb)
010	32420-25313	SHAFT PTO	1				1.94	4.268
020	37150-21682	COUPLING	1	<=57744			0.24	0.528
020	TC220-21680	COUPLING	1	>=57745	1		0	0
025	05411-00636	PIN SPRING	1	>=57745			0.005	0.011
030	37150-25360	SEAL OIL	1				0.025	0.055
040	37300-25350	COLLAR OIL SEAL	1				0.032	0.0704
050	38240-25370	SLINGER	1				0.004	0.0088
060	08101-06206	BEARING BALL	1				0.196	0.4312
070	34150-25320	NUT	1				0.03	0.066
080	04611-00620	CIR CLIP INTERNAL	1				0.011	0.0242
090	37150-25410	CASE BEARING	1				1.02	2.244
090	37150-25414	CASE BEARING	1	<=53881	<<	NOT SALE	1.02	2.244
090	37150-25415	CASE BEARING	1	>=53882	→		1.02	2.244
100	04811-50800	O RING	1				0.003	0.0066
110	01123-50820	BOLT	4				0.011	0.0242
120	31220-25820	CAP	1				0.055	0.121

MAIN GEAR SHIFT FORK [EXCEPT HST TYPE]

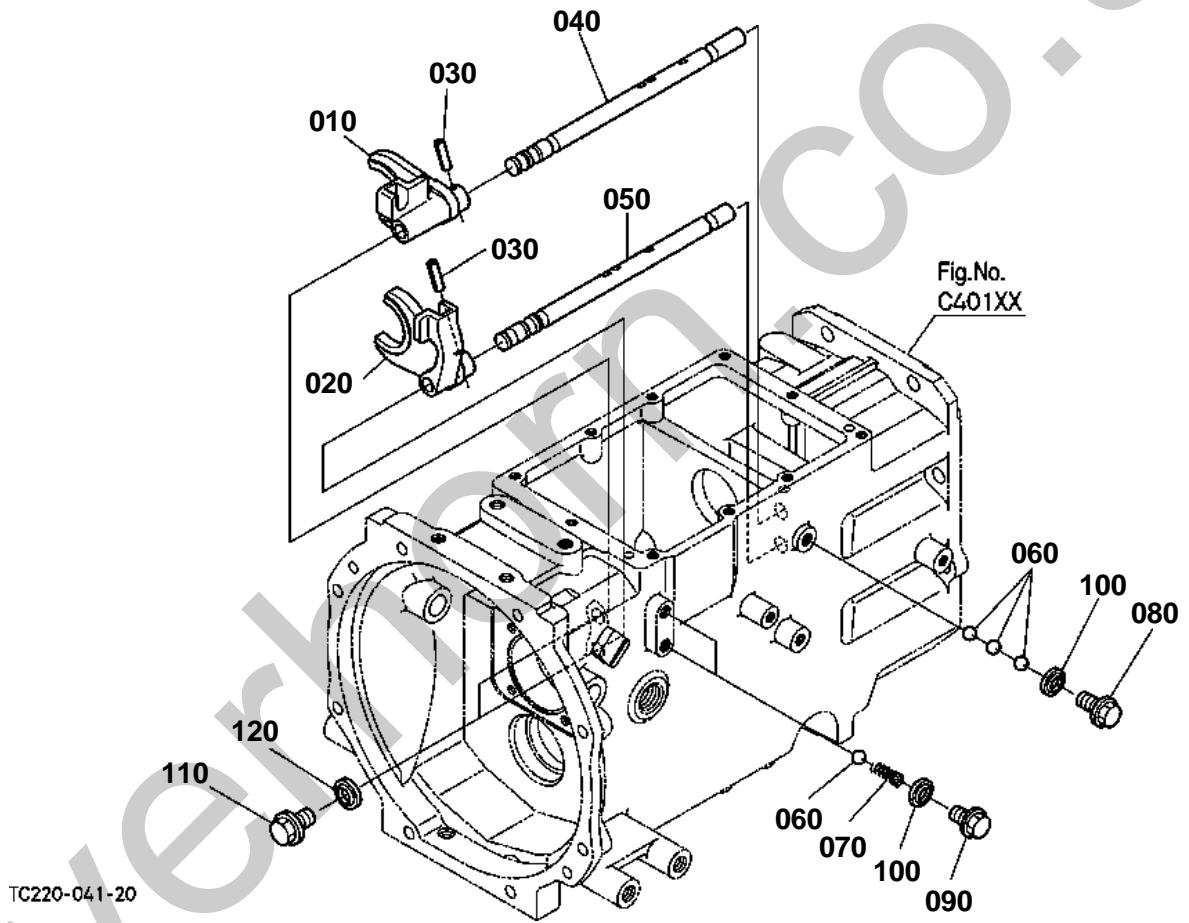



# MAIN GEAR SHIFT FORK [EXCEPT HST TYPE]

↔ Interchangeable; ≠ not interchangeable; ← new for old; → old for new

REF.No	Part No.	Description	Q'ty	S.No.	I/C	REMARKS	Weight (kgf)	Weight (lb)
010	TC220-23510	FORK MAIN SHIFT	1				0.42	0.924
020	TC220-23520	FORK MAIN SHIFT	1				0.435	0.957
030	05411-00522	PIN SPRING	2				0.002	0.0044
040	TC220-23540	ROD FORK	1				0.175	0.385
050	TC220-23550	ROD FORK	1				0.175	0.385
060	07715-01605	BALL	5				0.003	0.0066
070	62231-18530	SPRING	2				0.01	0.022
080	01774-51025	BOLT FLANGE	1				0.02	0.044
090	01774-51010	BOLT FLANGE	2				0.08	0.176
100	04717-01000	WASHER WITH RUBBER	3				0.001	0.0022
110	06331-45014	PLUG	2				0.03	0.066
120	04717-01400	WASHER WITH RUBBER	2				0.002	0.0044

RANGE GEAR SHIFT FORK [EXCEPT HST TYPE]

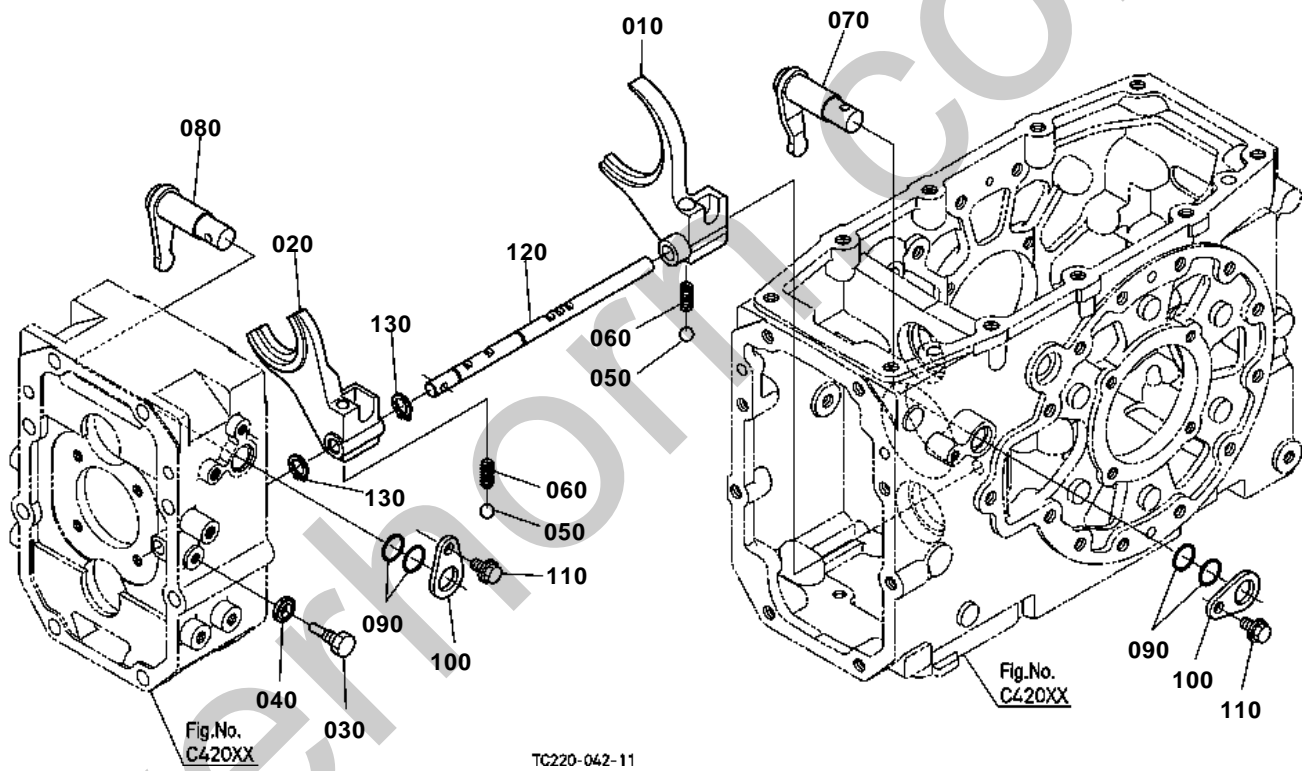

## OLD PARTS

S.No. ; A :  $\leq 10093$   
          , B :  $\leq 50333$   
          , C :  $\leq 10051$   
          , D :  $\leq 50537$

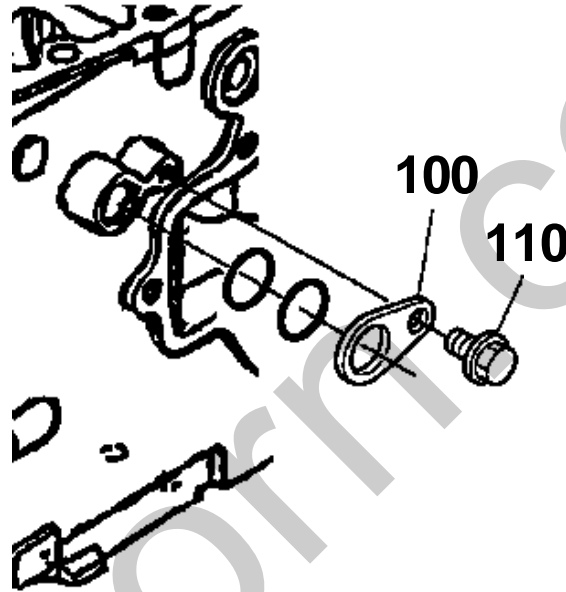

TC220-832-10



# RANGE GEAR SHIFT FORK [EXCEPT HST TYPE]

↔ Interchangeable; ≠ not interchangeable; ← new for old; → old for new

REF.No	Part No.	Description	Q'ty	S.No.	I/C	REMARKS	Weight (kgf)	Weight (lb)
010	TC220-24110	FORK SHIFT	1				0.525	1.155
020	TC220-24120	FORK SHAFT	1	<=50333			0	0
020	TC220-24123	FORK SHAFT	1	>=50334	-		0.475	1.045
020	TC220-24124	FORK SHAFT	1	>=50685	-		0	0
030	37150-23120	SCREW SET	1				0.02	0.044
040	04717-00800	WASHER WITH RUBBER	1				0.001	0.0022
050	07715-01605	BALL	2				0.003	0.0066
060	62231-18530	SPRING	2				0.01	0.022
070	TC220-24420	ARM SHIFT	1				0.215	0.473
080	34070-24422	ARM SHIFT	1				0.21	0.462
090	04816-00200	O RING	4				0.003	0.0066
100	34070-24350	STOPPER	2				0.02	0.044
110	01754-50812	BOLT FLANGE	2				0.01	0.022
120	TC220-24130	ROD FORK	1				0.2	0.44
130	04612-00120	CIR CLIP EXTERNAL	2				0.001	0.0022



RANGE GEAR SHIFT FORK [HST TYPE]

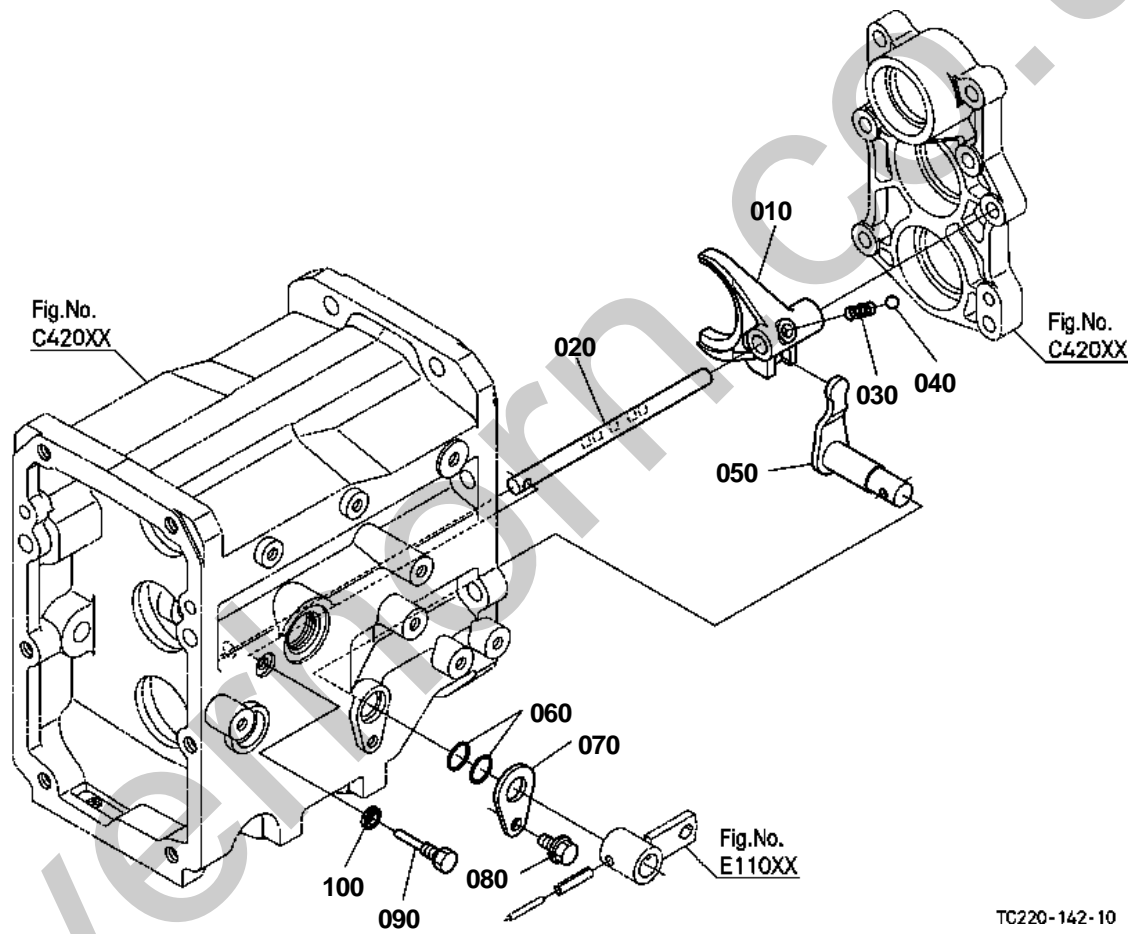

TC220-142-10



# RANGE GEAR SHIFT FORK [HST TYPE]

↔ Interchangeable; ≠ not interchangeable; ← new for old; → old for new

REF.No	Part No.	Description	Q'ty	S.No.	I/C	REMARKS	Weight (kgf)	Weight (lb)
010	TC220-54500	FORK RANGE SHIFT	1				0	0
020	TC220-54410	ROD RANGE SHIFT	1				0	0
030	62231-18530	SPRING	1				0.01	0.022
040	07715-01605	BALL	1				0.003	0.0066
050	TA040-24422	ARM RANGE SHIFT	1				0.21	0.462
060	04816-00200	O RING	2				0.003	0.0066
070	34070-24350	STOPPER	1				0.02	0.044
080	01754-50812	BOLT FLANGE	1				0.01	0.022
090	37150-23120	SCREW SET	1				0.02	0.044
100	04717-00800	WASHER WITH RUBBER	1				0.001	0.0022

PTO GEAR SHIFT FORK [EXCEPT HST TYPE]

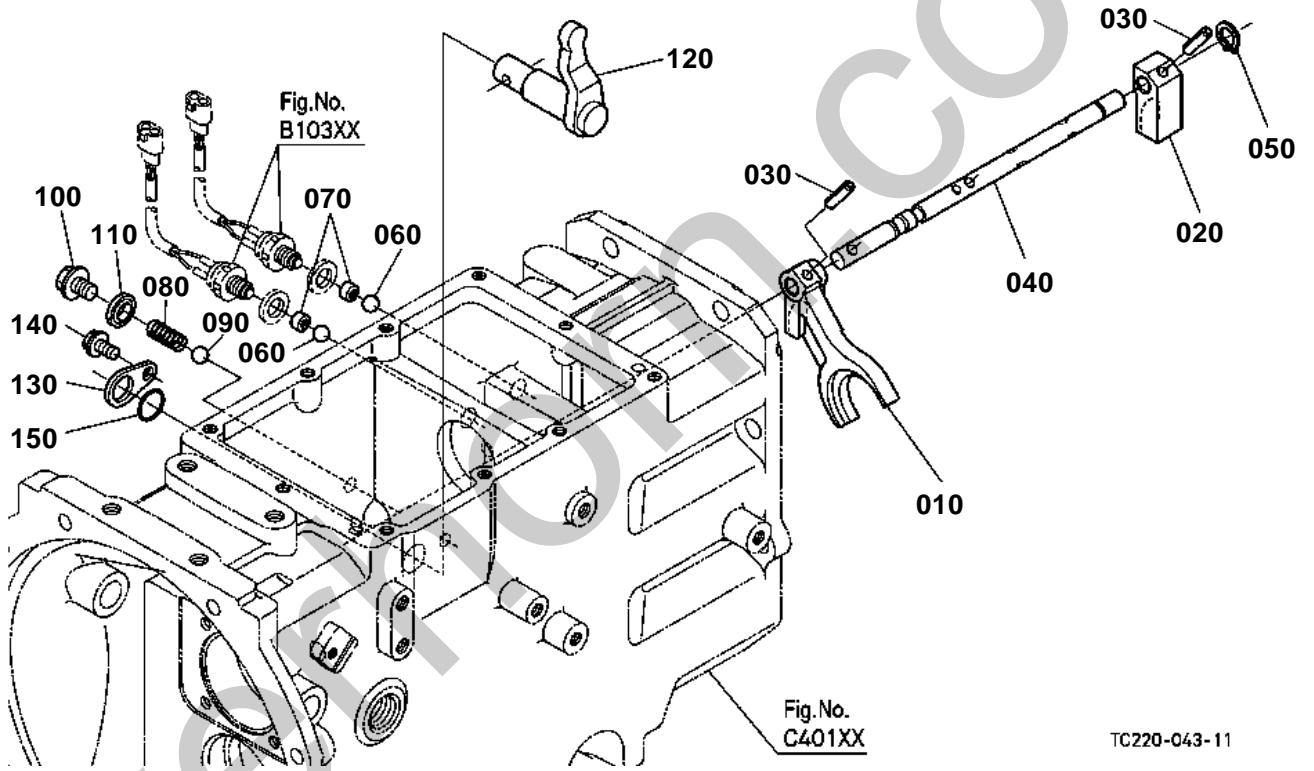

TC220-043-11



# PTO GEAR SHIFT FORK [EXCEPT HST TYPE]

↔ Interchangeable; ≠ not interchangeable; ← new for old; → old for new

REF.No	Part No.	Description	Q'ty	S.No.	I/C	REMARKS	Weight (kgf)	Weight (lb)
010	TC220-24610	FORK PTO SHIFT	1				0.25	0.55
020	TC210-24620	ARM SHIFT	1				0.13	0.286
030	05411-00522	PIN SPRING	2				0.002	0.0044
040	TC220-24630	ROD PTO FORK	1				0.21	0.462
050	04612-00120	CIR CLIP EXTERNAL	1				0.001	0.0022
060	07715-01605	BALL	2				0.003	0.0066
070	TC220-24670	SPACER	2				0	0
080	32530-23730	SPRING	1				0.001	0.0022
090	07715-01605	BALL	1				0.003	0.0066
100	01774-51010	BOLT FLANGE	1				0.08	0.176
110	04717-01000	WASHER WITH RUBBER	1				0.001	0.0022
120	TA040-24422	ARM RANGE SHIFT	1				0.21	0.462
130	34070-24350	STOPPER	1				0.02	0.044
140	01754-50812	BOLT FLANGE	1				0.01	0.022
150	04816-00200	O RING	1				0.003	0.0066

DIFFERENTIAL LOCK SHIFT FORK [EXCEPT HST TYPE]

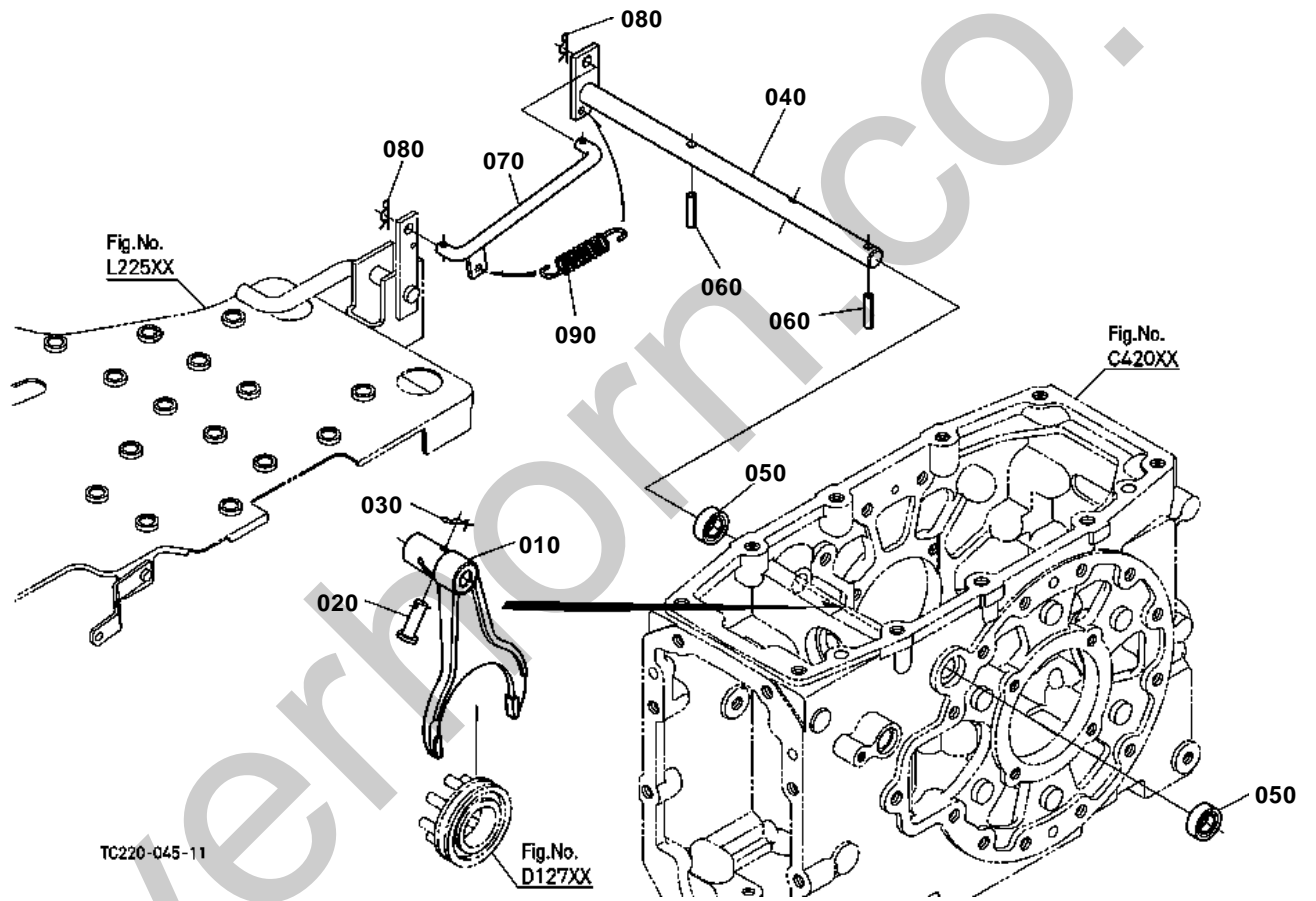



## DIFFERENTIAL LOCK SHIFT FORK [EXCEPT HST TYPE]

↔ Interchangeable; ≠ not interchangeable; ← new for old; → old for new

REF.No	Part No.	Description	Q'ty	S.No.	I/C	REMARKS	Weight (kgf)	Weight (lb)
010	31351-26632	FORK DIFF.LOCK SHIFT	1				0.465	1.023
020	31351-26620	PIN JOINT	1				0.008	0.0176
030	50080-34110	PIN SNAP	1				0.001	0.0022
040	TC220-28400	SHAFT FORK	1				0.54	1.188
050	09500-16287	SEAL OIL	2				0.01	0.022
060	05411-00635	PIN SPRING	2				0.005	0.011
070	T0070-28414	ROD DIFF.LOCK	1				0.08	0.176
080	05515-60800	PIN SNAP	2				0.002	0.0044
090	37150-15840	SPRING	1				0.06	0.132

DIFFERENTIAL LOCK SHIFT FORK [HST TYPE]

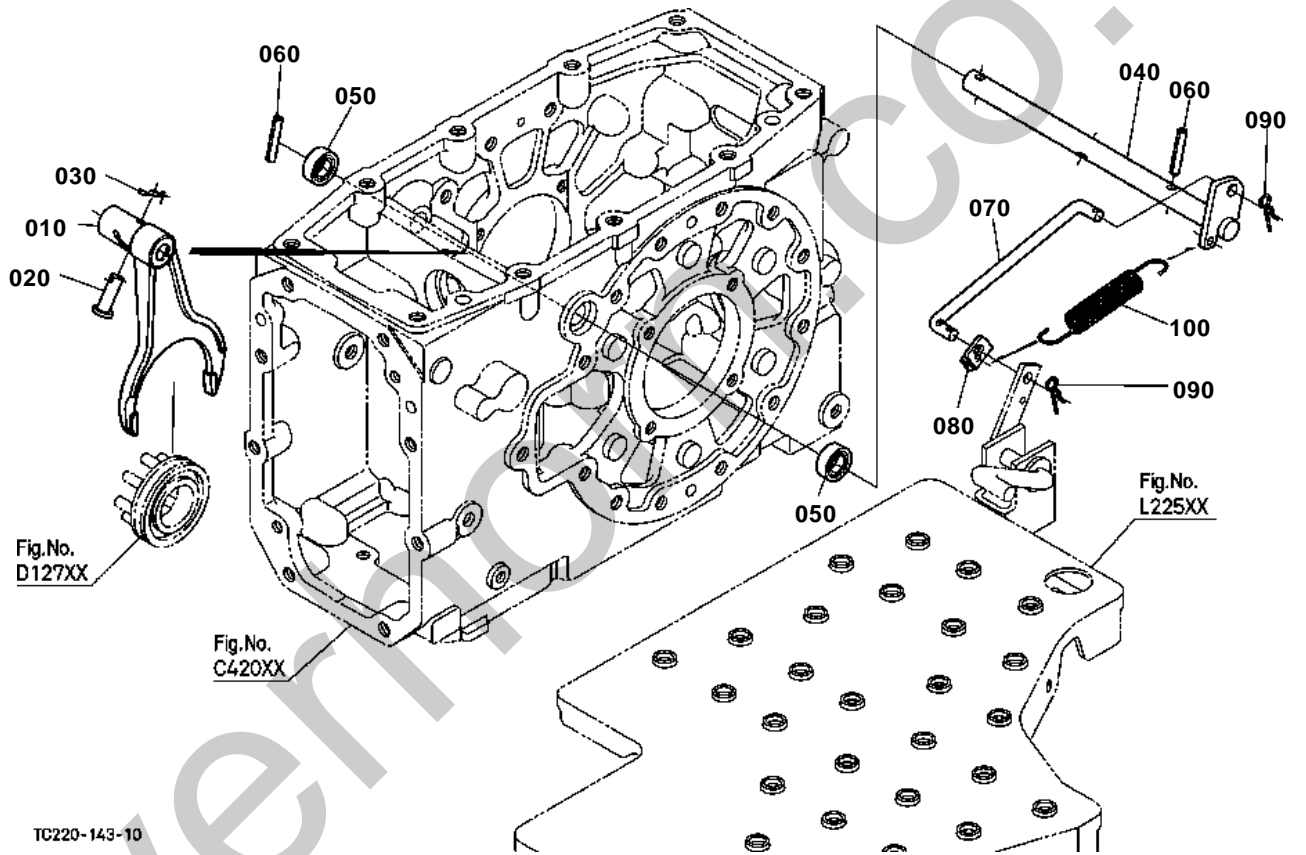

TC220-143-10



# DIFFERENTIAL LOCK SHIFT FORK [HST TYPE]

↔ Interchangeable; ≠ not interchangeable; ← new for old; → old for new

REF.No	Part No.	Description	Q'ty	S.No.	I/C	REMARKS	Weight (kgf)	Weight (lb)
010	31351-26632	FORK DIFF.LOCK SHIFT	1				0.465	1.023
020	31351-26620	PIN JOINT	1				0.008	0.0176
030	50080-34110	PIN SNAP	1				0.001	0.0022
040	TC220-52800	SHAFT FORK	1				0	0
050	09500-16287	SEAL OIL	2				0.01	0.022
060	05411-00635	PIN SPRING	2				0.005	0.011
070	TC220-52810	ROD DIFF.LOCK	1				0	0
080	TC220-52820	PLATE DIFF.LOCK	1				0	0
090	05515-60800	PIN SNAP	2				0.002	0.0044
100	37150-15840	SPRING	1				0.06	0.132



MAIN GEAR SHIFT LEVER [EXCEPT HST TYPE]

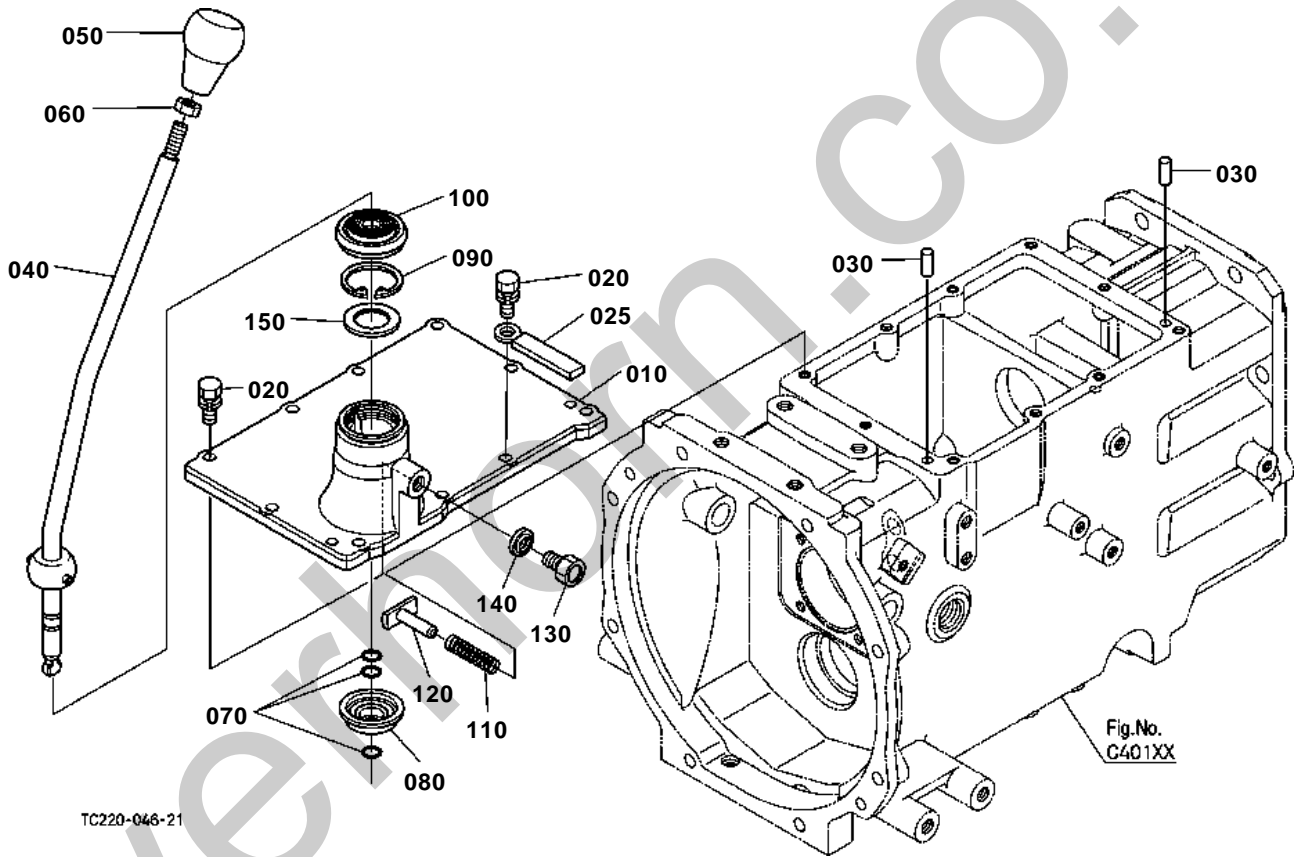



# MAIN GEAR SHIFT LEVER [EXCEPT HST TYPE]

↔ Interchangeable; ≠ not interchangeable; ← new for old; → old for new

REF.No	Part No.	Description	Q'ty	S.No.	I/C	REMARKS	Weight (kgf)	Weight (lb)
010	TC220-23710	COVER CLUTCH HOUSING	1				3.3	7.26
020	01123-50825	BOLT	10				0.013	0.0286
025	13824-67590	CLAMP CORD	1	>=54356			0.002	0.0044
030	05012-00814	PIN STRAIGHT	2				0.006	0.0132
040	TC220-23810	LEVER MAIN SHIFT	1				0.58	1.276
050	TC050-49850	GRIP MAIN SHIFT	1				0.088	0.1936
060	02116-50100	NUT	1				0.004	0.0088
070	04817-00120	O RING	3				0.001	0.0022
080	T0270-23870	SHIELD	1				0.018	0.0396
090	04611-00420	CIR CLIP INTERNAL	1				0.006	0.0132
100	T0270-24970	SHIELD	1				0.015	0.033
110	T0070-24760	SPRING PTO SHIFT	1				0.005	0.011
120	T0070-24810	POPPET PTO SHIFT	1				0.02	0.044
130	T0070-24820	PLUG PTO SHIFT	1				0.015	0.033
140	04717-01200	WASHER WITH RUBBER	1				0.002	0.0044
150	TC030-24782	COLLAR MAIN SHIFT	1				0.016	0.0352

CRUISE CONTROL LEVER [HST TYPE]

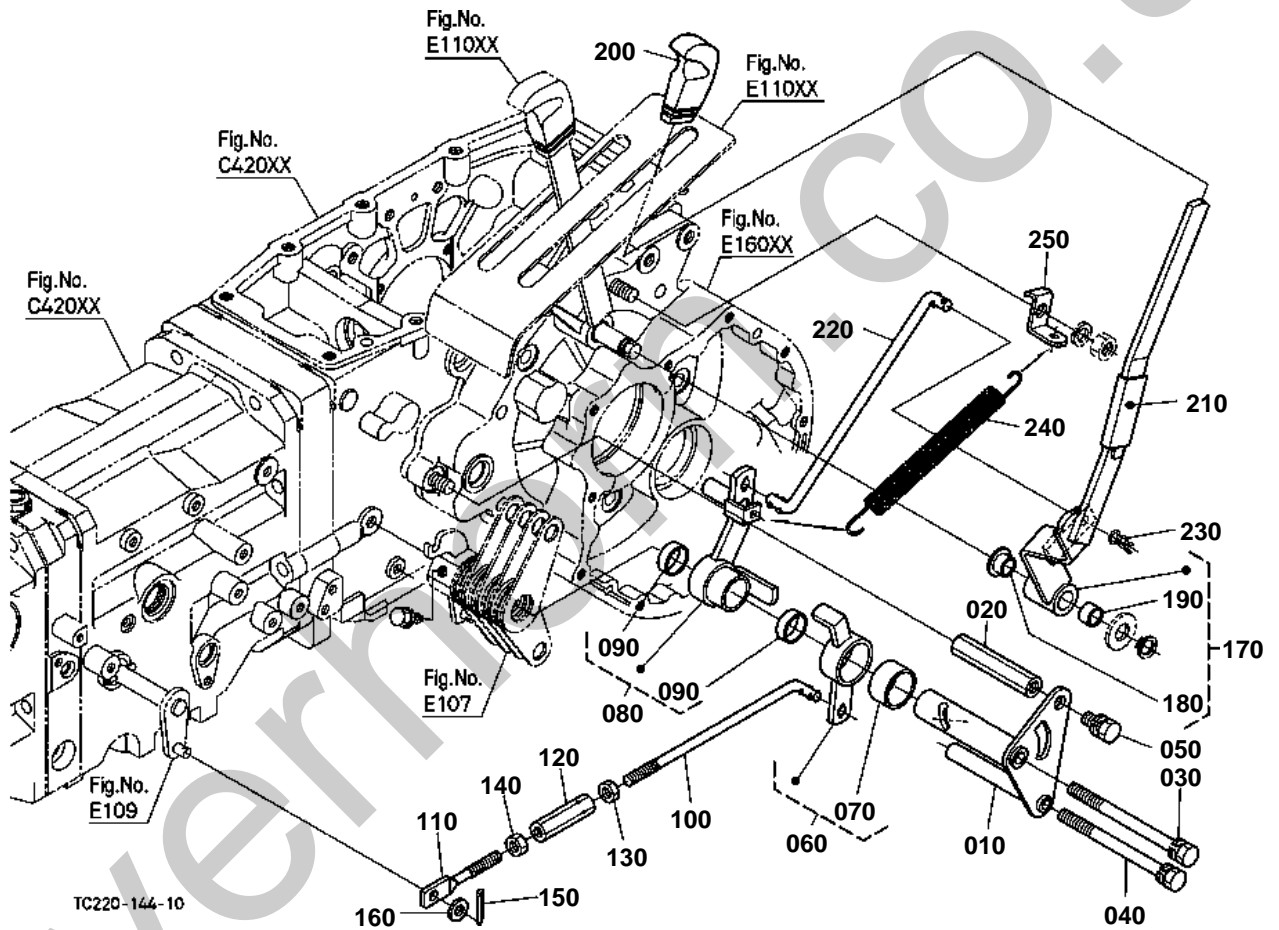



# CRUISE CONTROL LEVER [HST TYPE]

↔ Interchangeable; ≠ not interchangeable; ← new for old; → old for new

REF.No	Part No.	Description	Q'ty	S.No.	I/C	REMARKS	Weight (kgf)	Weight (lb)
010	TC220-55270	HOLDER	1				0	0
020	TC220-55320	BOSS CRUISE CONTROL	1				0	0
030	T1170-27380	BOLT REAR AXLE	1				0.12	0.264
040	TD060-55720	BOLT	1				0.085	0.187
050	01133-51220	BOLT	1				0.04	0.088
060	TC220-55950	ASSY LEVER CONTROL	1				0	0
070	08511-03520	BUSH	1				0.034	0.0748
080	TC220-55910	ASSY LEVER SPEED SET	1				0.39	0.858
090	08511-02510	BUSH	2				0.012	0.0264
100	TC220-55300	ROD	1				0	0
110	T1150-24380	ROD SHIFT	1				0.041	0.0902
120	37410-42180	TURNBUCKLE	1				0.05	0.11
130	32350-28990	NUT	1				0.009	0.0198
140	02118-50100	NUT	1				0.005	0.011
150	05511-50318	PIN SPLIT	1				0.001	0.0022
160	04013-60100	WASHER PLAIN	1				0.003	0.0066
170	TC220-55920	ASSY LEVER CRUISE	1				0	0
180	T1060-24570	BUSH	1				0.005	0.011
190	T1060-24460	BUSH	1				0.005	0.011
200	TD060-24490	GRIP LEVER	1				0.045	0.099
210	6A100-18560	CUSHION	1				0.005	0.011
220	TC220-55850	ROD SPEED SET	1				0	0
230	05515-61000	PIN SNAP	1				0.002	0.0044
240	TD060-55260	SPRING CRUISE	1				0.038	0.0836
250	TC220-55770	HOLDER SPRING	1				0	0

CRUISE CONTROL CABLE [HST TYPE]

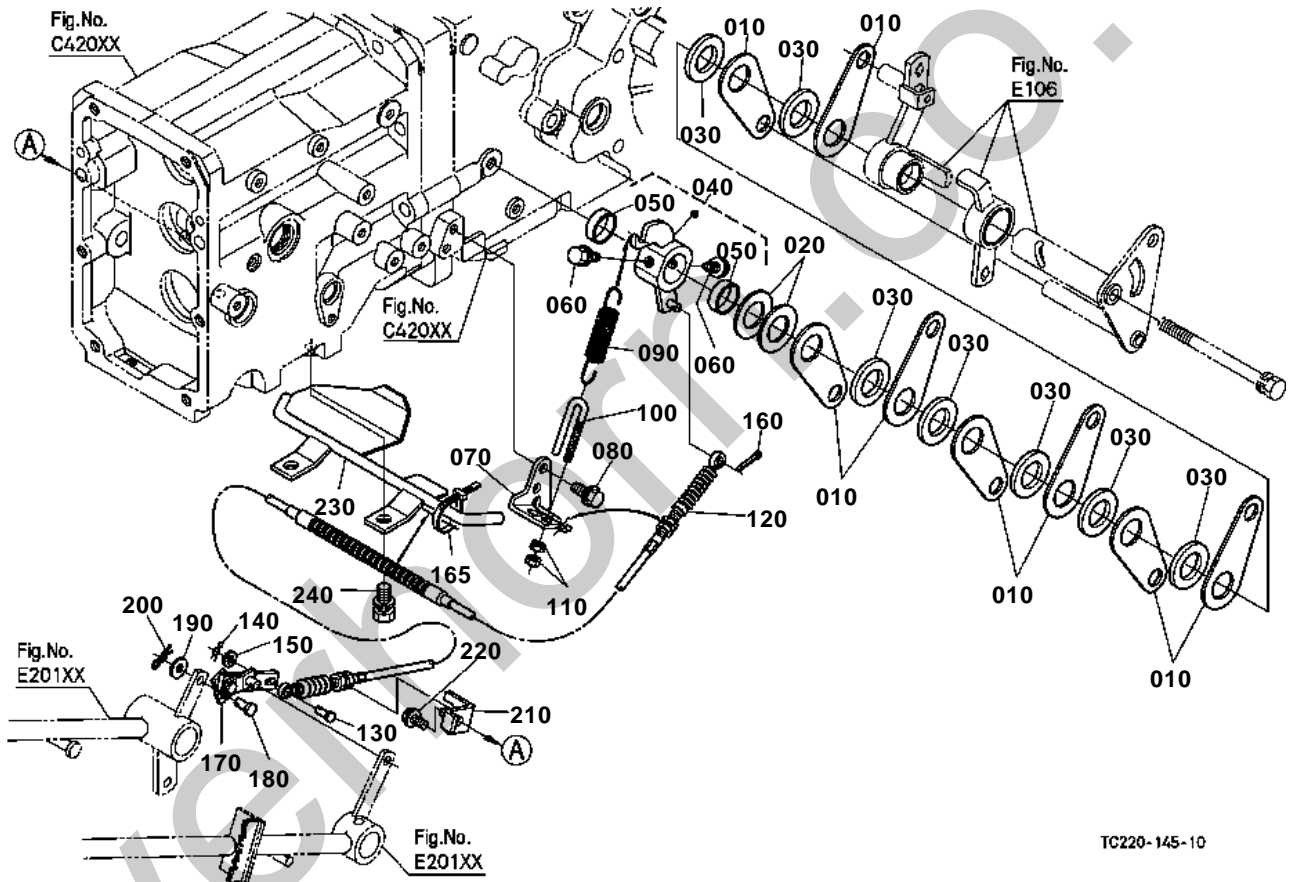



# CRUISE CONTROL CABLE [HST TYPE]

↔ Interchangeable; ≠ not interchangeable; ← new for old; → old for new

REF.No	Part No.	Description	Q'ty	S.No.	I/C	REMARKS	Weight (kgf)	Weight (lb)
010	TD060-55800	PLATE FRICTION	8				0.025	0.055
020	TD060-55810	SHIM	4			0.4mm	0.05	0.11
030	TD060-55840	DISK FRICTION	7				0.007	0.0154
040	TC220-55960	ASSY LEVER CRUISE	1				0	0
050	08511-02510	BUSH	2				0.012	0.0264
060	37500-42250	BOLT	2				0.012	0.0264
070	TC220-55180	BRACKET SPEED SET	1				0	0
080	01754-50816	BOLT FLANGE	2				0.011	0.0242
090	TC220-55820	SPRING SPEED SET	1				0	0
100	TD060-55790	ROD ADJUSTING	1				0.025	0.055
110	02056-50060	NUT	2				0.002	0.0044
120	TC220-55700	CABLE CRUISE	1				0	0
130	05122-50616	PIN JOINT	1				0.004	0.0088
140	05525-60600	PIN SNAP	1				0.001	0.0022
150	04012-50060	WASHER PLAIN	1				0.001	0.0022
160	05511-51612	PIN SPLIT	1				0.001	0.0022
165	53581-64150	BAND CORD	1				0.002	0.0044
170	TC220-57322	COMP.LINK	1				0	0
180	05122-50814	PIN JOINT	1				0.005	0.011
190	04013-60080	WASHER PLAIN	1				0.002	0.0044
200	05525-50800	PIN SNAP	1				0.001	0.0022
210	TC220-55712	BRACKET CABLE	1				0	0
220	01754-50816	BOLT FLANGE	1				0.011	0.0242
230	TC220-55722	GUIDE CRUISE WIRE	1				0	0
240	01133-51225	BOLT	2				0.035	0.077

NEUTRAL HOLDER ARM [HST TYPE]

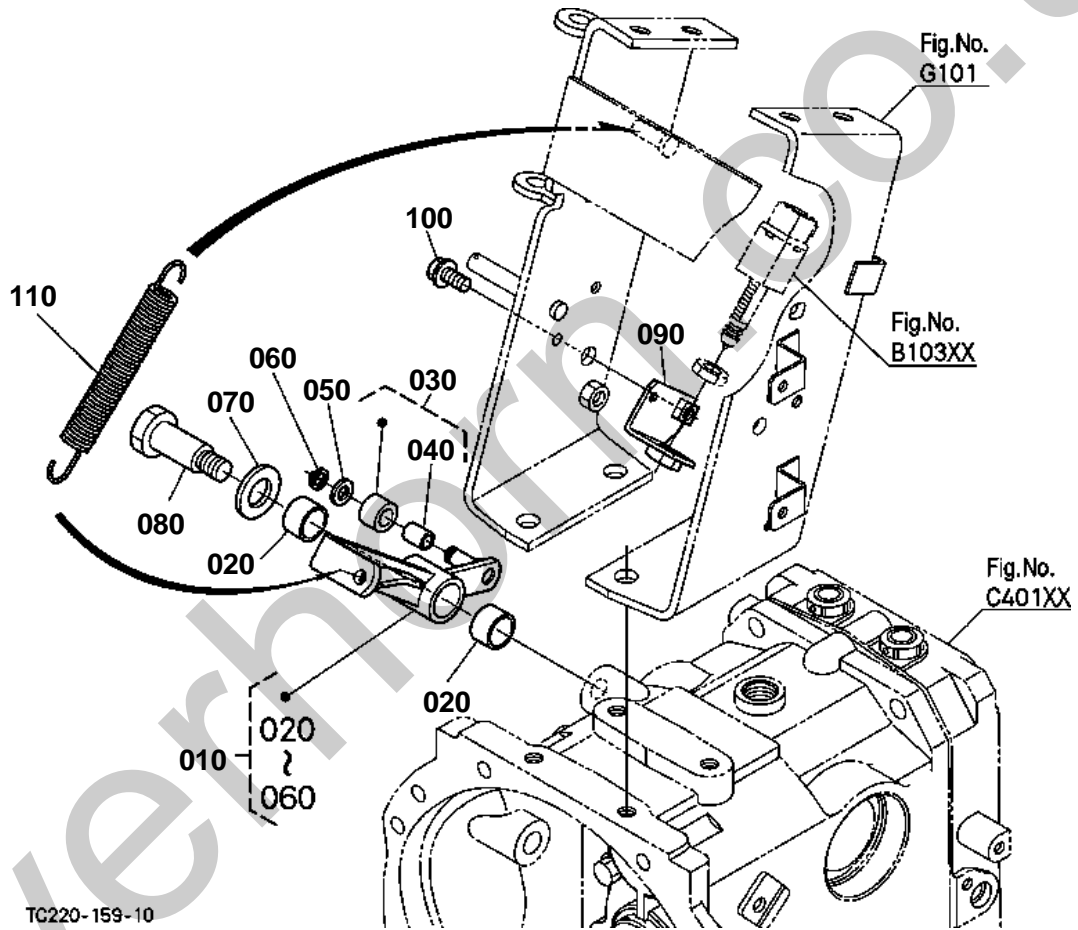

TC220-159-10



# NEUTRAL HOLDER ARM [HST TYPE]

↔ Interchangeable; ≠ not interchangeable; ← new for old; → old for new

REF.No	Part No.	Description	Q'ty	S.No.	I/C	REMARKS	Weight (kgf)	Weight (lb)
010	TC220-55653	ASSY ARM NEUT.HOLDER	1				0	0
020	08511-02015	BUSH	2				0.011	0.0242
030	TC220-55220	ASSY CAM	1				0.024	0.0528
040	08511-01015	BUSH	1				0.003	0.0066
050	04011-50100	WASHER PLAIN	1				0.002	0.0044
060	04612-00100	CIR CLIP EXTERNAL	1				0.001	0.0022
070	04011-50200	WASHER PLAIN	1				0.015	0.033
080	TC220-55202	BOLT NEUTRAL	1				0	0
090	TC220-55570	HOLDER NEUTRAL SWIT.	1				0	0
100	01754-50816	BOLT FLANGE	1				0.011	0.0242
110	TC220-55592	SPRING NEUTRAL	1				0	0



SPEED CONTROL PEDAL [HST TYPE]

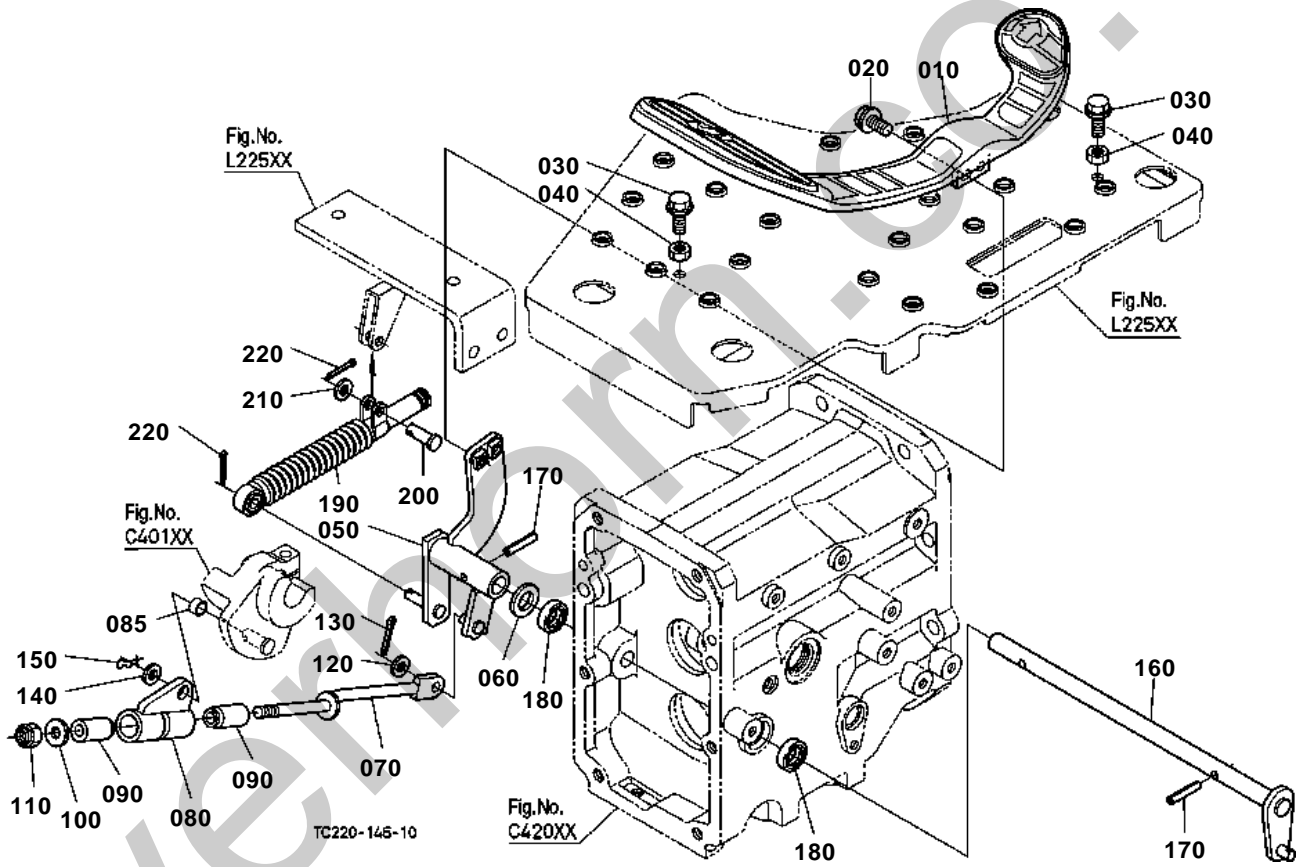



## SPEED CONTROL PEDAL [HST TYPE]

↔ Interchangeable; ≠ not interchangeable; ← new for old; → old for new

REF.No	Part No.	Description	Q'ty	S.No.	I/C	REMARKS	Weight (kgf)	Weight (lb)
010	TD060-55543	PEDAL HST CONTROL	1				0.33	0.726
020	01754-50820	BOLT FLANGE	2				0.015	0.033
030	01754-50825	BOLT FLANGE	2				0.01	0.022
040	02112-50080	NUT	2				0.003	0.0066
050	TC220-55522	LEVER HST PEDAL	1				0.56	1.232
060	04011-60160	WASHER PLAIN	1				0.01	0.022
070	TC220-55543	ROD HST PEDAL	1				0	0
080	TC220-55553	HOLDER CUSHION	1				0	0
085	08511-01010	BUSH	1				0.003	0.0066
090	TC220-55582	CUSHION PEDAL	2				0.01	0.022
100	04013-60100	WASHER PLAIN	1				0.003	0.0066
110	02574-50100	NUT LOCK	1				0.007	0.0154
120	04013-60100	WASHER PLAIN	1				0.003	0.0066
130	05511-50318	PIN SPLIT	1				0.001	0.0022
140	04011-50100	WASHER PLAIN	1				0.002	0.0044
150	52300-34130	PIN SNAP	1				0.004	0.0088
160	TC220-55533	SHAFT HST PEDAL	1				0.6	1.32
170	05411-00635	PIN SPRING	2				0.005	0.011
180	09500-16267	SEAL OIL	2				0.005	0.011
190	32721-43350	DAMPER HST	1				0.26	0.572
200	05122-50828	PIN JOINT	1				0.012	0.0264
210	04012-50080	WASHER PLAIN	1				0.001	0.0022
220	05511-50215	PIN SPLIT	2				0.001	0.0022

RANGE GEAR SHIFT LEVER [EXCEPT HST TYPE]

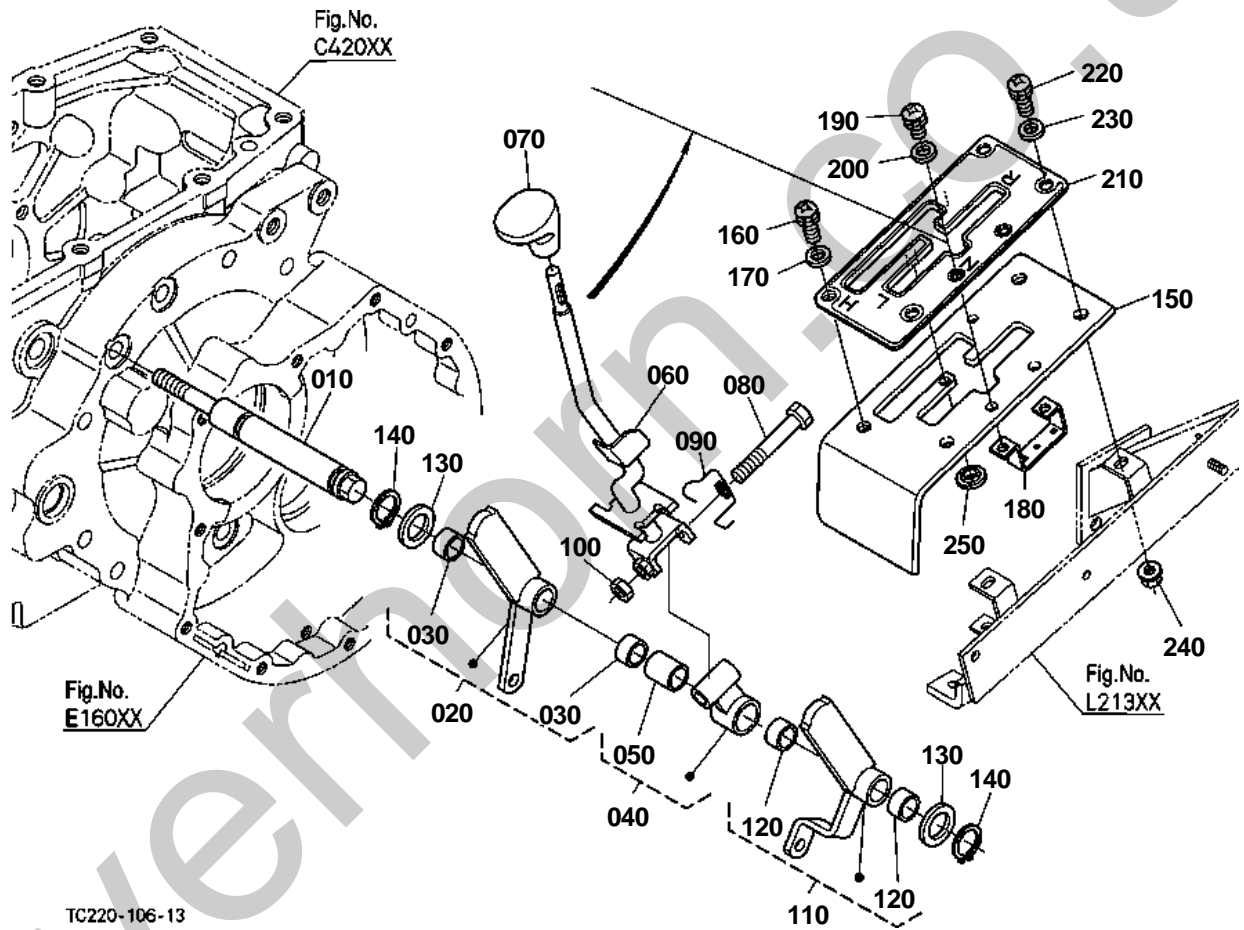

## OLD PARTS

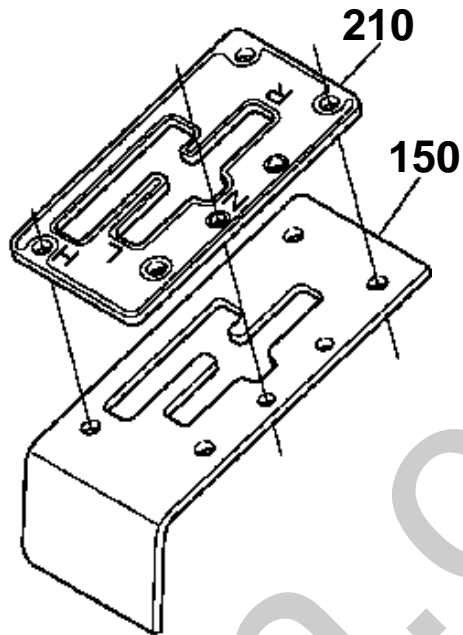

Silverhorn.CO.UK

TC227-802-10

**RANGE GEAR SHIFT LEVER [EXCEPT HST TYPE]**

↔ Interchangeable; ≠ not interchangeable; ← new for old; → old for new

REF.No	Part No.	Description	Q'ty	S.No.	I/C	REMARKS	Weight (kgf)	Weight (lb)
010	TC220-24480	BOLT	1				0.29	0.638
020	TC220-24710	ASSY ARM SHIFT	1				0.41	0.902
030	T1060-24460	BUSH	2				0.005	0.011
040	TA240-54752	ASSY HOLDER RANGE	1				0.15	0.33
050	08511-01825	BUSH	1				0.01	0.022
060	TC220-24470	LEVER RANGE SHIFT	1				0.7	1.54
070	PK401-73270	GRIP MAIN SP-CHANGE	1				0.075	0.165
080	TA240-54660	BOLT	1				0.045	0.099
090	TC050-24780	SPRING	1	<=57744			0.015	0.033
090	TC050-24782	SPRING	1	>=57745	↔		0.015	0.033
100	02156-50080	NUT	1				0.004	0.0088
110	TC220-24730	ASSY ARM SHIFT	1				0.41	0.902
120	T1060-24460	BUSH	2				0.005	0.011
130	04011-50180	WASHER PLAIN	2				0.012	0.0264
140	04612-00180	CIR CLIP EXTERNAL	2				0.001	0.0022
150	TC050-47200	GUIDE SHIFT	1	<=55198			0.93	2.046
150	TC050-47202	GUIDE SHIFT	1	>=55199	↔		0.93	2.046
160	03004-60825	SCREW WITH WASHER	2				0.14	0.308
170	04013-60080	WASHER PLAIN	2				0.002	0.0044
180	TC220-43980	STAY SWITCH	1				0.04	0.088
190	03004-60620	SCREW WITH WASHER	2				0.005	0.011
200	04013-60060	WASHER PLAIN	2				0.001	0.0022
210	TC050-47152	GUIDE RANGE SHIFT	1	<=55198			0.067	0.1474
210	TC050-47153	GUIDE RANGE SHIFT	1	>=55199	↔		0.067	0.1474
220	03004-60825	SCREW WITH WASHER	2				0.14	0.308
230	04013-60080	WASHER PLAIN	2				0.002	0.0044
240	02751-50080	NUT FLANGE	2				0.006	0.0132
250	RA111-43690	NUT	2	>=55199			0.001	0.0022

RANGE GEAR SHIFT LEVER [HST TYPE]

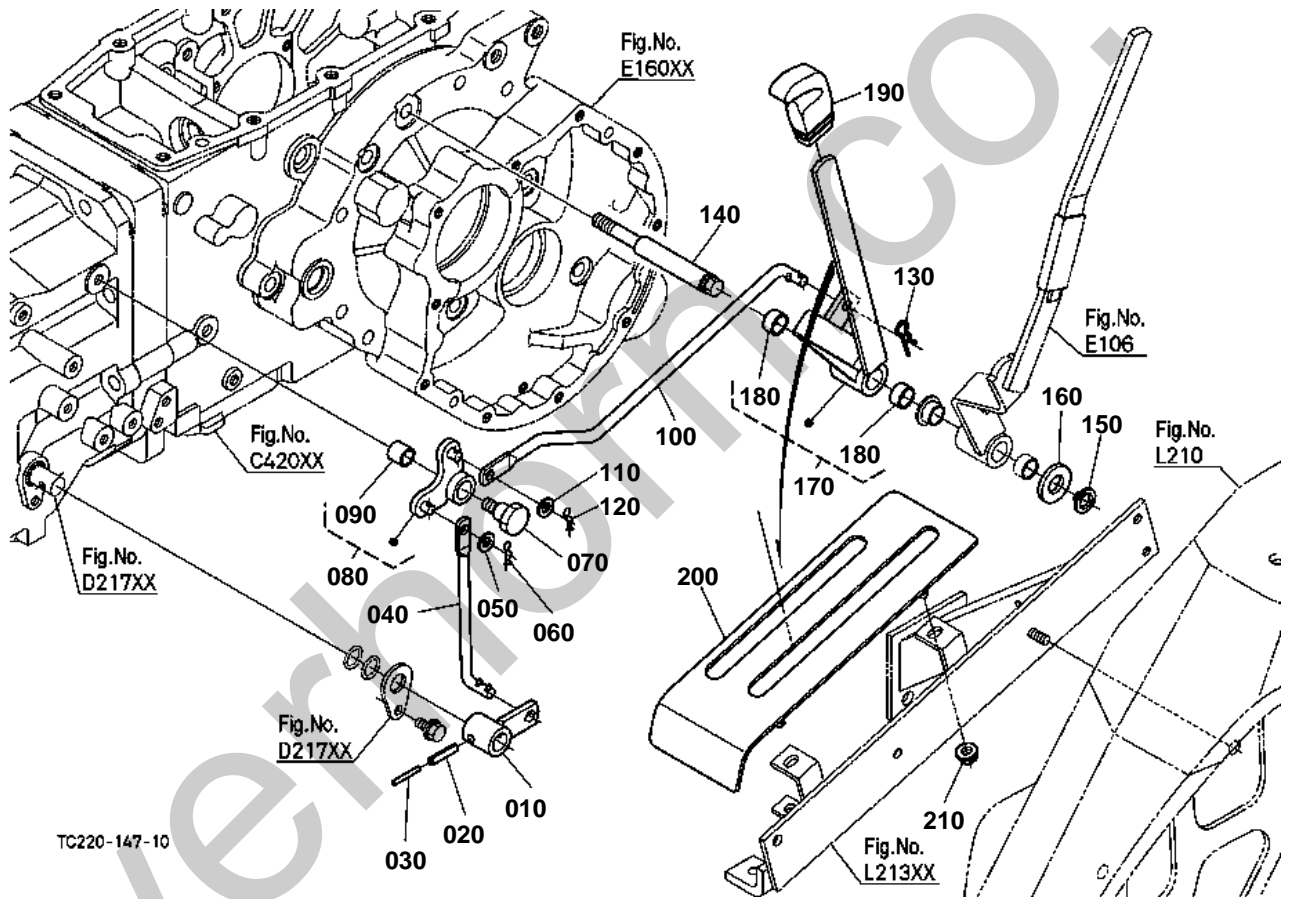

TC220-147-10



## RANGE GEAR SHIFT LEVER [HST TYPE]

↔ Interchangeable; ≠ not interchangeable; ← new for old; → old for new

REF.No	Part No.	Description	Q'ty	S.No.	I/C	REMARKS	Weight (kgf)	Weight (lb)
010	TC220-54560	LEVER RANGE SHIFT	1				0	0
020	05411-00630	PIN SPRING	1				0.004	0.0088
030	T0270-15310	PIN SPRING	1				0.002	0.0044
040	TC220-54570	ROD RANGE SHIFT	1				0	0
050	04012-50080	WASHER PLAIN	1				0.001	0.0022
060	52300-34120	PIN SNAP	1				0.001	0.0022
070	TC220-54550	BOLT RANGE SHIFT	1				0	0
080	TC220-54600	ASSY LEVER R/SHIFT	1				0	0
090	08511-01515	BUSH	1				0.002	0.0044
100	TC220-54590	ROD RANGE SHIFT	1				0	0
110	04012-50080	WASHER PLAIN	1				0.001	0.0022
120	52300-34120	PIN SNAP	1				0.001	0.0022
130	05515-61000	PIN SNAP	1				0.002	0.0044
140	TC220-55340	BOLT	1				0	0
150	04612-00180	CIR CLIP EXTERNAL	1				0.001	0.0022
160	04011-50180	WASHER PLAIN	1				0.012	0.0264
170	TC220-54680	ASSY LEVER R/SHIFT	1				0	0
180	T1060-24460	BUSH	2				0.005	0.011
190	TD060-24490	GRIP LEVER	1				0.045	0.099
200	TC220-57562	GUIDE HST CAHNGE	1				0	0
210	02751-50080	NUT FLANGE	2				0.006	0.0132

RANGE GEAR SHIFT ROD [EXCEPT HST TYPE]

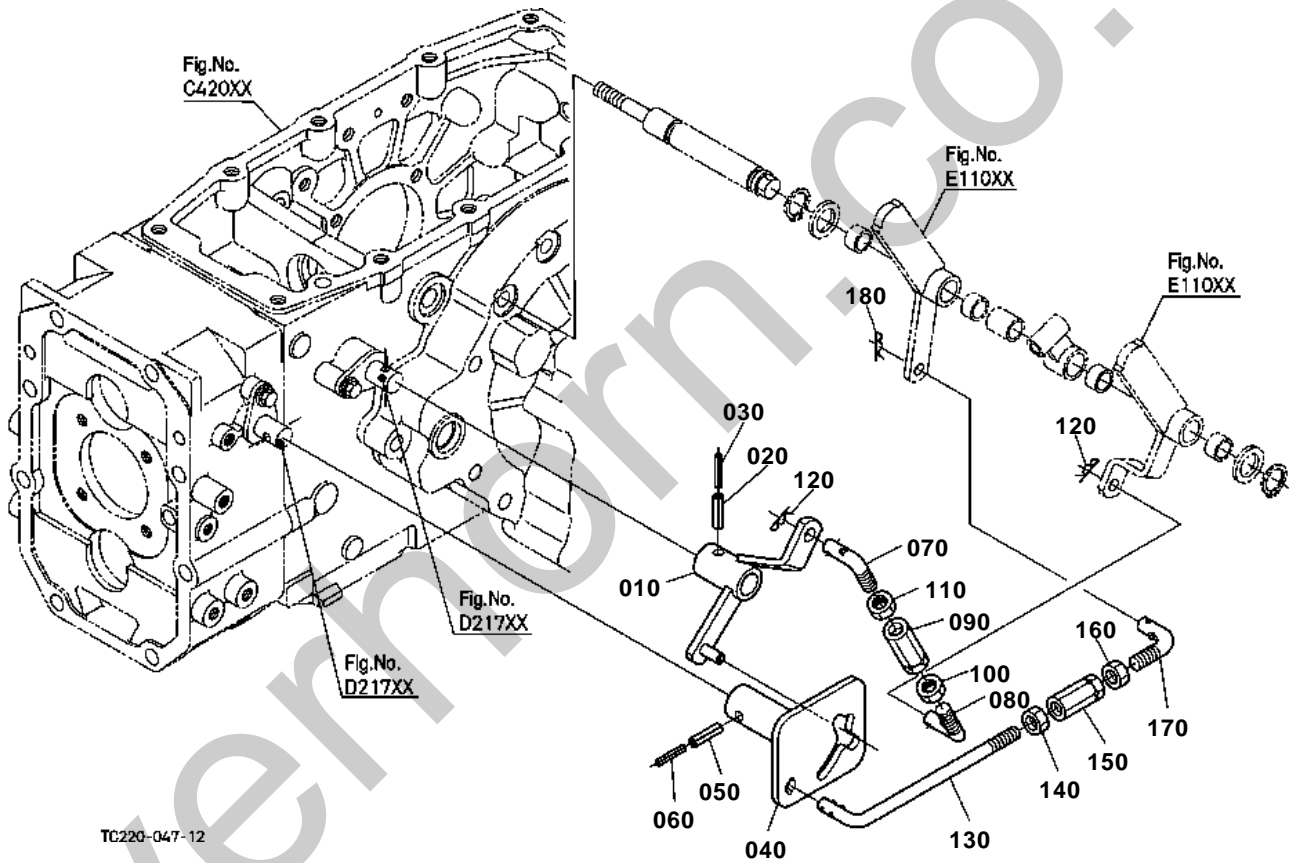

TC220-047-12





# RANGE GEAR SHIFT ROD [EXCEPT HST TYPE]

↔ Interchangeable; ≠ not interchangeable; ← new for old; → old for new

REF.No	Part No.	Description	Q'ty	S.No.	I/C	REMARKS	Weight (kgf)	Weight (lb)
010	TC220-24460	LEVER SHIFT	1				0.26	0.572
020	05411-00635	PIN SPRING	1				0.005	0.011
030	70451-57350	PIN SPRING	1				0.005	0.011
040	TC220-24700	LEVER SHIFT	1				0.41	0.902
050	05411-00635	PIN SPRING	1				0.005	0.011
060	70451-57350	PIN SPRING	1				0.005	0.011
070	TA240-54582	ROD RANGE R	1				0.03	0.066
080	TA240-54592	ROD RANGE L	1				0.03	0.066
090	TA240-54480	TURNBUCKLE	1				0.031	0.0682
100	32350-28990	NUT	1				0.009	0.0198
110	02116-50100	NUT	1				0.004	0.0088
120	05515-61000	PIN SNAP	2				0.002	0.0044
130	TC050-24762	ROD RANGE SHIFT	1				0.11	0.242
140	02116-50100	NUT	1				0.004	0.0088
150	TA240-54480	TURNBUCKLE	1				0.031	0.0682
160	32350-28990	NUT	1				0.009	0.0198
170	TA240-54592	ROD RANGE L	1				0.03	0.066
180	05515-61000	PIN SNAP	1				0.002	0.0044

PTO GEAR SHIFT LEVER [EXCEPT HST TYPE]

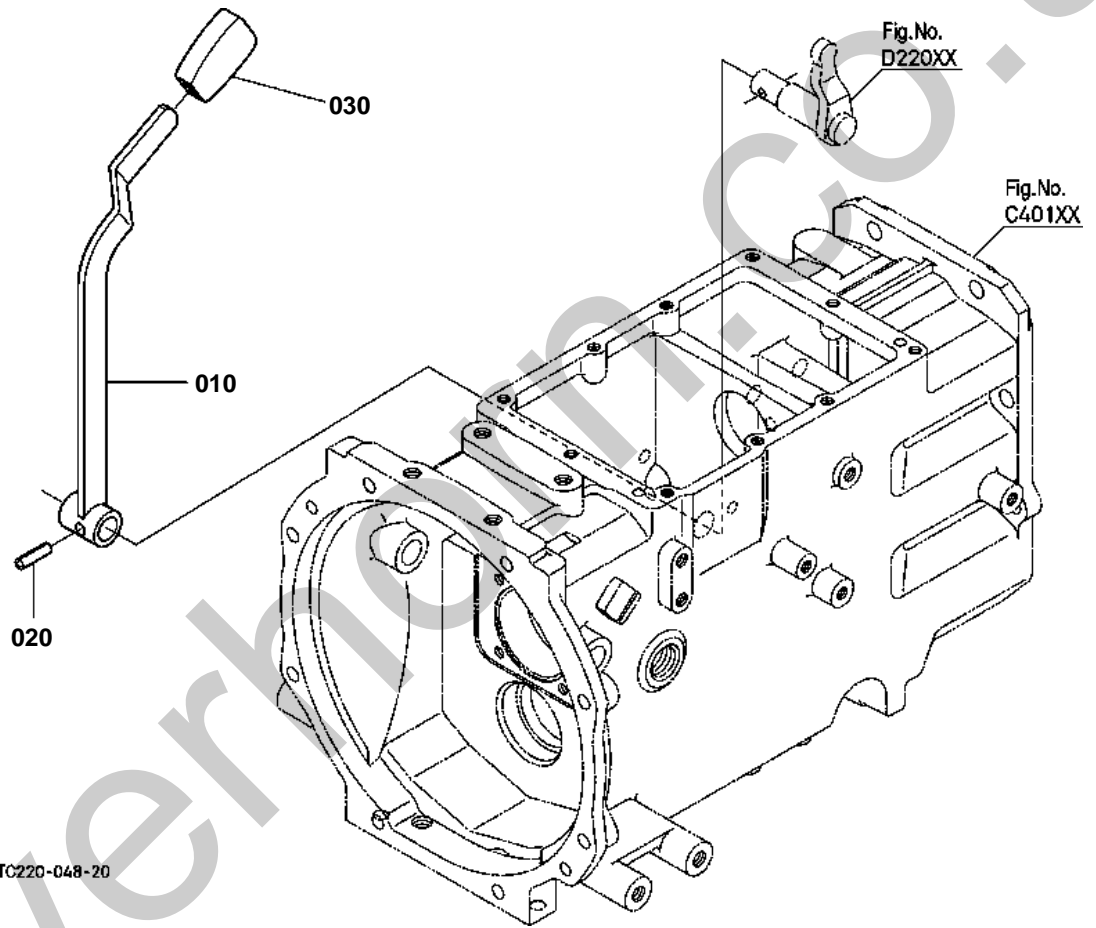

TC220-048-20



## PTO GEAR SHIFT LEVER [EXCEPT HST TYPE]

↔ Interchangeable; ≠ not interchangeable; ← new for old; → old for new

REF.No	Part No.	Description	Q'ty	S.No.	I/C	REMARKS	Weight (kgf)	Weight (lb)
010	TC220-24640	LEVER PTO SHIFT	1				0.41	0.902
020	05411-00628	PIN SPRING	1				0.004	0.0088
030	6A320-42780	GRIP LEVER	1				0.034	0.0748

PTO CLUTCH CONTROL LEVER [HST TYPE]

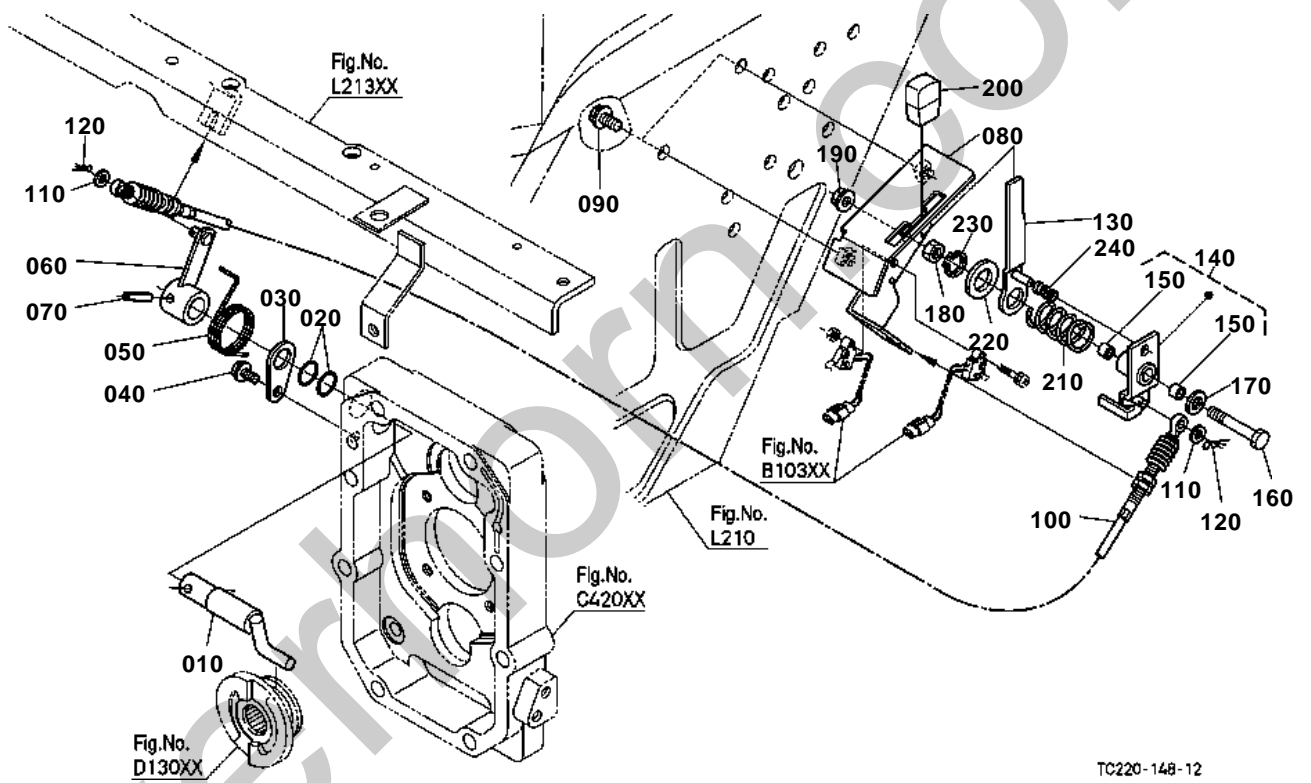

TC220-148-12

## OLD PARTS

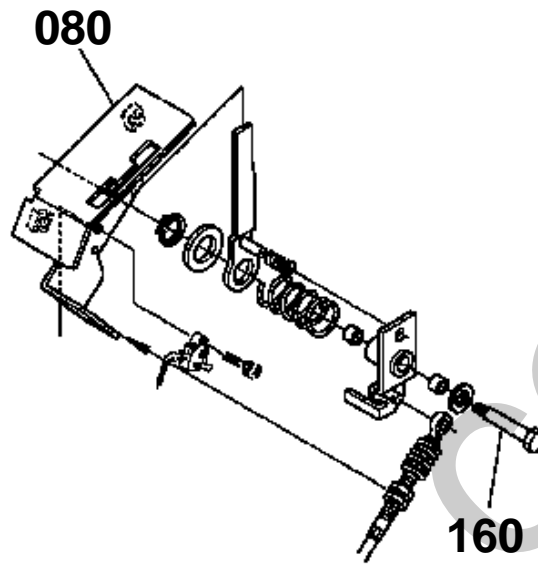

TC220-848-10



PTO CLUTCH CONTROL LEVER [HST TYPE]

↔ Interchangeable; ≠ not interchangeable; ← new for old; → old for new

REF.No	Part No.	Description	Q'ty	S.No.	I/C	REMARKS	Weight (kgf)	Weight (lb)
010	TC220-54610	ARM PTO SHIFT	1				0.185	0.407
020	04816-00200	O RING	2				0.003	0.0066
030	34070-24350	STOPPER	1				0.02	0.044
040	01754-50812	BOLT FLANGE	1				0.01	0.022
050	TA040-24610	SPRING	1				0.029	0.0638
060	TA040-24620	LEVER PTO	1				0.08	0.176
070	05411-00628	PIN SPRING	1				0.004	0.0088
080	TC050-47610	GUIDE PTO LEVER	1	<=56786			0.3	0.66
080	TC050-47612	GUIDE PTO LEVER	1	>=56787	1		0.3	0.66
090	01754-50816	BOLT FLANGE	2				0.011	0.0242
100	TC220-57650	WIRE PTO	1				0.11	0.242
110	04012-50060	WASHER PLAIN	2				0.001	0.0022
120	05525-60600	PIN SNAP	2				0.001	0.0022
130	3A012-27810	LEVER PTO CLUTCH	1				0.049	0.1078
140	TD060-69722	ASSY CAM PTO LEVER	1				0.095	0.209
150	08511-00810	BUSH	2				0.003	0.0066
160	TD060-69740	PIN PTO LEVER	1	<=56786			0.02	0.044
160	TC220-59740	PIN PTO LEVER	1	>=45787	1		0	0
170	04013-60080	WASHER PLAIN	1				0.002	0.0044
180	02112-50080	NUT	1	>=56787			0.003	0.0066
190	02761-50060	NUT FLANGE	1	<=56786			0.003	0.0066
190	02761-50080	NUT FLANGE	1	>=56787	1		0.008	0.0176
190	02763-50080	NUT FLANGE	1	>=57223	1		0.006	0.0132
200	36919-27820	GRIP PTO LEVER	1				0.015	0.033
210	3A012-27850	SPRING	1				0.005	0.011
220	04011-50180	WASHER PLAIN	1				0.012	0.0264
230	04612-00180	CIR CLIP EXTERNAL	1				0.001	0.0022
240	3A111-27830	SPRING PTO LEVER	1				0.001	0.0022

FRONT WHEEL DRIVE LEVER [EXCEPT HST TYPE]

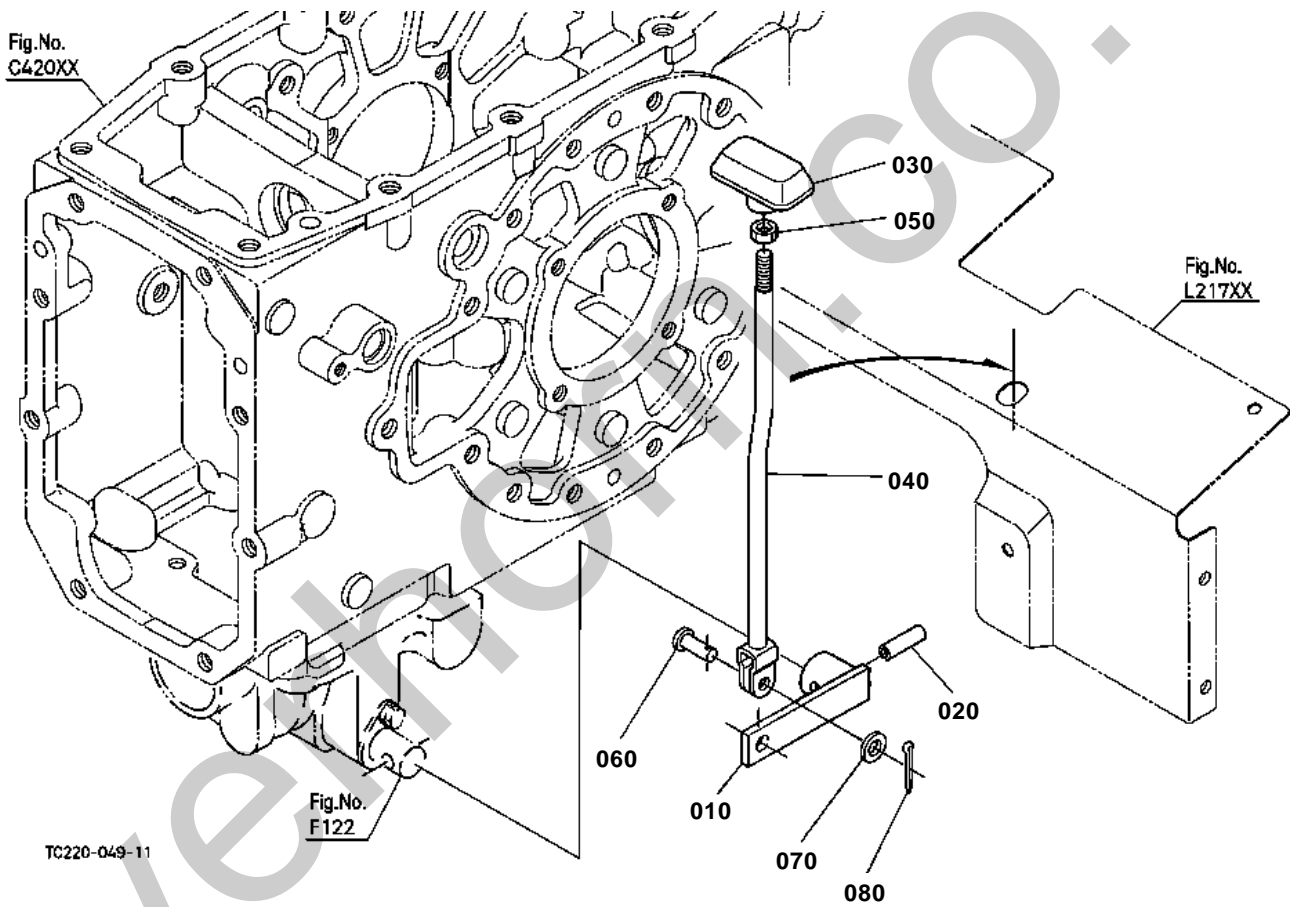



# FRONT WHEEL DRIVE LEVER [EXCEPT HST TYPE]

↔ Interchangeable; ≠ not interchangeable; ← new for old; → old for new

REF.No	Part No.	Description	Q'ty	S.No.	I/C	REMARKS	Weight (kgf)	Weight (lb)
010	35010-44360	LEVER CHANGE	1				0.2	0.44
020	05411-00625	PIN SPRING	1				0.004	0.0088
030	3A121-41450	GRIP LEVER	1				0.035	0.077
040	TC220-44400	LEVER FRONT DRIVE	1				0.44	0.968
050	02116-50100	NUT	1				0.004	0.0088
060	05122-51022	PIN JOINT	1				0.014	0.0308
070	04013-60100	WASHER PLAIN	1				0.003	0.0066
080	05511-50318	PIN SPLIT	1				0.001	0.0022



FRONT WHEEL DRIVE LEVER [HST TYPE]

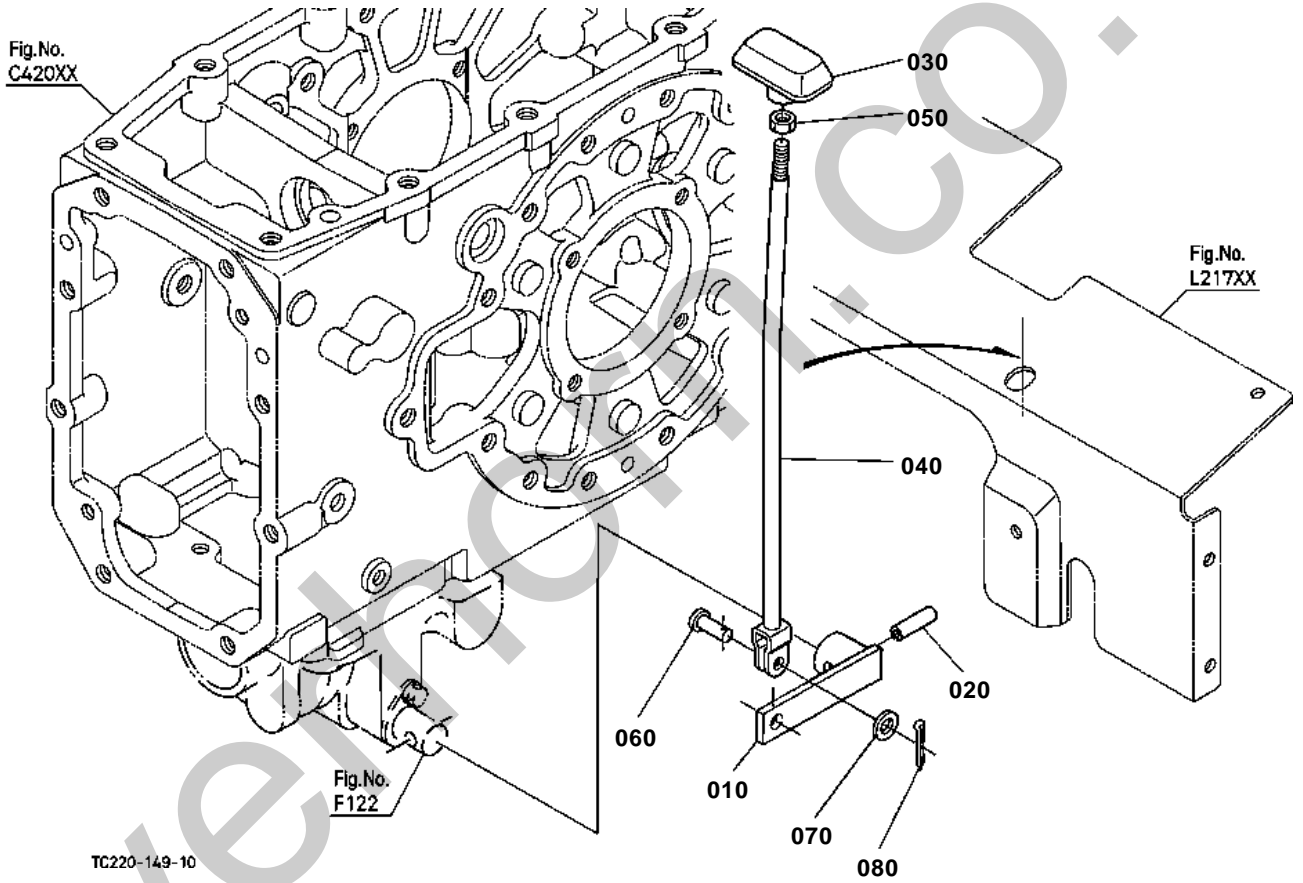



# FRONT WHEEL DRIVE LEVER [HST TYPE]

↔ Interchangeable; ≠ not interchangeable; ← new for old; → old for new

REF.No	Part No.	Description	Q'ty	S.No.	I/C	REMARKS	Weight (kgf)	Weight (lb)
010	35010-44360	LEVER CHANGE	1				0.2	0.44
020	05411-00625	PIN SPRING	1				0.004	0.0088
030	3A121-41450	GRIP LEVER	1				0.035	0.077
040	TC220-57730	LEVER FRONT DRIVE	1				0	0
050	02116-50100	NUT	1				0.004	0.0088
060	05122-51022	PIN JOINT	1				0.014	0.0308
070	04013-60100	WASHER PLAIN	1				0.003	0.0066
080	05511-50318	PIN SPLIT	1				0.001	0.0022

REAR AXLE

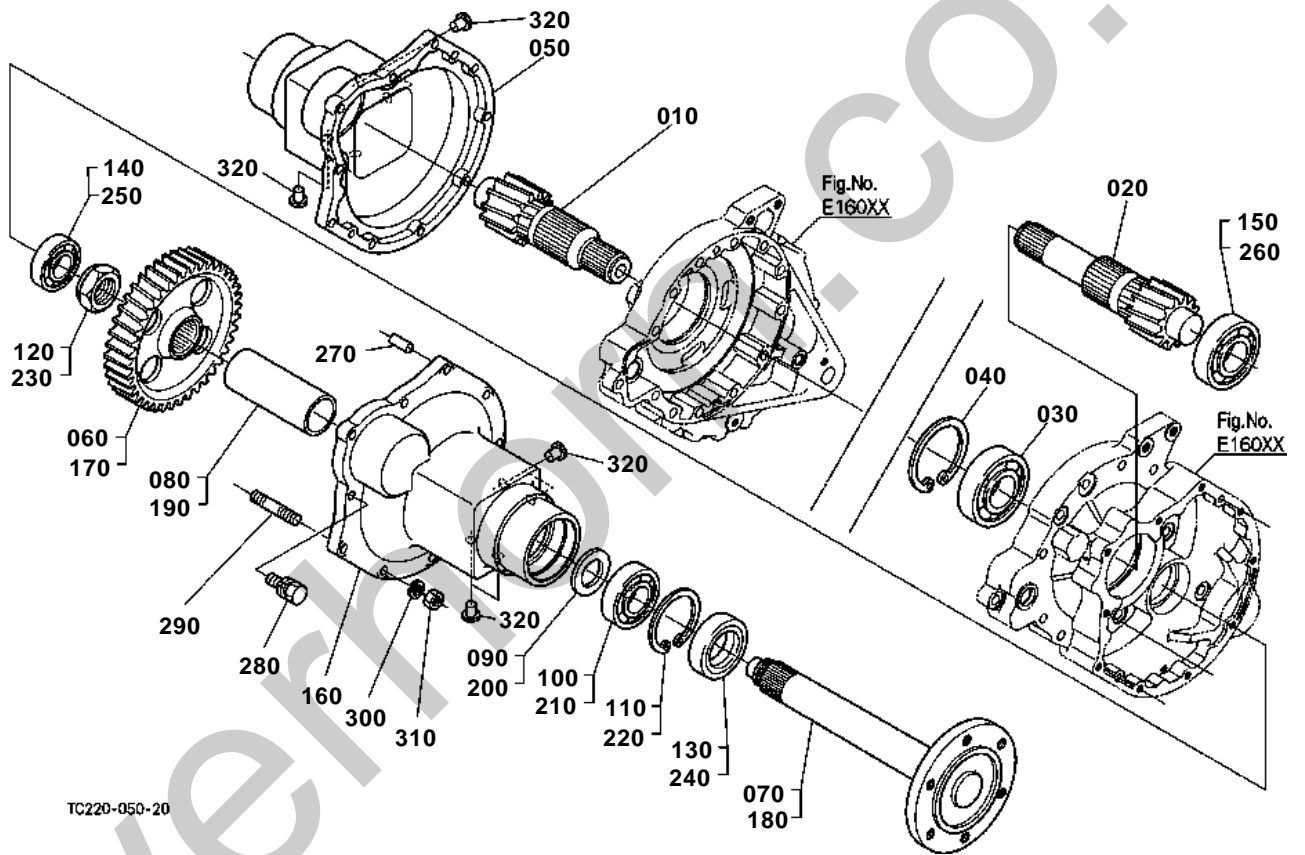



REAR AXLE

↔ Interchangeable; ≠ not interchangeable; ← new for old; → old for new

REF.No	Part No.	Description	Q'ty	S.No.	I/C	REMARKS	Weight (kgf)	Weight (lb)
010	32410-26710	SHAFT DIFF.GEAR RH	1	≤53276		11T	0	0
010	32410-26712	SHAFT DIFF.GEAR RH	1	≥53277	-	11T	1.86	4.092
020	32410-26720	SHAFT DIFF.GEAR LH	1	≤53276		11T	2.06	4.532
020	32410-26722	SHAFT DIFF.GEAR LH	1	≥53277	-	11T	2.06	4.532
030	TD060-26730	BEARING BALL	2				0.81	1.782
040	04611-01000	CIR CLIP INTERNAL	2				0.042	0.0924
050	TC220-27310	CASE AXLE RH	1				11	24.2
060	31331-26832	GEAR	1			53T	4.85	10.67
070	32400-27110	AXLE REAR	1				9.15	20.13
080	32400-27140	SPACER	1				0.93	2.046
090	T0030-27160	WASHER	1				0.008	0.0176
100	TC220-27420	BEARING BALL	1				0.4	0.88
110	04611-00850	CIR CLIP INTERNAL	1				0.029	0.0638
120	70650-11380	NUT	1				0.11	0.242
130	37150-27560	SEAL OIL	1				0.14	0.308
140	TC220-27410	BEARING BALL	1	≤52320			0.34	0.748
140	08101-06306	BEARING BALL	1	≥52321	-		0.335	0.737
150	TD030-12540	BEARING BALL	1				0.45	0.99
160	TC220-27330	CASE REAR AXLE LH	1				11	24.2
170	31331-26832	GEAR	1			53T	4.85	10.67
180	32400-27110	AXLE REAR	1				9.15	20.13
190	32400-27140	SPACER	1				0.93	2.046
200	T0030-27160	WASHER	1				0.008	0.0176
210	TC220-27420	BEARING BALL	1				0.4	0.88
220	04611-00850	CIR CLIP INTERNAL	1				0.029	0.0638
230	70650-11380	NUT	1				0.11	0.242
240	37150-27560	SEAL OIL	1				0.14	0.308
250	TC220-27410	BEARING BALL	1	≤52320			0.34	0.748
250	08101-06306	BEARING BALL	1	≥52321	-		0.335	0.737
260	TD030-12540	BEARING BALL	1				0.45	0.99
270	05012-01018	PIN STRAIGHT	4				0.012	0.0264
280	01133-51035	BOLT	16				0.03	0.066
290	01517-51035	STUD	4				0.028	0.0616
300	04512-60100	WASHER SPRING	4				0.002	0.0044
310	02176-50100	NUT	4				0.005	0.011
320	31220-14290	PLUG	12	≥53882			0.002	0.0044

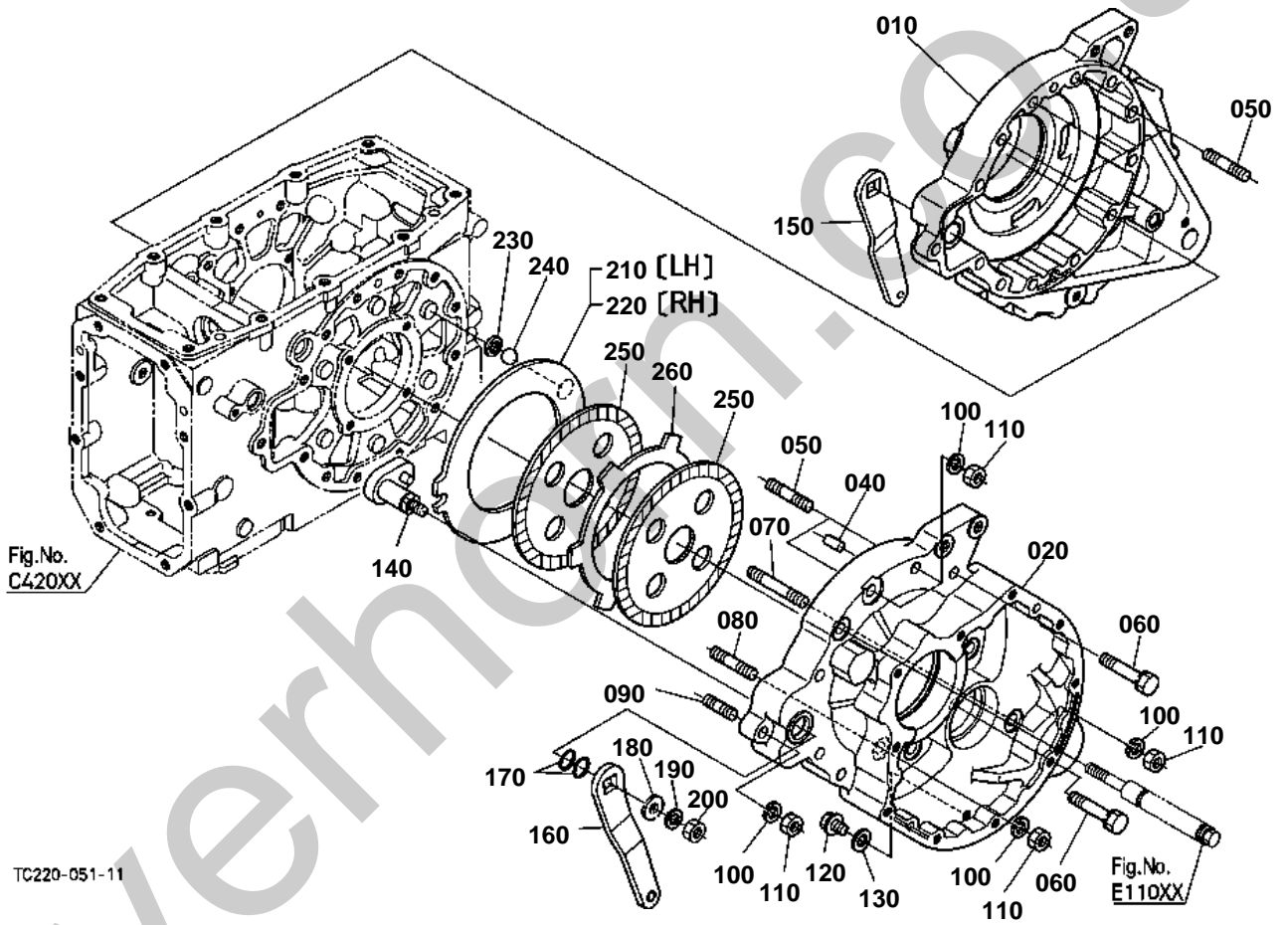
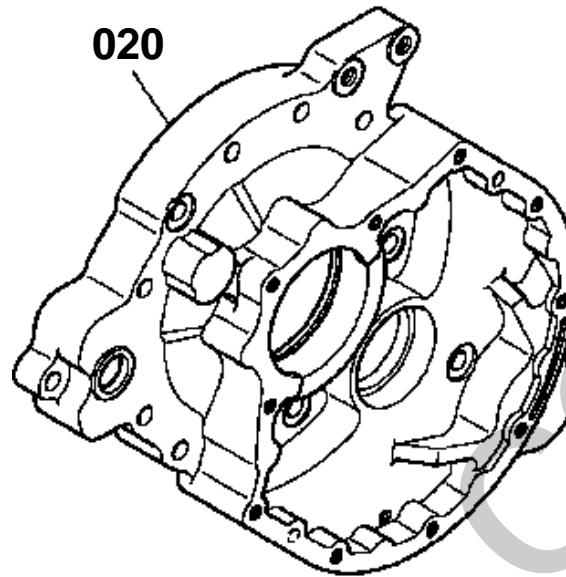

Fig.No. C420XX

Fig.No. E110XX

TC220-051-11

## OLD PARTS



TC220-833-10



## BRAKE [EXCEPT HST TYPE]

↔ Interchangeable; ≠ not interchangeable; ← new for old; → old for new

REF.No	Part No.	Description	Q'ty	S.No.	I/C	REMARKS	Weight (kgf)	Weight (lb)
010	TC220-28130	CASE BRAKE RH	1	<=51027			0	0
010	TC220-28134	CASE BRAKE RH	1	>=51028	-		17.8	39.16
020	TC220-28150	CASE BRAKE LH	1	<=51027			0	0
020	TC220-28154	CASE BRAKE LH	1	>=51028	-		17.8	39.16
030	99999-99999	BLANK	0				0	0
040	05012-01018	PIN STRAIGHT	4				0.012	0.0264
050	37150-27350	STUD	5				0.06	0.132
060	01133-51260	BOLT	10				0.06	0.132
070	01574-51280	STUD	2				0.08	0.176
080	01574-61260	STUD	8				0.05	0.11
090	01574-61235	STUD	2				0.04	0.088
100	04512-60120	WASHER SPRING	17				0.005	0.011
110	02176-50120	NUT	17				0.01	0.022
120	06331-45010	PLUG	2				0.02	0.044
130	04717-01000	WASHER WITH RUBBER	2				0.001	0.0022
140	31351-28210	CAM BRAKE	2				0.35	0.77
150	37150-28224	LEVER BRAKE CAM RH	1				0.32	0.704
160	37150-28234	LEVER BRAKE CAM LH	1				0.3	0.66
170	04816-00220	O RING	4				0.003	0.0066
180	04015-60120	WASHER PLAIN	2				0.022	0.0484
190	04512-60120	WASHER SPRING	2				0.005	0.011
200	02174-50120	NUT	2				0.01	0.022
210	37150-28240	PLATE CAM LH	1				1.13	2.486
220	37150-28270	PLATE CAM RH	1				1.08	2.376
230	37150-28250	SEAT BALL	12				0.003	0.0066
240	07715-00805	BALL	12				0.016	0.0352
250	T1060-28200	DISK BRAKE MAIN	4				0.75	1.65
260	37720-28170	PLATE	2				0.342	0.7524

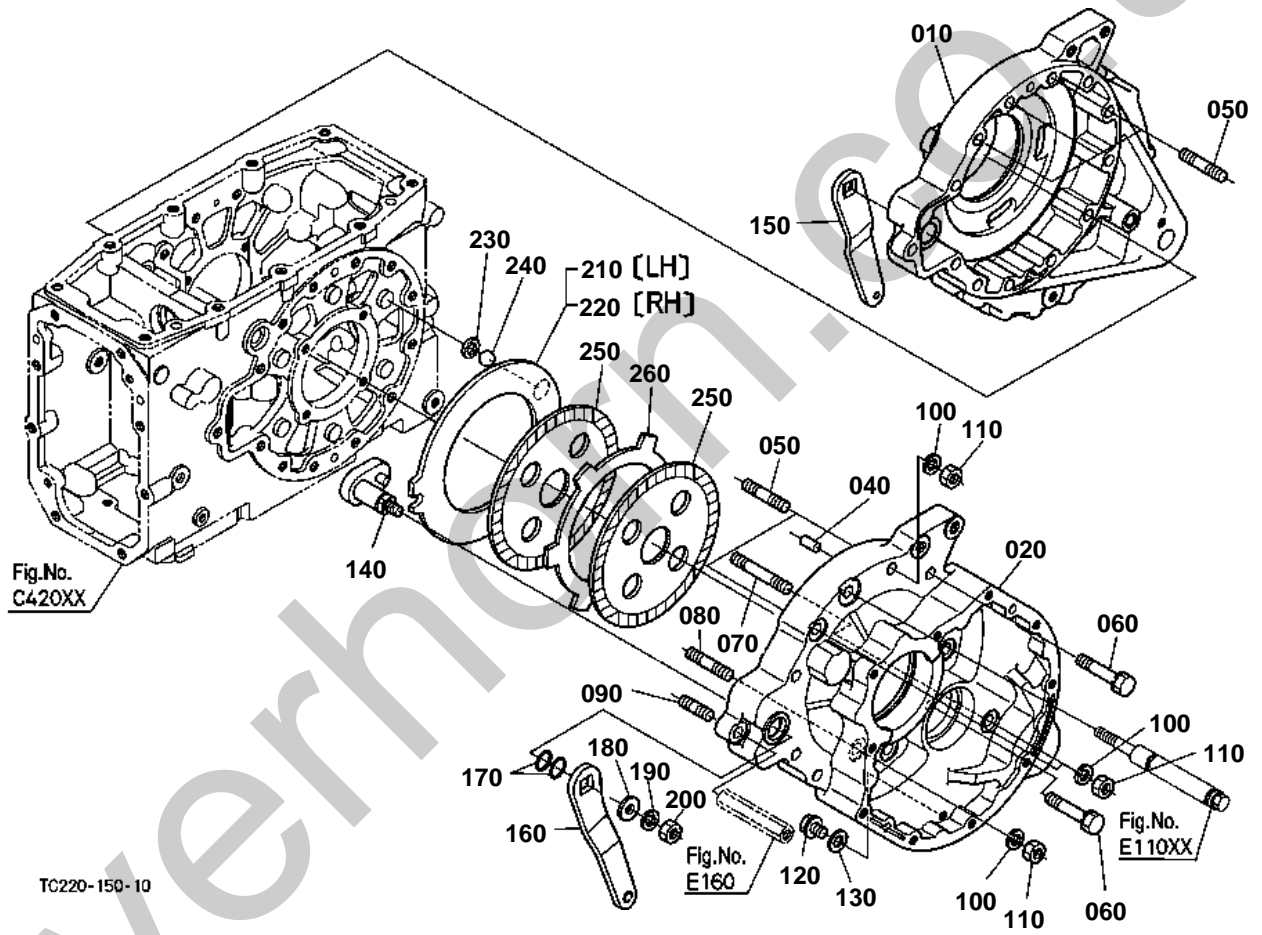

TC220-150-10



**BRAKE [HST TYPE]**

↔ Interchangeable; ≠ not interchangeable; ← new for old; → old for new

REF.No	Part No.	Description	Q'ty	S.No.	I/C	REMARKS	Weight (kgf)	Weight (lb)
010	TC220-28134	CASE BRAKE RH	1				17.8	39.16
020	TC220-28154	CASE BRAKE LH	1				17.8	39.16
030	99999-99999	BLANK	0				0	0
040	05012-01018	PIN STRAIGHT	4				0.012	0.0264
050	37150-27350	STUD	5				0.06	0.132
060	01133-51260	BOLT	10				0.06	0.132
070	01574-51280	STUD	2				0.08	0.176
080	01574-61260	STUD	8				0.05	0.11
090	01574-61235	STUD	2				0.04	0.088
100	04512-60120	WASHER SPRING	16				0.005	0.011
110	02176-50120	NUT	16				0.01	0.022
120	06331-45010	PLUG	2				0.02	0.044
130	04717-01000	WASHER WITH RUBBER	2				0.001	0.0022
140	31351-28210	CAM BRAKE	2				0.35	0.77
150	37150-28224	LEVER BRAKE CAM RH	1				0.32	0.704
160	37150-28234	LEVER BRAKE CAM LH	1				0.3	0.66
170	04816-00220	O RING	4				0.003	0.0066
180	04015-60120	WASHER PLAIN	2				0.022	0.0484
190	04512-60120	WASHER SPRING	2				0.005	0.011
200	02174-50120	NUT	2				0.01	0.022
210	37150-28240	PLATE CAM LH	1				1.13	2.486
220	37150-28270	PLATE CAM RH	1				1.08	2.376
230	37150-28250	SEAT BALL	12				0.003	0.0066
240	07715-00805	BALL	12				0.016	0.0352
250	T1060-28200	DISK BRAKE MAIN	4				0.75	1.65
260	37720-28170	PLATE	2				0.342	0.7524

BRAKE PEDAL [EXCEPT HST TYPE]

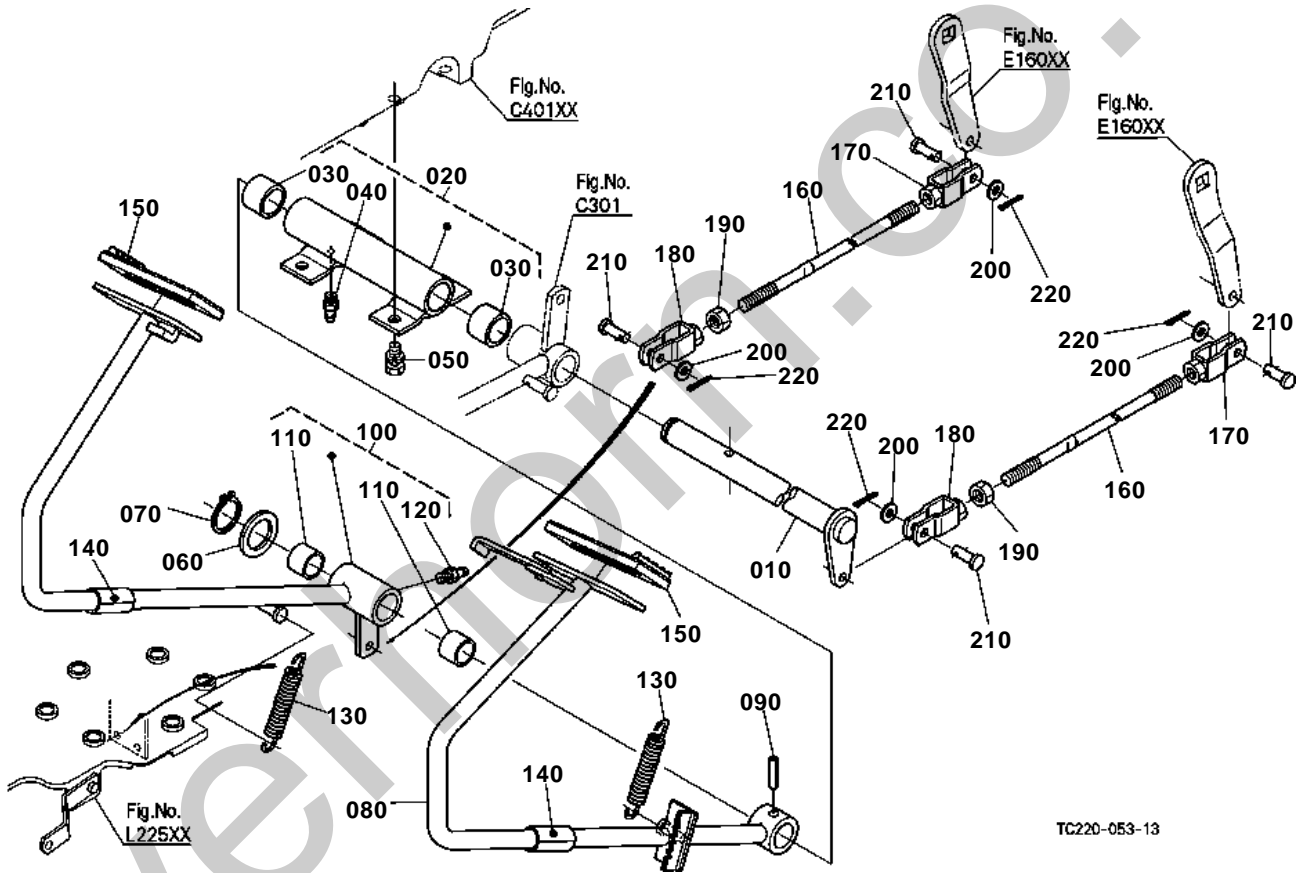

TC220-053-13

**BRAKE PEDAL [EXCEPT HST TYPE]**

↔ Interchangeable; ≠ not interchangeable; ← new for old; → old for new

REF.No	Part No.	Description	Q'ty	S.No.	I/C	REMARKS	Weight (kgf)	Weight (lb)
010	TC220-28410	SHAFT BRAKE PEDAL	1				1.43	3.146
020	TC220-28440	ASSY SUPPORT SHAFT	1				0.22	0.484
030	34150-28430	BUSH	2				0.04	0.088
040	06613-10675	NIPPLE GREASE	1				0.003	0.0066
050	01133-51020	BOLT	4				0.02	0.044
060	32150-28460	COLLAR	1				0.007	0.0154
070	04612-00250	CIR CLIP EXTERNAL	1				0.002	0.0044
080	TC220-28610	PEDAL BRAKE LH	1				2	4.4
090	05411-00840	PIN SPRING	1				0.008	0.0176
100	TC220-28640	ASSY PEDAL BRAKE RH	1				2.1	4.62
110	08511-02520	BUSH	2				0.02	0.044
120	06613-10675	NIPPLE GREASE	1				0.003	0.0066
130	37150-15840	SPRING	2				0.06	0.132
140	32400-15830	CUSHION	2				0.005	0.011
150	37410-44120	COVER PEDAL	2	<=52160			0	0
150	T2050-44120	COVER PEDAL	2	>=52161	→		0.07	0.154
160	TC220-28930	ROD BRAKE	2				0.245	0.539
170	TC220-28940	U JOINT	2				0.07	0.154
180	TC220-28950	U JOINT	2				0.07	0.154
190	02172-50120	NUT	2				0.01	0.022
200	04012-50080	WASHER PLAIN	4				0.001	0.0022
210	05122-50822	PIN JOINT	4				0.01	0.022
220	05511-50215	PIN SPLIT	4				0.001	0.0022

BRAKE PEDAL [HST TYPE]

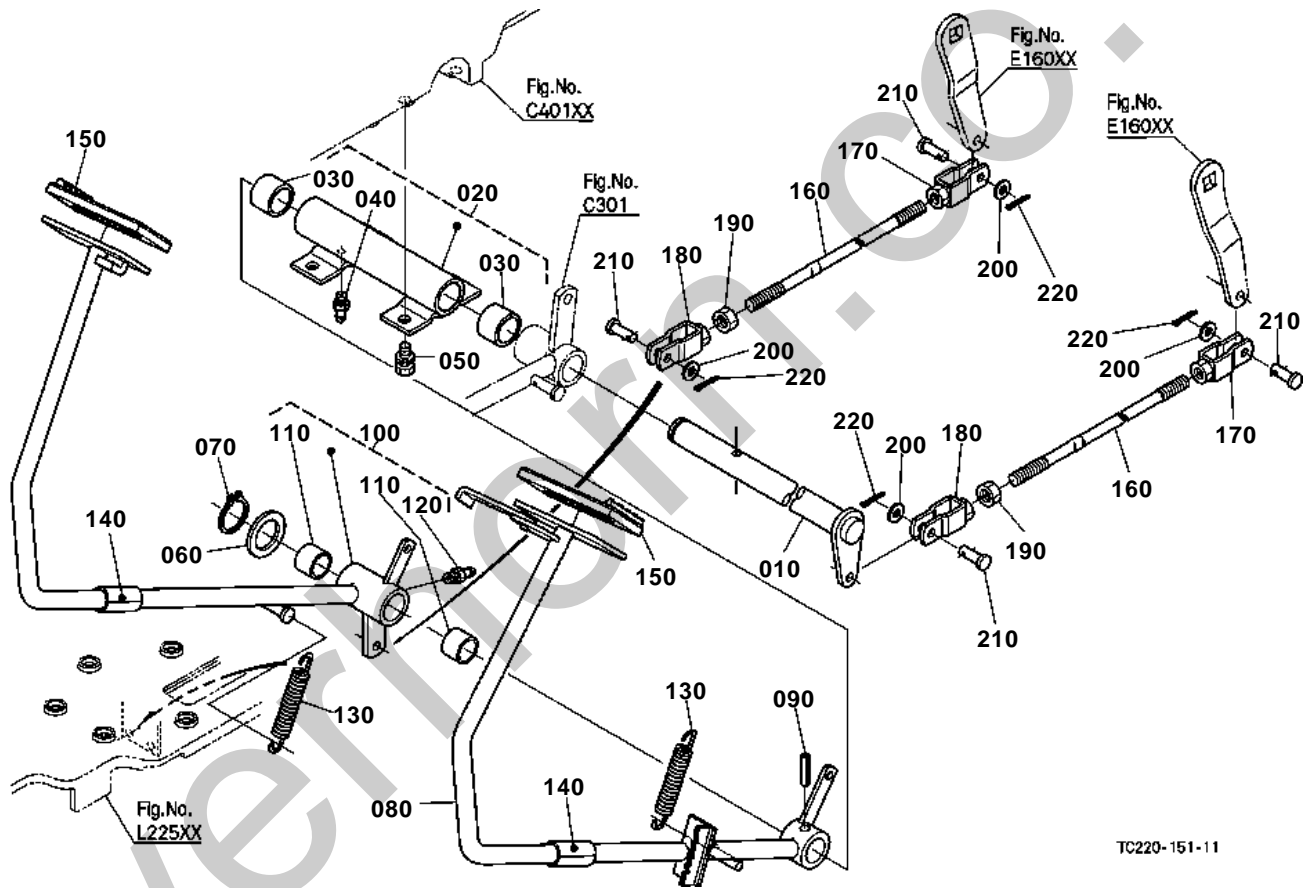

TC220-151-11

**BRAKE PEDAL [HST TYPE]**

↔ Interchangeable; ≠ not interchangeable; ← new for old; → old for new

REF.No	Part No.	Description	Q'ty	S.No.	I/C	REMARKS	Weight (kgf)	Weight (lb)
010	TC220-28410	SHAFT BRAKE PEDAL	1				1.43	3.146
020	TC220-28440	ASSY SUPPORT SHAFT	1				0.22	0.484
030	34150-28430	BUSH	2				0.04	0.088
040	06613-10675	NIPPLE GREASE	1				0.003	0.0066
050	01133-51020	BOLT	4				0.02	0.044
060	32150-28460	COLLAR	1				0.007	0.0154
070	04612-00250	CIR CLIP EXTERNAL	1				0.002	0.0044
080	TC220-57392	PEDAL BRAKE LH	1				2.1	4.62
090	05411-00840	PIN SPRING	1				0.008	0.0176
100	TC220-57363	ASSY PEDAL BRAKE RH	1				2.1	4.62
110	08511-02520	BUSH	2				0.02	0.044
120	06613-10675	NIPPLE GREASE	1				0.003	0.0066
130	37150-15840	SPRING	2				0.06	0.132
140	32400-15830	CUSHION	2				0.005	0.011
150	T2050-44120	COVER PEDAL	2				0.07	0.154
160	TC220-28930	ROD BRAKE	2				0.245	0.539
170	TC220-28940	U JOINT	2				0.07	0.154
180	TC220-28950	U JOINT	2				0.07	0.154
190	02172-50120	NUT	2				0.01	0.022
200	04012-50080	WASHER PLAIN	4				0.001	0.0022
210	05122-50822	PIN JOINT	4				0.01	0.022
220	05511-50215	PIN SPLIT	4				0.001	0.0022

PARKING BRAKE LEVER

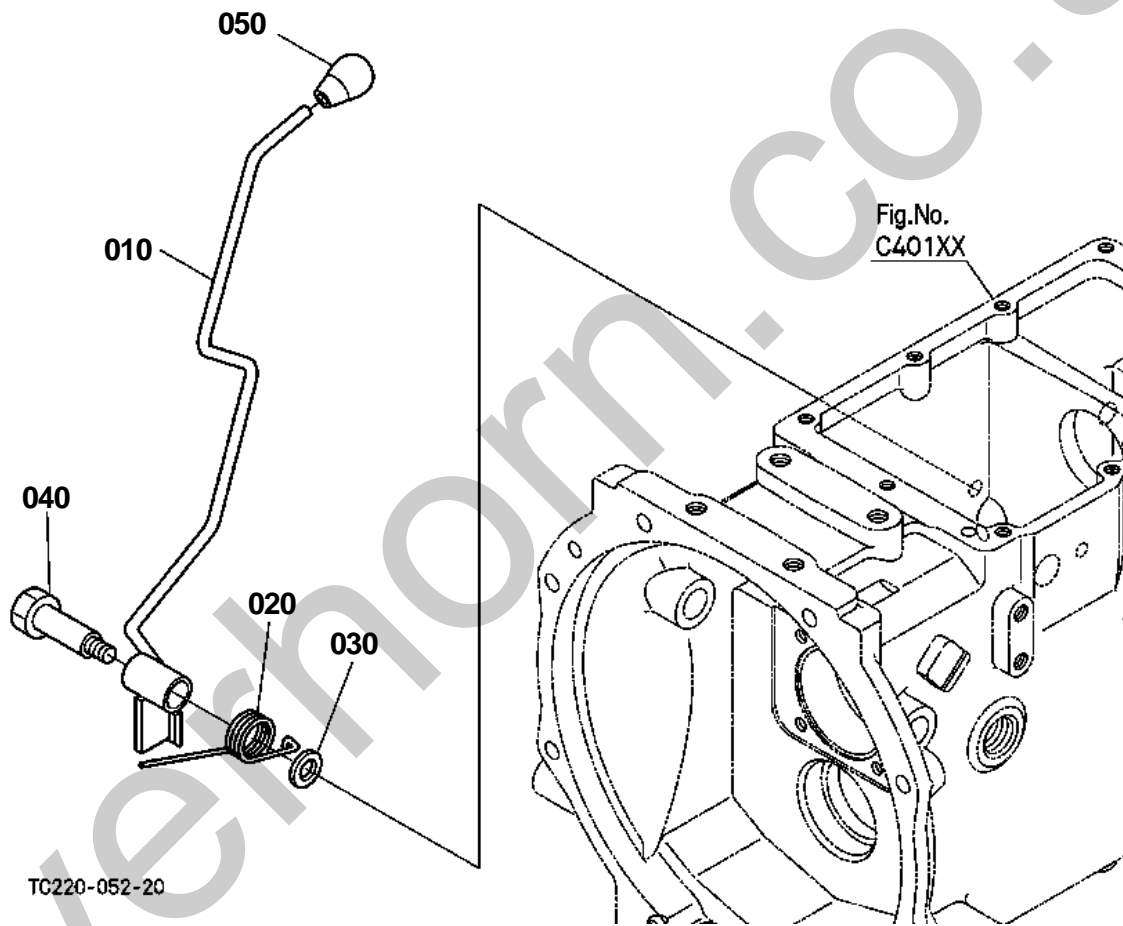



## PARKING BRAKE LEVER

↔ Interchangeable; ≠ not interchangeable; ← new for old; → old for new

REF.No	Part No.	Description	Q'ty	S.No.	I/C	REMARKS	Weight (kgf)	Weight (lb)
010	TC220-28810	LEVER BRAKE	1				0.26	0.572
020	TC220-28850	SPRING	1				0.014	0.0308
030	04013-60120	WASHER PLAIN	1	<=52262			0.01	0.022
030	04011-50120	WASHER PLAIN	1	>=52263	-		0.005	0.011
040	TC220-28820	BOLT	1				0.1	0.22
050	TC220-28870	GRIP	1				0.003	0.0066

FRONT AXLE FRAME [EXCEPT HST TYPE]

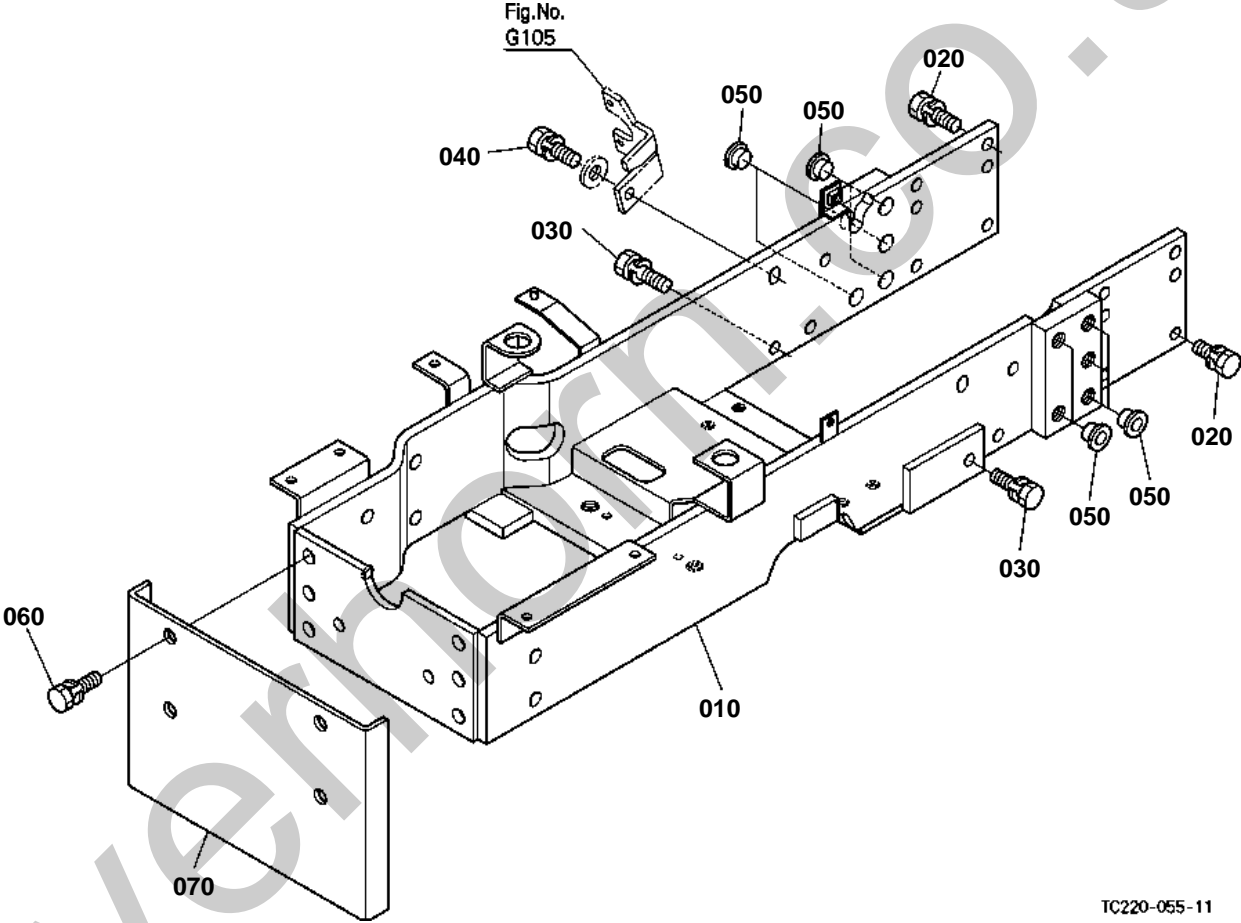

TC220-055-11



OLD PARTS

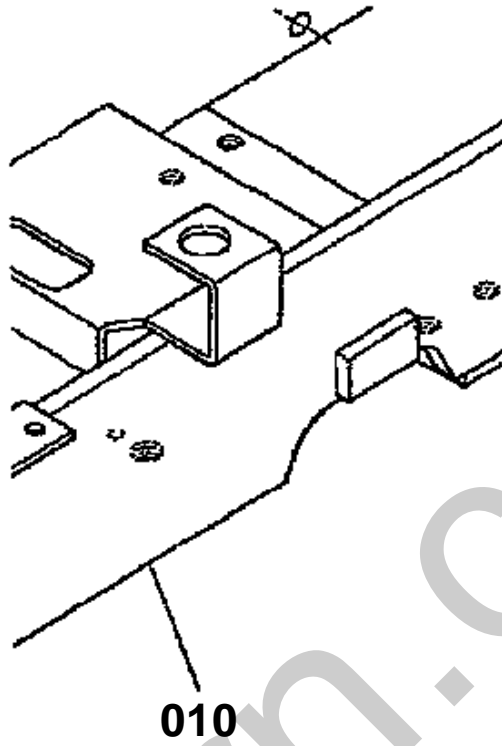

TC220-819-10



## FRONT AXLE FRAME [EXCEPT HST TYPE]

↔ Interchangeable; ≠ not interchangeable; ← new for old; → old for new

REF.No	Part No.	Description	Q'ty	S.No.	I/C	REMARKS	Weight (kgf)	Weight (lb)
010	TC220-14002	COMP.FRAME F-AXLE	1	<=52320			30	66
010	TC220-14003	COMP.FRAME F-AXLE	1	>=52321	-		30	66
020	01133-51230	BOLT	12				0.04	0.088
030	01133-51240	BOLT	2				0.05	0.11
040	01133-51235	BOLT	1				0.043	0.0946
050	33300-90910	PLUG	10				0.002	0.0044
060	01133-51440	BOLT	4				0.07	0.154
070	TC220-13810	BUMPER TIE ROD	1				3.7	8.14

FRONT AXLE FRAME [HST TYPE]

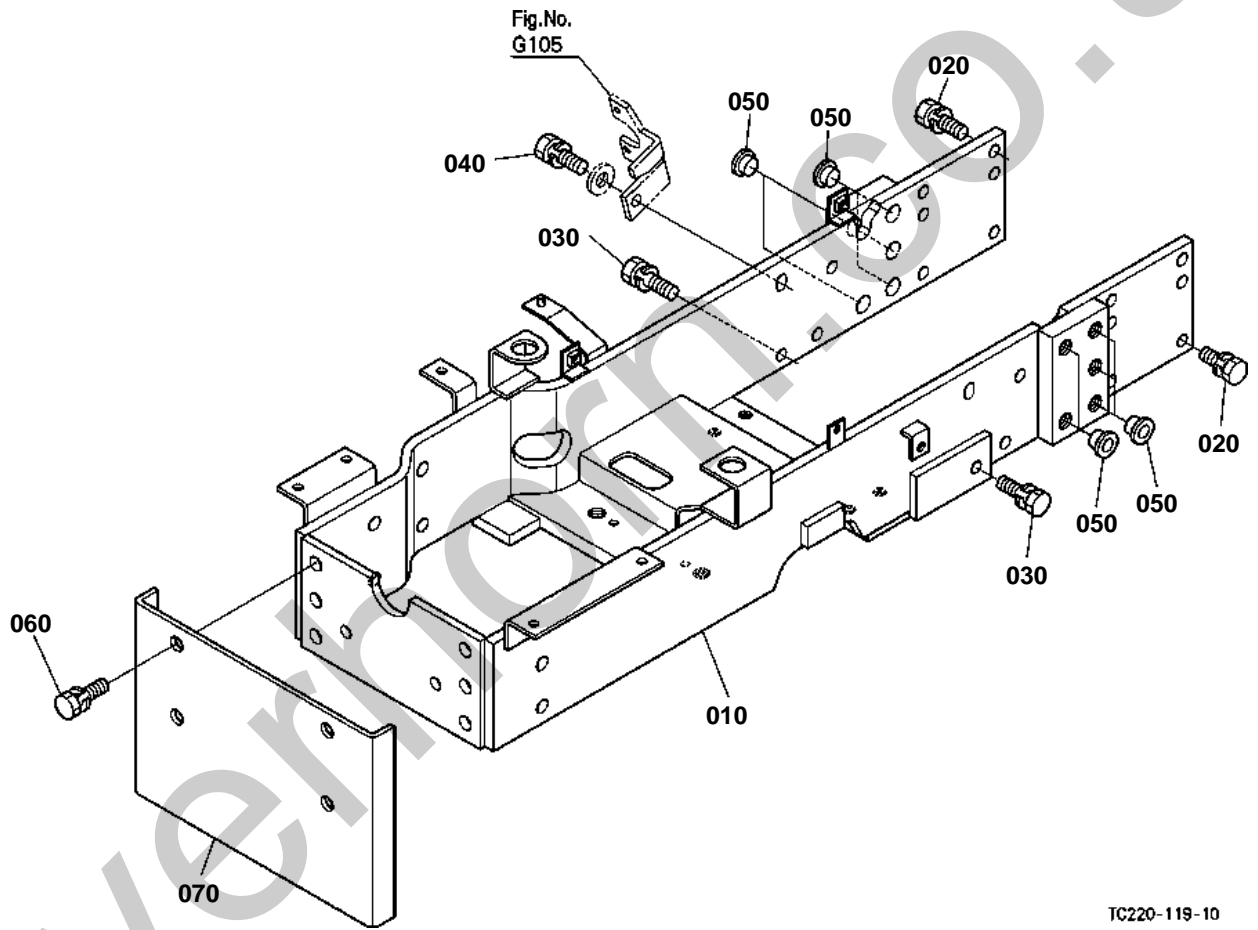

TC220-119-10



# FRONT AXLE FRAME [HST TYPE]

↔ Interchangeable; ≠ not interchangeable; ← new for old; → old for new

REF.No	Part No.	Description	Q'ty	S.No.	I/C	REMARKS	Weight (kgf)	Weight (lb)
010	TC220-54003	COMP.FRAME F-AXLE	1				0	0
020	01133-51230	BOLT	12				0.04	0.088
030	01133-51240	BOLT	2				0.05	0.11
040	01133-51235	BOLT	1				0.043	0.0946
050	33300-90910	PLUG	10				0.002	0.0044
060	01133-51440	BOLT	4				0.07	0.154
070	TC220-13810	BUMPER TIE ROD	1				3.7	8.14

PROPELLER SHAFT

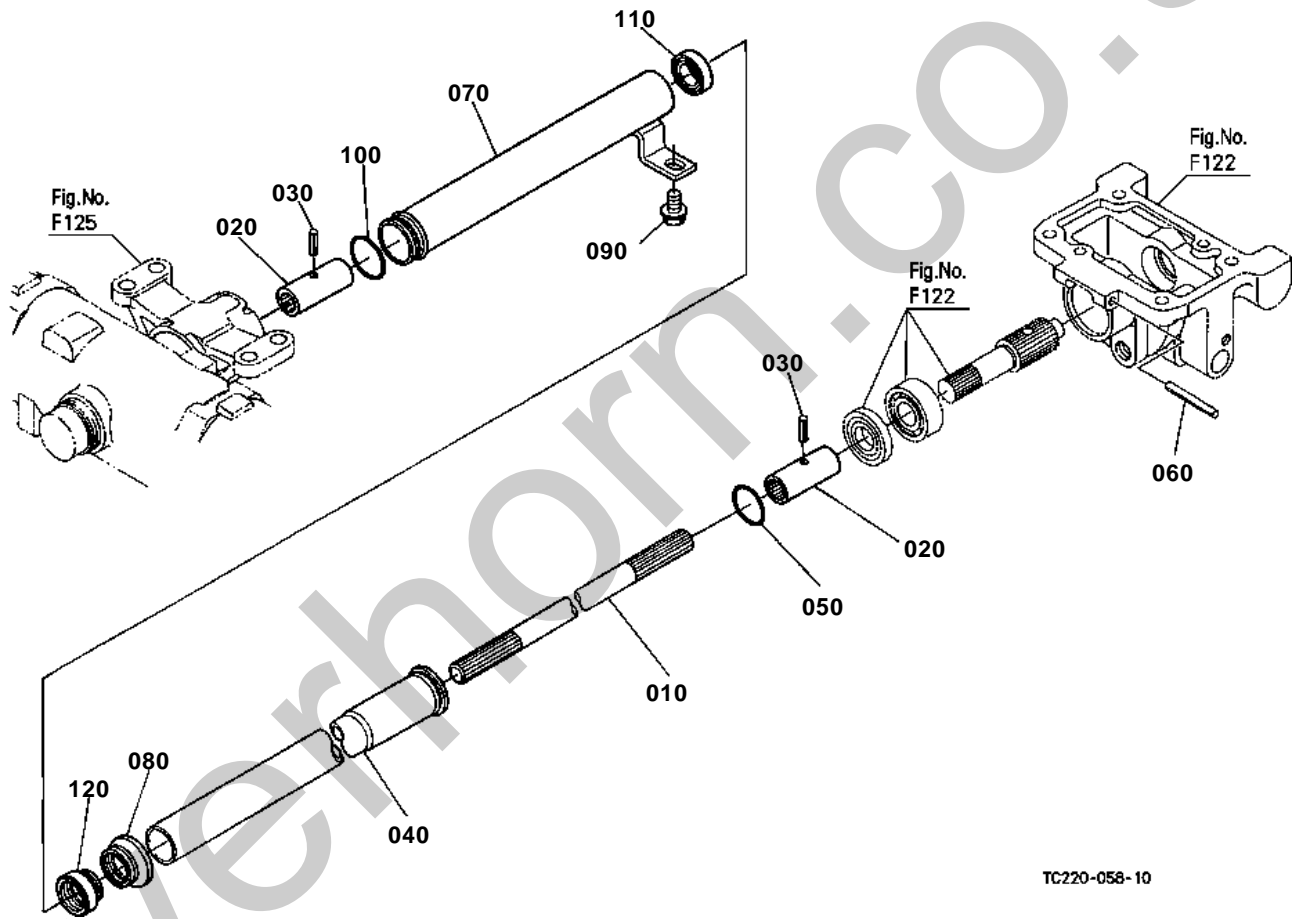

TC220-058-10



# PROPELLER SHAFT

↔ Interchangeable; ≠ not interchangeable; ← new for old; → old for new

REF.No	Part No.	Description	Q'ty	S.No.	I/C	REMARKS	Weight (kgf)	Weight (lb)
010	TC220-14630	SHAFT PROPELLER	1				2.5	5.5
020	T0070-14710	COUPLING	2				0.16	0.352
030	05411-00428	PIN SPRING	2				0.002	0.0044
040	TC220-14580	COVER	1				1.05	2.31
050	04816-00410	O RING	1				0.005	0.011
060	05411-00560	PIN SPRING	1				0.006	0.0132
070	TC220-14570	COVER	1	<=52427			0.41	0.902
070	TC220-14572	COVER	1	>=52428	-		0.41	0.902
080	31353-44570	SEAL	1				0.005	0.011
090	01774-51016	BOLT FLANGE	1				0.02	0.044
100	04811-10360	O RING	1				0.001	0.0022
110	08141-06904	BEARING BALL	1				0.05	0.11
120	32430-44590	RING OUTER	1				0.01	0.022

FRONT WHEEL DRIVE SHAFT

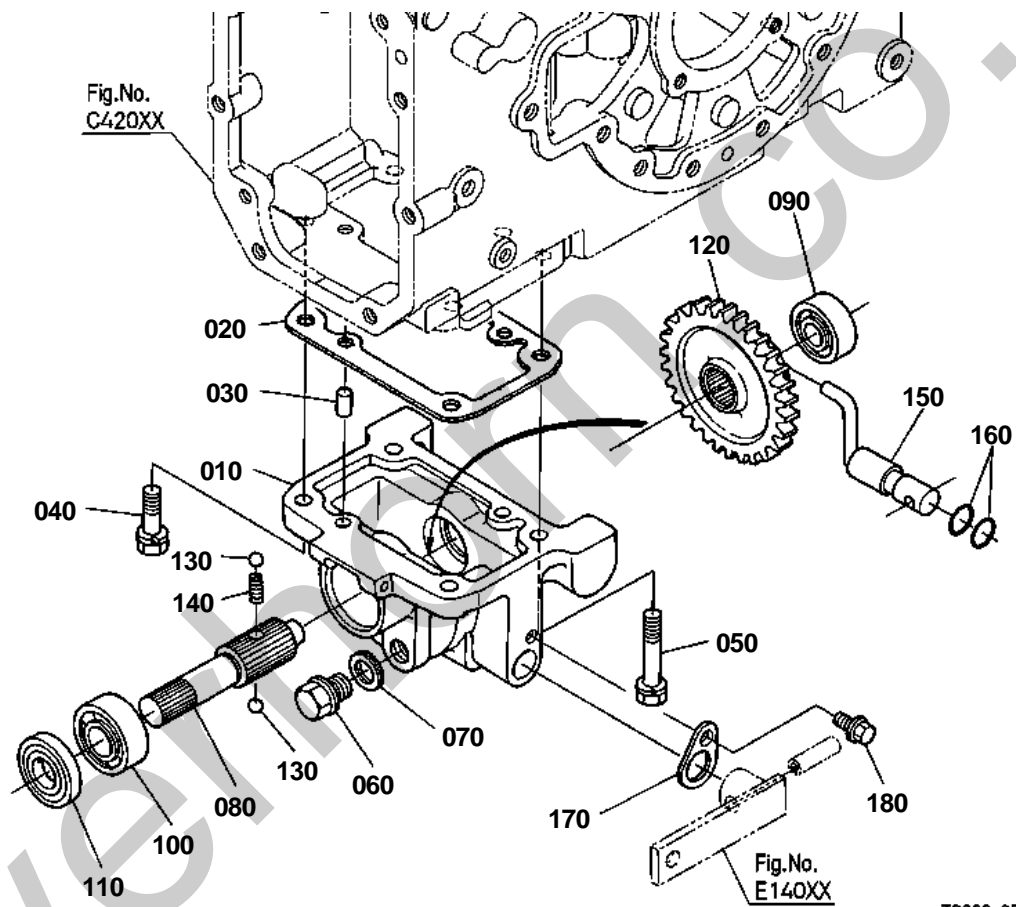

TC220-059-11



# FRONT WHEEL DRIVE SHAFT

↔ Interchangeable; ≠ not interchangeable; ← new for old; → old for new

REF.No	Part No.	Description	Q'ty	S.No.	I/C	REMARKS	Weight (kgf)	Weight (lb)
010	31353-44210	CASE DRIVE	1				0.9	1.98
020	32425-21280	GASKET NA	1				0.01	0.022
030	05012-01018	PIN STRAIGHT	2				0.012	0.0264
040	01133-51235	BOLT	2				0.043	0.0946
050	01133-51260	BOLT	2				0.06	0.132
060	15512-96010	PLUG DRAIN	1				0.101	0.2222
070	04717-02150	WASHER WITH RUBBER	1				0.004	0.0088
080	31353-44220	SHAFT	1				0.375	0.825
090	08101-06203	BEARING BALL	1				0.063	0.1386
100	08101-06204	BEARING BALL	1				0.102	0.2244
110	09502-04710	SEAL OIL	1				0.022	0.0484
120	31343-44230	GEAR SHIFT	1			33T	0.565	1.243
130	07715-01605	BALL	2				0.003	0.0066
140	31353-44250	SPRING	1				0.015	0.033
150	31353-44310	LEVER SHIFT	1				0.16	0.352
160	04816-00150	O RING	2				0.003	0.0066
170	31353-44330	STOPPER LEVER	1				0.01	0.022
180	01754-50816	BOLT FLANGE	1				0.011	0.0242



FRONT DIFFERENTIAL CASE

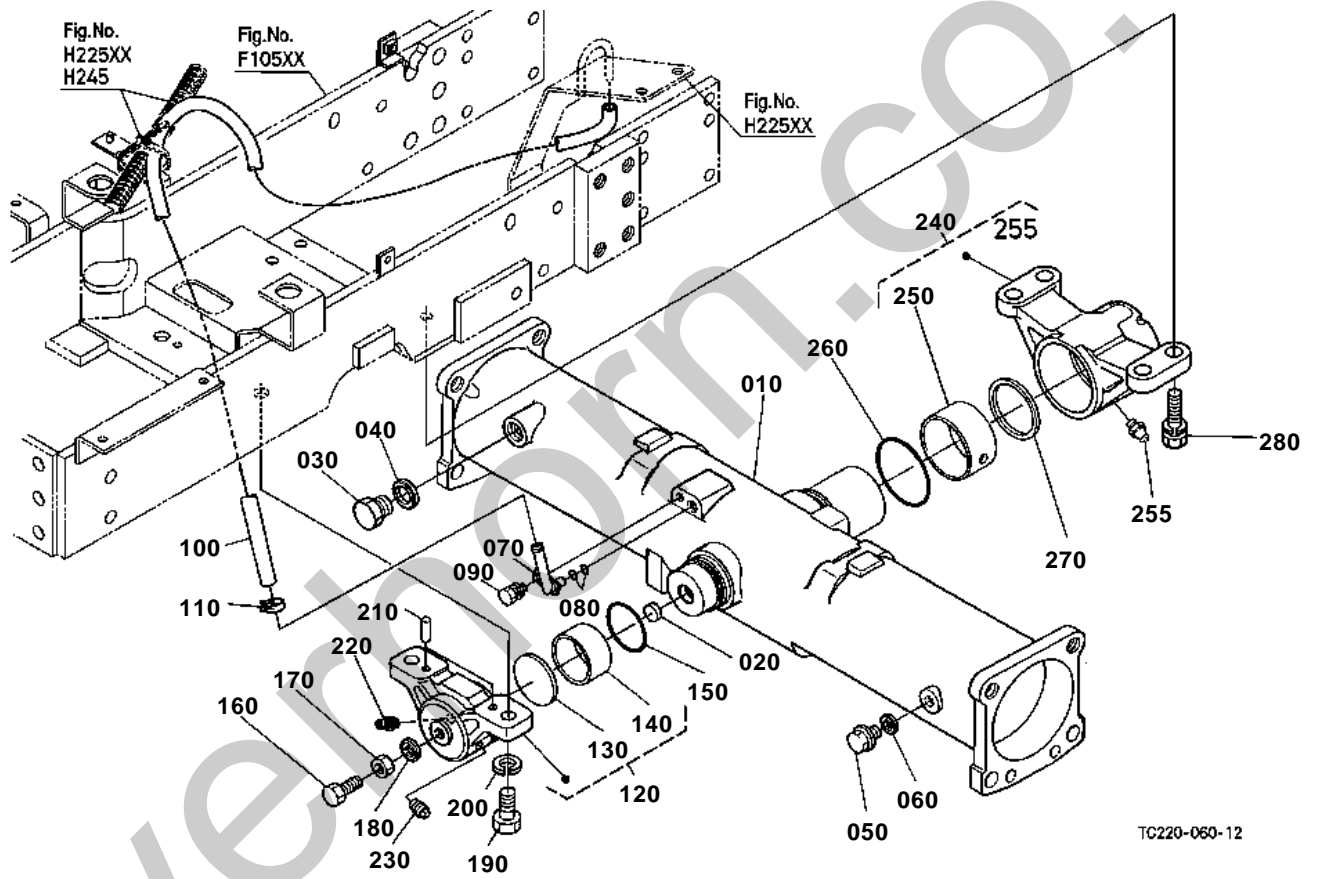



## FRONT DIFFERENTIAL CASE

↔ Interchangeable; ≠ not interchangeable; ← new for old; → old for new

REF.No	Part No.	Description	Q'ty	S.No.	I/C	REMARKS	Weight (kgf)	Weight (lb)
010	TA020-12003	CASE FRONT AXLE	1				19	41.8
020	31321-38720	PLUG	1				0.005	0.011
030	06331-35020	PLUG	1				0.068	0.1496
040	04717-02000	WASHER WITH RUBBER	1				0.004	0.0088
050	06331-45010	PLUG	1				0.02	0.044
060	04717-01000	WASHER WITH RUBBER	1				0.001	0.0022
070	TA040-12910	PIPE BREATHER	1				0.017	0.0374
080	04816-00080	O RING	2				0.002	0.0044
090	01123-60814	BOLT	1				0.01	0.022
100	09663-80725	TUBE FUEL	1				0.08	0.176
110	09318-88115	CLAMP HOSE	1				0.002	0.0044
120	TA140-13553	ASSY HOLDER FRONT	1				1.485	3.267
130	37410-56180	COLLAR THRUST	1				0.06	0.132
140	08511-05020	BUSH	1				0.06	0.132
150	04816-00490	O RING	1				0.005	0.011
160	01173-51030	BOLT	1				0.023	0.0506
170	02118-50100	NUT	1				0.005	0.011
180	31351-16250	WASHER SEAL	1				0.015	0.033
190	TA040-13570	BOLT	2				0.08	0.176
200	04512-60160	WASHER SPRING	2				0.01	0.022
210	05012-00818	PIN STRAIGHT	2				0.013	0.0286
220	06613-10010	NIPPLE GREASE	1				0.006	0.0132
230	06312-10010	PLUG	1				0.007	0.0154
240	TC220-13600	ASSY HOLDER REAR	1	<=51027			2.6	5.72
240	TC220-13602	ASSY HOLDER REAR	1	>=51028	-		2.6	5.72
250	TA140-13640	BUSH	1				0.09	0.198
255	06613-10010	NIPPLE GREASE	1				0.006	0.0132
260	04811-50700	O RING	1				0.002	0.0044
270	34070-13620	COLLAR THRUST	1				0.05	0.11
280	01133-51230	BOLT	4				0.04	0.088

FRONT DIFFERENTIAL

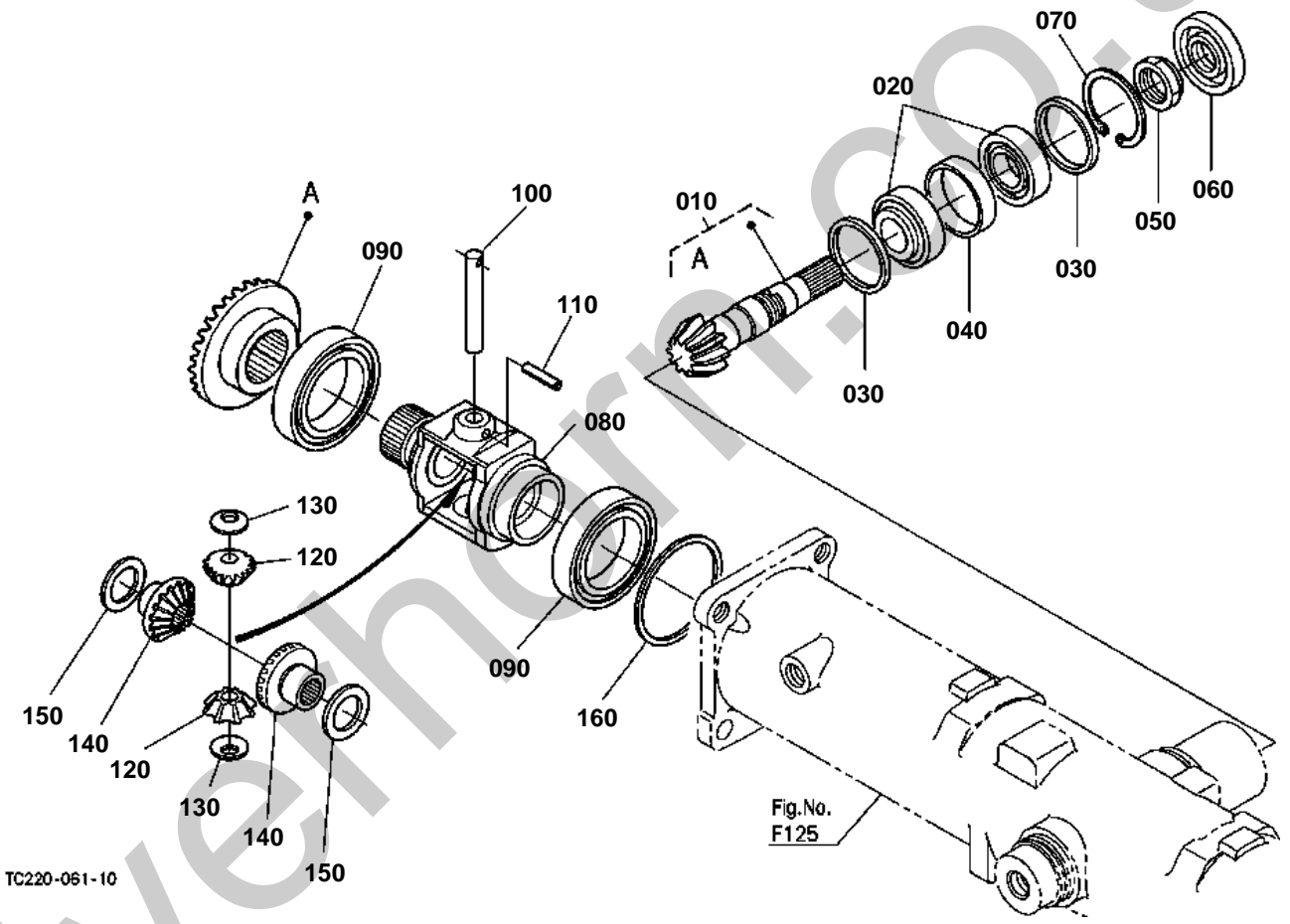

Fig.No. F125



## FRONT DIFFERENTIAL

↔ Interchangeable; ≠ not interchangeable; ← new for old; → old for new

REF.No	Part No.	Description	Q'ty	S.No.	I/C	REMARKS	Weight (kgf)	Weight (lb)
010	TA020-12013	ASSY GEAR BEVEL	1			9-23T	1.95	4.29
020	34070-12200	BEARING TAPER-ROLLER	2				0.305	0.671
030	34070-12060	COLLAR	2			5.8mm	0.015	0.033
030	34070-12070	COLLAR	2			5.9mm	0.015	0.033
030	34070-12080	COLLAR	2			6.0mm	0.015	0.033
030	34070-12090	COLLAR	2			6.1mm	0.015	0.033
030	34070-12100	COLLAR	2			6.2mm	0.02	0.044
040	34070-12130	COLLAR	1			9.8mm	0.03	0.066
040	34070-12140	COLLAR	1			9.9mm	0.02	0.044
040	3A221-43100	COLLAR	1			10.0mm	0.025	0.055
040	34070-12160	COLLAR	1			10.1mm	0.03	0.066
040	34070-12170	COLLAR	1			10.2mm	0.03	0.066
050	37410-56710	NUT	1				0.03	0.066
060	34070-12220	SEAL OIL	1				0.03	0.066
070	04611-00580	CIR CLIP INTERNAL	1				0.005	0.011
080	TC220-12250	CASE DIFFERENTIAL	1				1.63	3.586
090	08101-06212	BEARING BALL	2				0.78	1.716
100	31353-43333	SHAFT PINION	1				0.13	0.286
110	05411-00630	PIN SPRING	1				0.004	0.0088
120	31353-43343	PINION DIFF.	2			12T	0.1	0.22
130	67121-56670	COLLAR PINION THRUST	2				0.006	0.0132
140	31353-43353	GEAR DIFF.SIDE	2			24T	0.19	0.418
150	67211-15160	SHIM	2			1.0mm	0.01	0.022
150	67211-15170	SHIM	2			0.8mm	0.008	0.0176
150	67211-15180	SHIM	2			1.2mm	0.01	0.022
150	31353-43360	SHIM	2			0.6mm	0.01	0.022
150	31353-43370	SHIM	2			0.4mm	0.01	0.022
160	34070-12300	SHIM	1			1.6mm	0.02	0.044
160	34070-12310	SHIM	1			1.8mm	0.03	0.066
160	34070-12320	SHIM	1			2.0mm	0.03	0.066
160	34070-12330	SHIM	1			2.2mm	0.03	0.066
160	34070-12340	SHIM	1			2.4mm	0.035	0.077

FRONT AXLE CASE LH

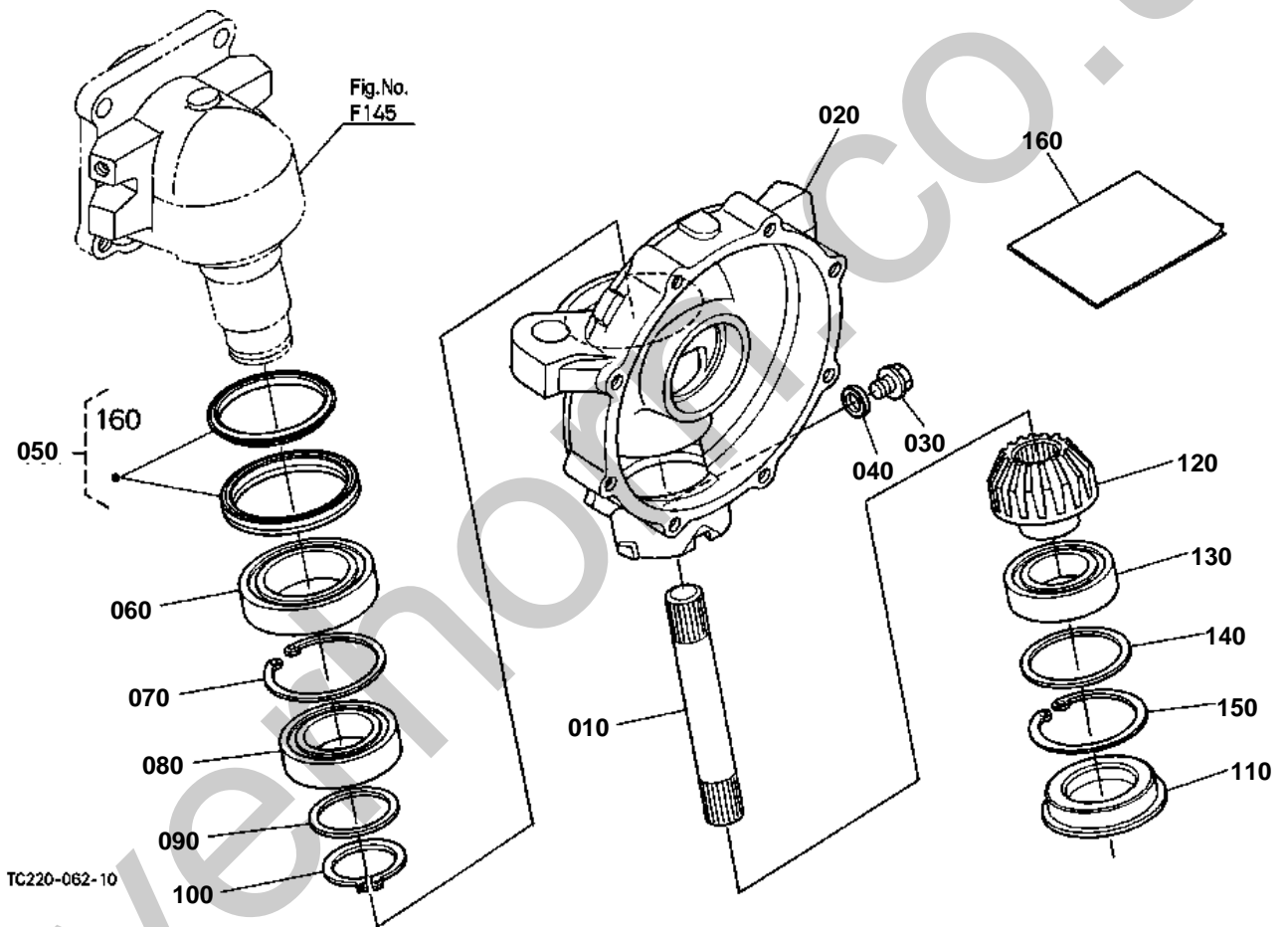



## FRONT AXLE CASE LH

↔ Interchangeable; ≠ not interchangeable; ← new for old; → old for new

REF.No	Part No.	Description	Q'ty	S.No.	I/C	REMARKS	Weight (kgf)	Weight (lb)
010	34070-12720	SHAFT BEVEL GEAR	1				0.63	1.386
020	TC220-13020	CASE FRONT GEAR LH	1				6.4	14.08
030	06331-45010	PLUG	1				0.02	0.044
040	04717-01000	WASHER WITH RUBBER	1				0.001	0.0022
050	TC010-99600	ASSY SEAL OIL	1				0.12	0.264
060	TD060-12820	BEARING BALL	1				0.405	0.891
070	04611-00800	CIR CLIP INTERNAL	1				0.02	0.044
080	TD030-12820	BEARING BALL	1				0.265	0.583
090	TA140-12080	SHIM	1			0.8mm	0.007	0.0154
090	TA140-12100	SHIM	1			1.0mm	0.008	0.0176
090	TA140-12120	SHIM	1			1.2mm	0.01	0.022
090	TA140-12140	SHIM	1			1.4mm	0.011	0.0242
090	TA140-12160	SHIM	1			1.6mm	0.013	0.0286
100	04612-00500	CIR CLIP EXTERNAL	1				0.009	0.0198
110	34070-13100	PLUG	1				0.06	0.132
120	TD030-13200	GEAR BEVEL	1			11T	0.475	1.045
130	T2050-23460	BEARING BALL	1				0.28	0.616
140	37410-57160	SHIM	1			1.0mm	0.01	0.022
140	37410-57170	SHIM	1			1.2mm	0.011	0.0242
140	34070-12610	SHIM	1			1.4mm	0.015	0.033
140	34070-12620	SHIM	1			1.6mm	0.015	0.033
140	34070-12630	SHIM	1			1.8mm	0.015	0.033
140	34070-12640	SHIM	1			2.0mm	0.02	0.044
140	34070-12650	SHIM	1			2.2mm	0.02	0.044
150	04611-00720	CIR CLIP INTERNAL	1				0.018	0.0396
160	99999-99999	MANUAL CONSTRUCTION	1				0	0

FRONT AXLE CASE RH

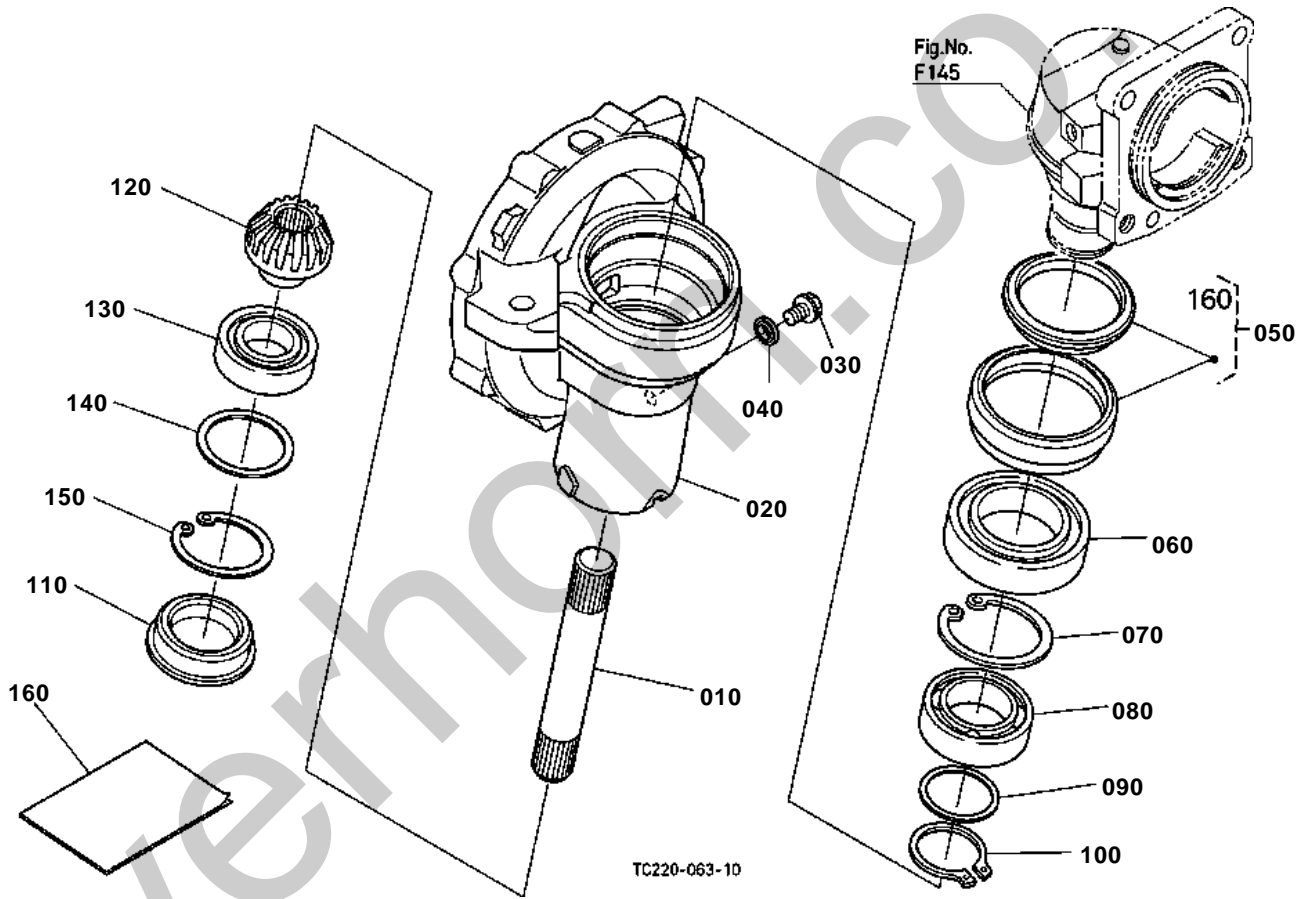



## FRONT AXLE CASE RH

↔ Interchangeable; ≠ not interchangeable; ← new for old; → old for new

REF.No	Part No.	Description	Q'ty	S.No.	I/C	REMARKS	Weight (kgf)	Weight (lb)
010	34070-12720	SHAFT BEVEL GEAR	1				0.63	1.386
020	TC220-13010	CASE FRONT GEAR RH	1				0	0
030	06331-45010	PLUG	1				0.02	0.044
040	04717-01000	WASHER WITH RUBBER	1				0.001	0.0022
050	TC010-99600	ASSY SEAL OIL	1				0.12	0.264
060	TD060-12820	BEARING BALL	1				0.405	0.891
070	04611-00800	CIR CLIP INTERNAL	1				0.02	0.044
080	TD030-12820	BEARING BALL	1				0.265	0.583
090	TA140-12080	SHIM	1			0.8mm	0.007	0.0154
090	TA140-12100	SHIM	1			1.0mm	0.008	0.0176
090	TA140-12120	SHIM	1			1.2mm	0.01	0.022
090	TA140-12140	SHIM	1			1.4mm	0.011	0.0242
090	TA140-12160	SHIM	1			1.6mm	0.013	0.0286
100	04612-00500	CIR CLIP EXTERNAL	1				0.009	0.0198
110	34070-13100	PLUG	1				0.06	0.132
120	TD030-13200	GEAR BEVEL	1			11T	0.475	1.045
130	T2050-23460	BEARING BALL	1				0.28	0.616
140	37410-57160	SHIM	1			1.0mm	0.01	0.022
140	37410-57170	SHIM	1			1.2mm	0.011	0.0242
140	34070-12610	SHIM	1			1.4mm	0.015	0.033
140	34070-12620	SHIM	1			1.6mm	0.015	0.033
140	34070-12630	SHIM	1			1.8mm	0.015	0.033
140	34070-12640	SHIM	1			2.0mm	0.02	0.044
140	34070-12650	SHIM	1			2.2mm	0.02	0.044
150	04611-00720	CIR CLIP INTERNAL	1				0.018	0.0396
160	99999-99999	MANUAL CONSTRUCTION	1				0	0



DIFFERENTIAL GEAR SHAFT

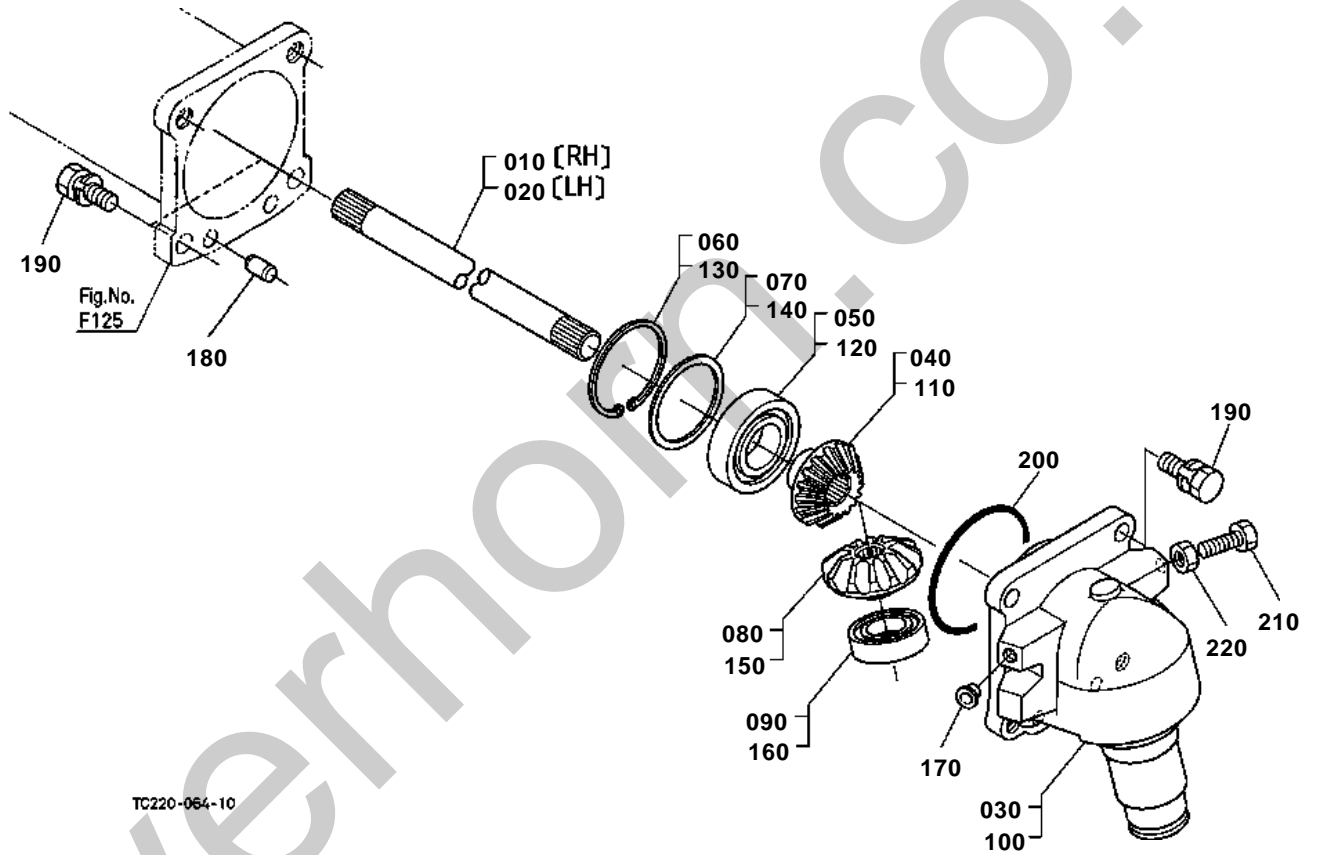

TC220-064-10



## DIFFERENTIAL GEAR SHAFT

↔ Interchangeable; ≠ not interchangeable; ← new for old; → old for new

REF.No	Part No.	Description	Q'ty	S.No.	I/C	REMARKS	Weight (kgf)	Weight (lb)
010	T0040-12450	SHAFT YOKE LH	1			RH	1.69	3.718
020	T0040-12460	SHAFT YOKE RH	1			LH	1.015	2.233
030	TC220-12800	CASE BEVEL GEAR	1				4.2	9.24
040	TA040-12520	GEAR BEVEL	1			11T	0.37	0.814
050	T2050-23460	BEARING BALL	1				0.28	0.616
060	04611-00720	CIR CLIP INTERNAL	1				0.018	0.0396
070	34070-12560	SHIM	1			0.4mm	0.005	0.011
070	34070-12570	SHIM	1			0.6mm	0.005	0.011
070	37410-57150	SHIM	1			0.8mm	0.008	0.0176
070	37410-57160	SHIM	1			1.0mm	0.01	0.022
070	37410-57170	SHIM	1			1.2mm	0.011	0.0242
070	34070-12610	SHIM	1			1.4mm	0.015	0.033
080	TA040-12530	GEAR BEVEL	1			16T	0.67	1.474
090	36920-40090	BEARING BALL	1				0.1	0.22
100	TC220-12800	CASE BEVEL GEAR	1				4.2	9.24
110	TA040-12520	GEAR BEVEL	1			11T	0.37	0.814
120	T2050-23460	BEARING BALL	1				0.28	0.616
130	04611-00720	CIR CLIP INTERNAL	1				0.018	0.0396
140	34070-12560	SHIM	1			0.4mm	0.005	0.011
140	34070-12570	SHIM	1			0.6mm	0.005	0.011
140	37410-57150	SHIM	1			0.8mm	0.008	0.0176
140	37410-57160	SHIM	1			1.0mm	0.01	0.022
140	37410-57170	SHIM	1			1.2mm	0.011	0.0242
140	34070-12610	SHIM	1			1.4mm	0.015	0.033
150	TA040-12530	GEAR BEVEL	1			16T	0.67	1.474
160	36920-40090	BEARING BALL	1				0.1	0.22
170	34150-27580	PLUG	2				0.001	0.0022
180	31353-43880	PIN STRAIGHT	4				0.02	0.044
190	01133-51435	BOLT	8				0.001	0.0022
200	04811-51050	O RING	2				0.003	0.0066
210	01173-51030	BOLT	2				0.023	0.0506
220	02176-50100	NUT	2				0.005	0.011

FRONT AXLE

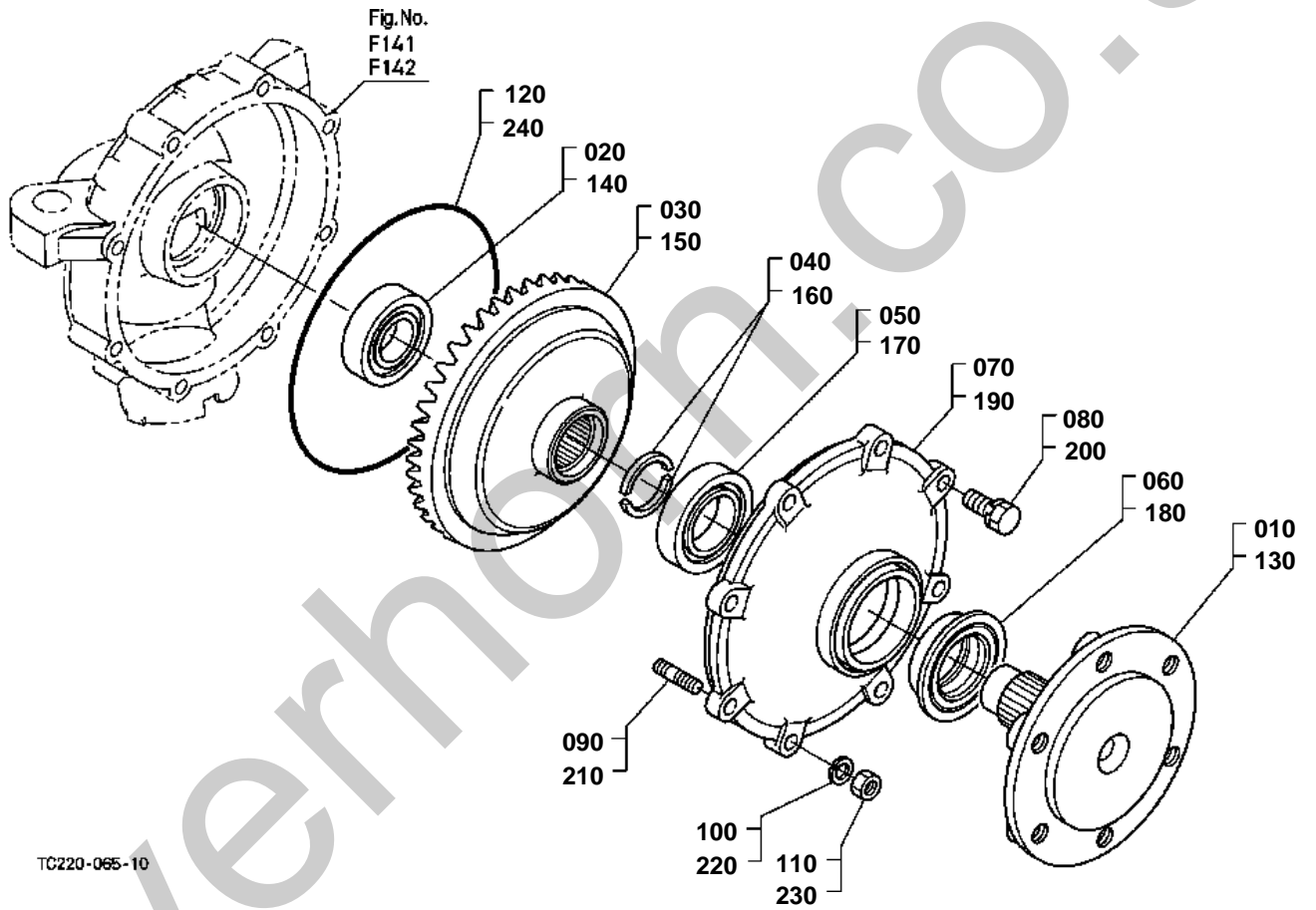



## FRONT AXLE

↔ Interchangeable; ≠ not interchangeable; ← new for old; → old for new

REF.No	Part No.	Description	Q'ty	S.No.	I/C	REMARKS	Weight (kgf)	Weight (lb)
010	34070-13330	AXLE FRONT	1				3.5	7.7
020	TA140-13140	BEARING BALL	1				0.25	0.55
030	34070-13210	GEAR BEVEL	1			42T	5.45	11.99
040	34070-13350	COLLAR	2				0.01	0.022
050	TA140-13150	BEARING BALL	1	<=52160			0	0
050	TD030-13150	BEARING BALL	1	>=52161	-		0.36	0.792
060	34070-13370	SEAL OIL	1				0.1	0.22
070	TA040-13133	COVER FRONT AXLE	1				3.05	6.71
080	01123-50825	BOLT	6				0.013	0.0286
090	01513-60825	STUD	2				0.012	0.0264
100	04512-60080	WASHER SPRING	2				0.002	0.0044
110	02156-50080	NUT	2				0.004	0.0088
120	31353-44130	O RING	1				0.01	0.022
130	34070-13330	AXLE FRONT	1				3.5	7.7
140	TA140-13140	BEARING BALL	1				0.25	0.55
150	34070-13210	GEAR BEVEL	1			42T	5.45	11.99
160	34070-13350	COLLAR	2				0.01	0.022
170	TA140-13150	BEARING BALL	1	<=52160			0	0
170	TD030-13150	BEARING BALL	1	>=52161	-		0.36	0.792
180	34070-13370	SEAL OIL	1				0.1	0.22
190	TA040-13133	COVER FRONT AXLE	1				3.05	6.71
200	01123-50825	BOLT	6				0.013	0.0286
210	01513-60825	STUD	2				0.012	0.0264
220	04512-60080	WASHER SPRING	2				0.002	0.0044
230	02156-50080	NUT	2				0.004	0.0088
240	31353-44130	O RING	1				0.01	0.022

STEERING HANDLE

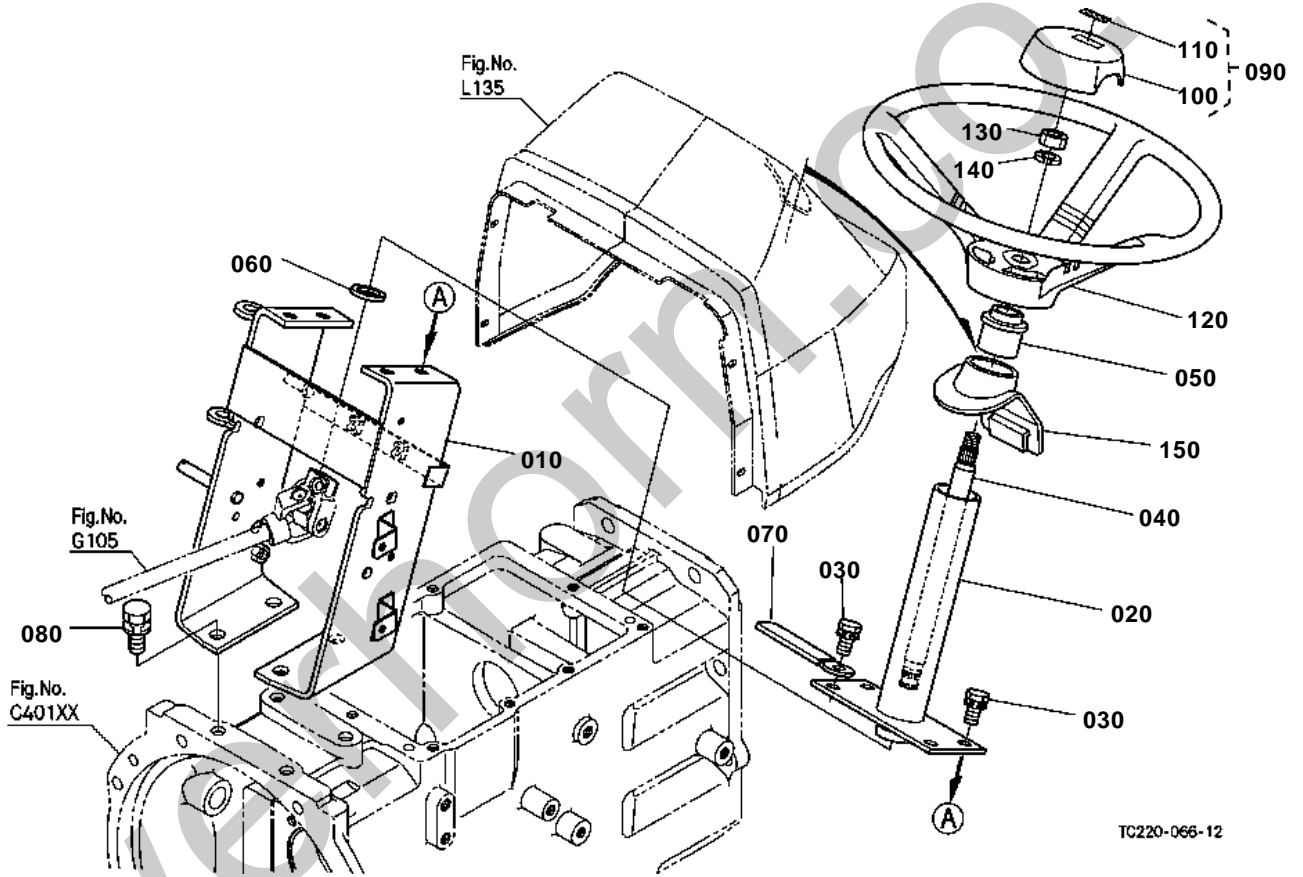

OLD PARTS

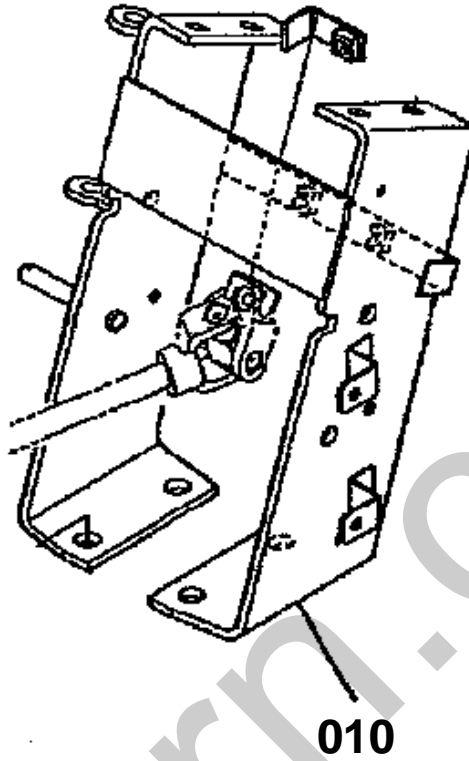

Silverhorn.CO.UK

TC220-820-10



# STEERING HANDLE

↔ Interchangeable; ≠ not interchangeable; ← new for old; → old for new

REF.No	Part No.	Description	Q'ty	S.No.	I/C	REMARKS	Weight (kgf)	Weight (lb)
010	TC220-45682	SUPPORT STEERING	1	<=52262			0	0
010	TC220-45683	SUPPORT STEERING	1	>=52263	-		4.3	9.46
020	TC220-43610	POST STEERING	1				1	2.2
030	01123-50825	BOLT	4				0.013	0.0286
040	TC220-43680	SHAFT STEERING	1				0.5	1.1
050	6C040-41510	BUSH	1				0.035	0.077
060	37410-41320	COLLAR	1				0.005	0.011
070	13824-67580	CLAMP CORD	1				0.006	0.0132
080	01133-51225	BOLT	4				0.035	0.077
090	6C040-41420	ASSY PAD	1				0.041	0.0902
100	6C040-41430	PAD STEERING	1				0.039	0.0858
110	6C040-41440	MARK STEERING	1				0.001	0.0022
120	6C040-41410	WHEEL STEERING	1				1.41	3.102
130	02174-50120	NUT	1				0.01	0.022
140	04512-60120	WASHER SPRING	1				0.005	0.011
150	TC220-16860	COVER	1				0.034	0.0748

UNIVERSAL JOINT

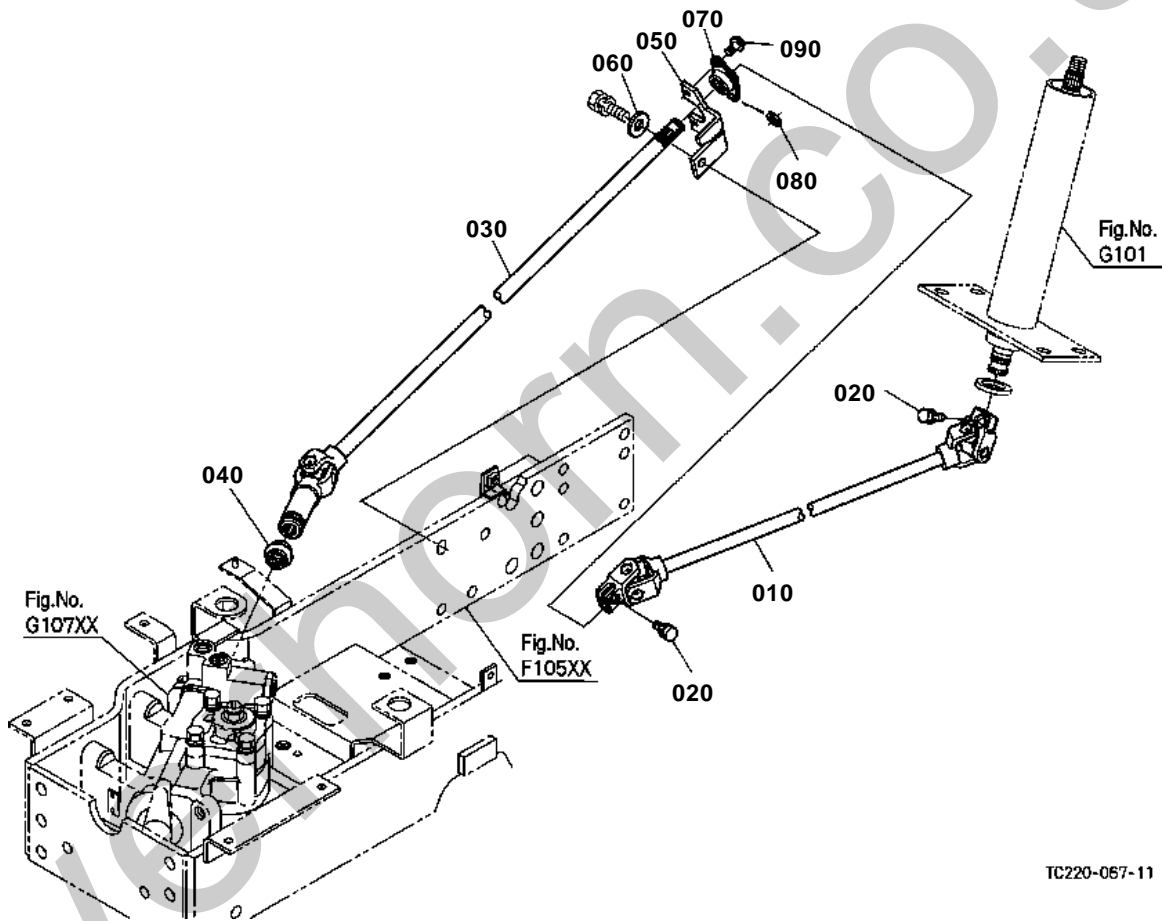

TC220-067-11





# UNIVERSAL JOINT

↔ Interchangeable; ≠ not interchangeable; ← new for old; → old for new

REF.No	Part No.	Description	Q'ty	S.No.	I/C	REMARKS	Weight (kgf)	Weight (lb)
010	TC220-18210	JOINT UNIVERSAL	1				1.08	2.376
020	01123-50825	BOLT	2				0.013	0.0286
030	TC220-18262	JOINT UNIVERSAL	1				1.43	3.146
040	6A100-41640	COVER JOINT	1				0.005	0.011
050	TC220-18280	SUPPORT UJ.	1				0.22	0.484
060	04014-50120	WASHER PLAIN	1				0.007	0.0154
070	34070-43860	BEARING FLANGE	1				0.1	0.22
080	04012-50080	WASHER PLAIN	1				0.001	0.0022
090	01754-50816	BOLT FLANGE	2				0.011	0.0242

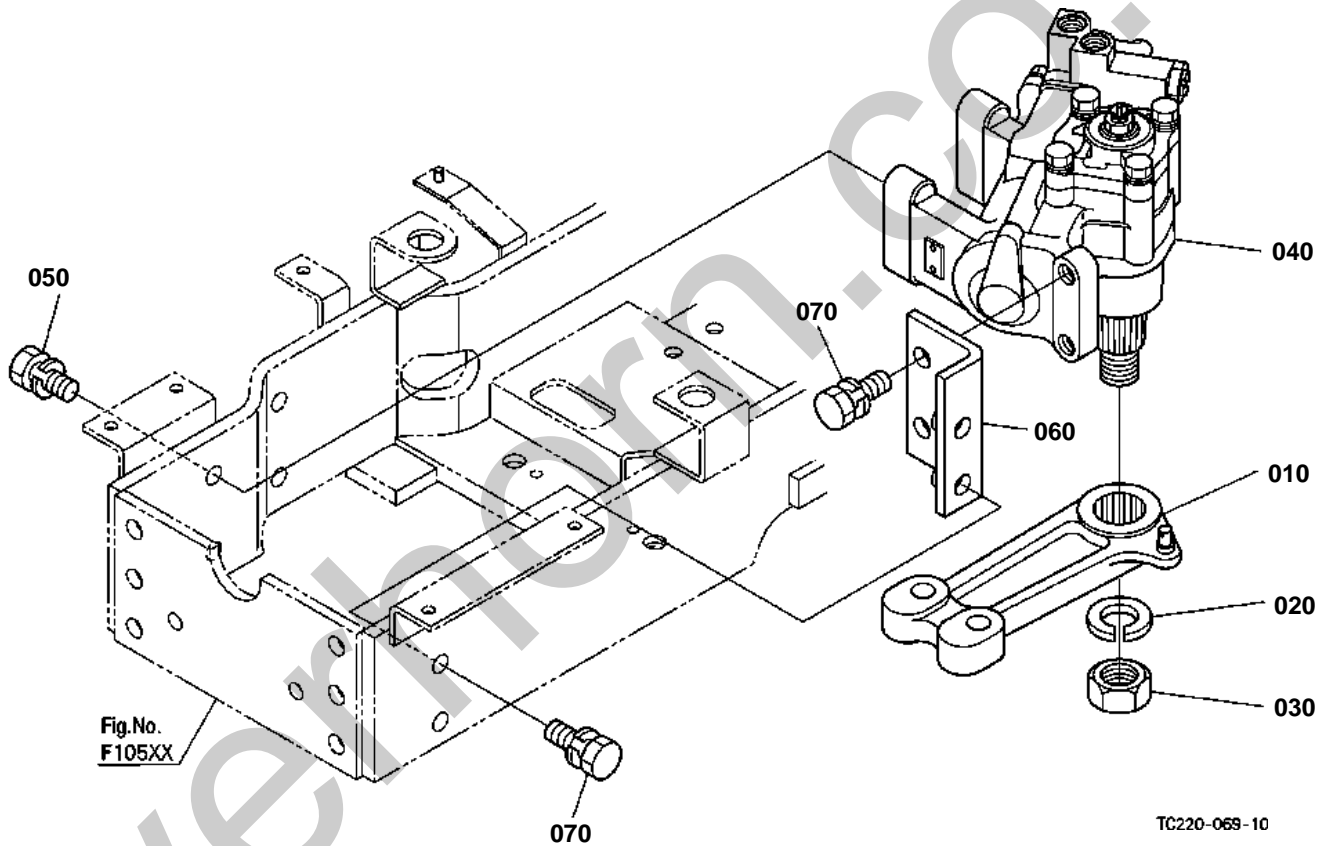

**STEERING**

↔ Interchangeable; ≠ not interchangeable; ← new for old; → old for new

REF.No	Part No.	Description	Q'ty	S.No.	I/C	REMARKS	Weight (kgf)	Weight (lb)
010	T1170-17140	ARM PITMAN	1				1.45	3.19
020	T1060-17190	WASHER SPRING(M)	1				0.045	0.099
030	T1060-17180	NUT	1				0.15	0.33
040	TC220-37000	ASSY STEERING POWER	1				16.1	35.42
050	01133-51430	BOLT	4				0.001	0.0022
060	T1060-17160	SUPPORT POWER STRG.	1				0.91	2.002
070	01133-51435	BOLT	4				0.001	0.0022

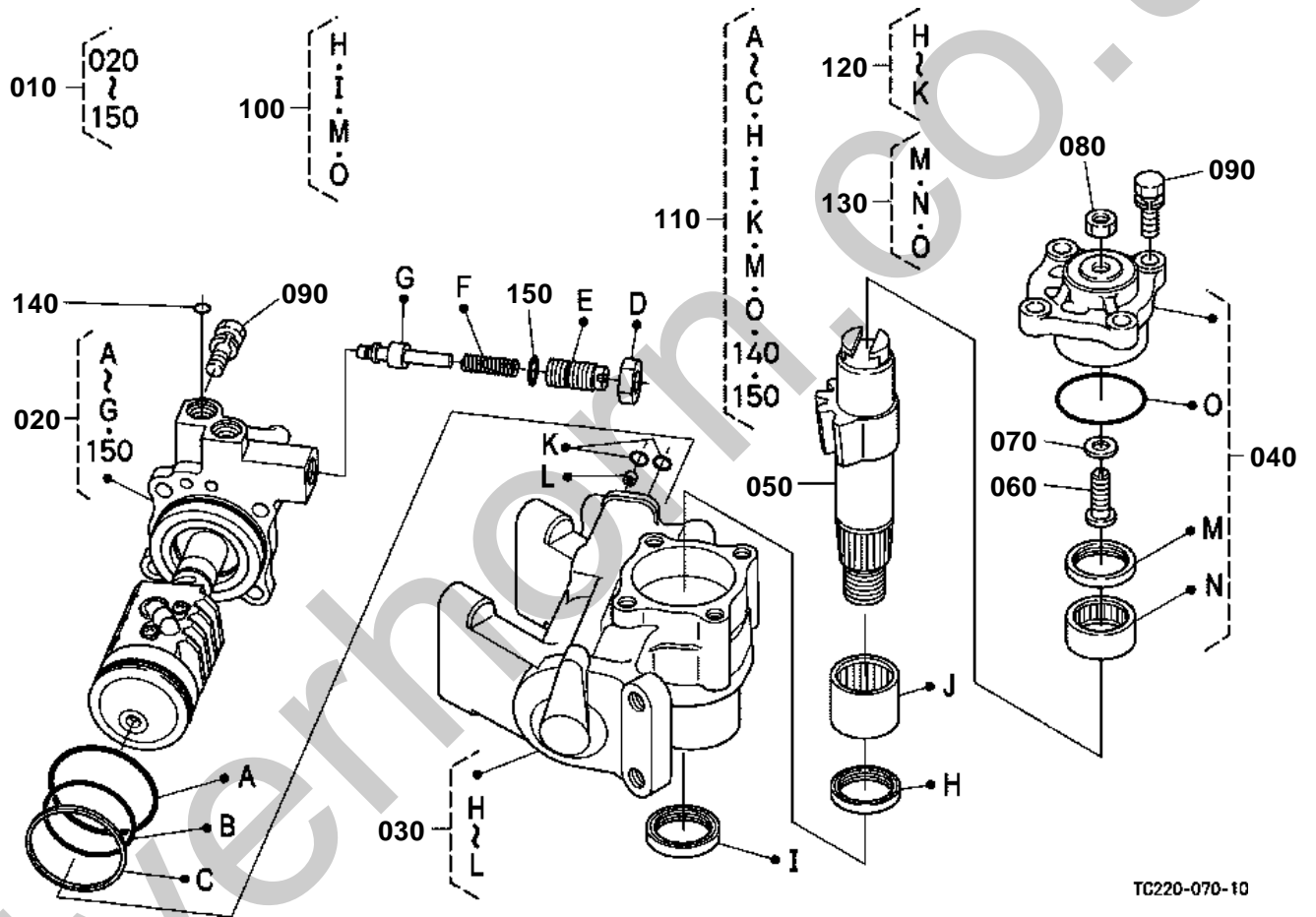



## STEERING [COMPONENT PARTS]

↔ Interchangeable; ≠ not interchangeable; ← new for old; → old for new

REF.No	Part No.	Description	Q'ty	S.No.	I/C	REMARKS	Weight (kgf)	Weight (lb)
010	TC220-37000	ASSY STEERING POWER	1				16.1	35.42
020	TC220-37020	SCREW BALL	1				5	11
030	T1060-37040	BOX GEAR	1				7.6	16.72
040	T1060-37100	CASE SIDE COVER	1				1.175	2.585
050	T1060-37200	SHAFT CROSS	1				1.96	4.312
060	T1060-37120	BOLT ADJUST	1				0.035	0.077
070	T1060-37140	PLATE ADJUST	1				0.02	0.044
080	T1060-37160	NUT ADJUST	1				0.005	0.011
090	T1060-37182	BOLT	8				0.04	0.088
100	T1150-99710	KIT SEAL	1				0.026	0.0572
110	T1150-99720	KIT SEAL	1				0.03	0.066
120	T1150-99730	KIT REPAIR	1				0.115	0.253
130	T1150-99740	KIT REPAIR	1				0.09	0.198
140	T1150-99750	O RING	1				0.001	0.0022
150	T1150-99760	O RING	1				0.001	0.0022

STEERING LINKAGE (TIE ROD)

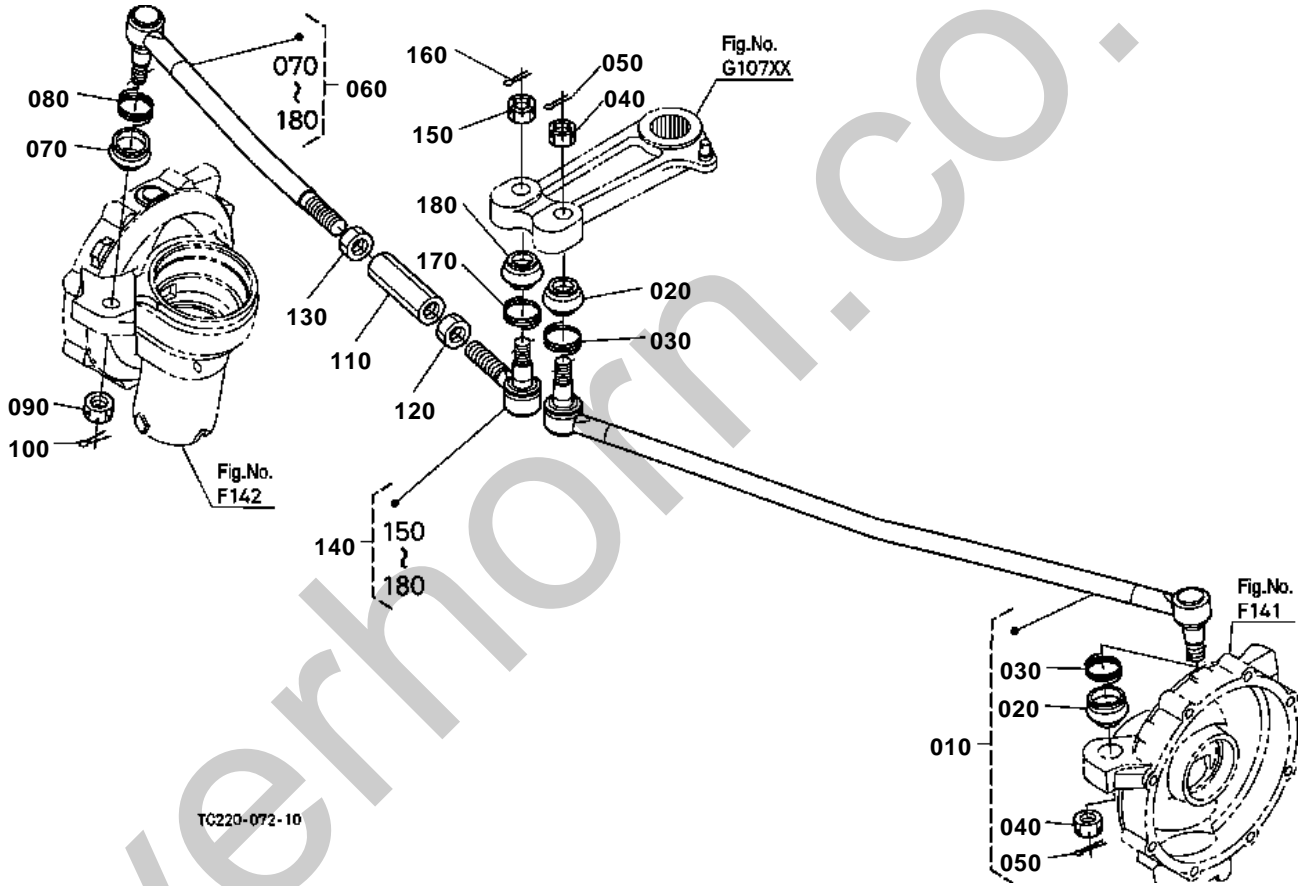

TC220-072-10



## STEERING LINKAGE (TIE ROD)

↔ Interchangeable; ≠ not interchangeable; ← new for old; → old for new

REF.No	Part No.	Description	Q'ty	S.No.	I/C	REMARKS	Weight (kgf)	Weight (lb)
010	TC220-13700	ASSY ROD TIE LH	1				1.97	4.334
020	32580-44780	COVER DUST	2				0.01	0.022
030	35270-12660	CLIP	2				0.005	0.011
040	36330-62750	NUT	2				0.022	0.0484
050	05511-50328	PIN SPLIT	2				0.002	0.0044
060	TC220-13740	ASSY ROD TIE RH	1				2.2	4.84
070	32580-44780	COVER DUST	1				0.01	0.022
080	35270-12660	CLIP	1				0.005	0.011
090	36330-62750	NUT	1				0.022	0.0484
100	05511-50328	PIN SPLIT	1				0.002	0.0044
110	32570-44720	ROD ADJUSTING	1				0.21	0.462
120	02172-50200	NUT	1				0.03	0.066
130	38630-44980	NUT	1				0.01	0.022
140	32580-44770	COMP.END TIE ROD RH	1				0.49	1.078
150	36330-62750	NUT	1				0.022	0.0484
160	05511-50328	PIN SPLIT	1				0.002	0.0044
170	35270-12660	CLIP	1				0.005	0.011
180	32580-44780	COVER DUST	1				0.01	0.022

HYDRAULIC PUMP

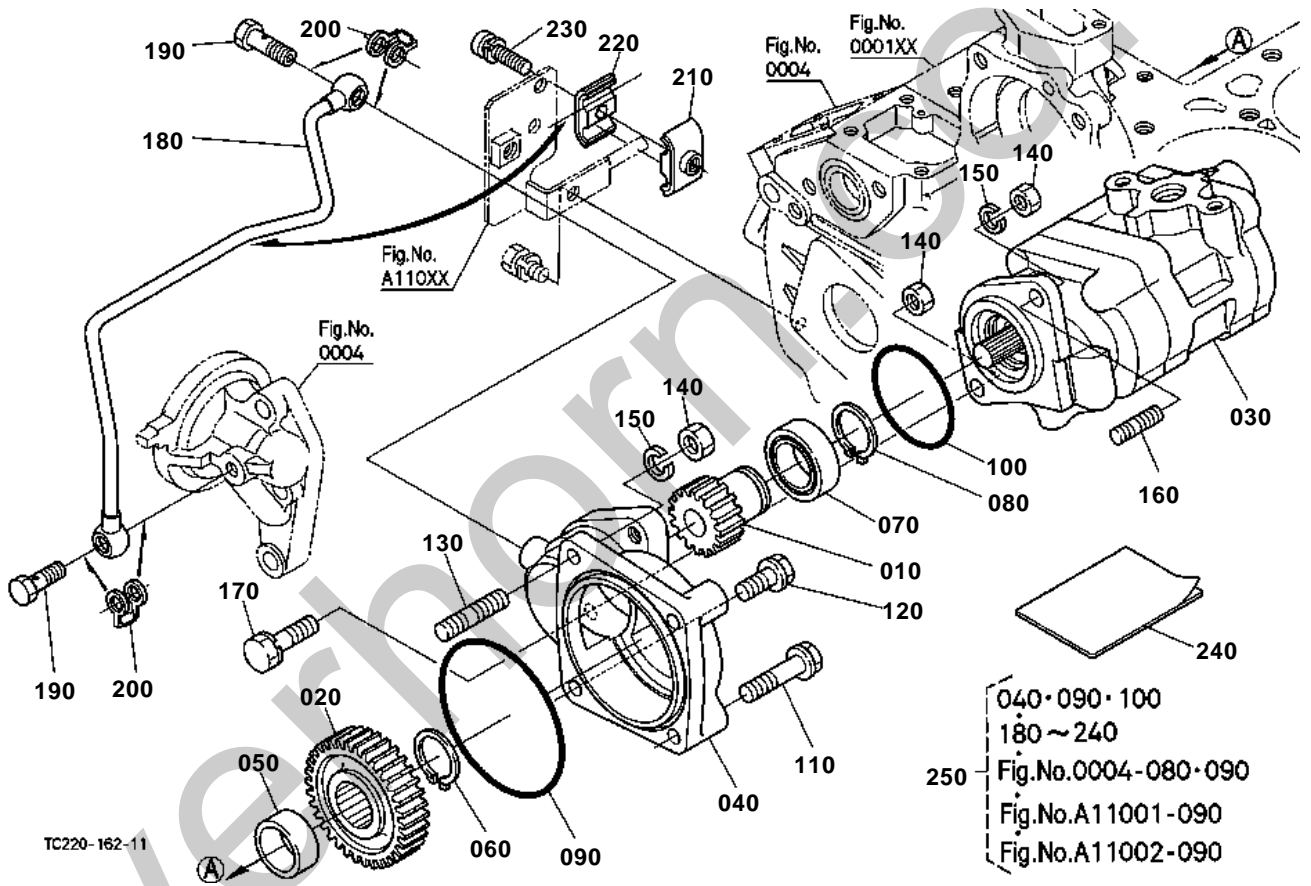



OLD PARTS

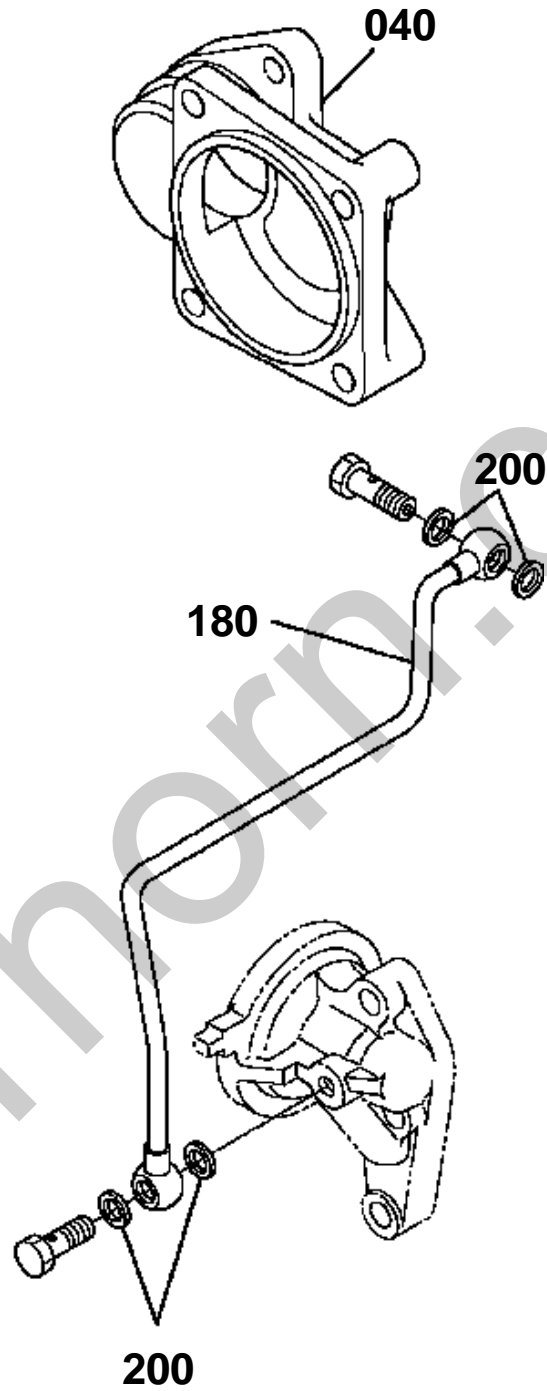

TC220-845-10

**HYDRAULIC PUMP**

↔ Interchangeable; ≠ not interchangeable; ← new for old; → old for new

REF.No	Part No.	Description	Q'ty	S.No.	I/C	REMARKS	Weight (kgf)	Weight (lb)
010	TC220-36820	GEAR PUMP DRIVE	1			18T	0.172	0.3784
020	TC220-36810	GEAR PUMP DRIVE	1			34T	0.41	0.902
030	T1150-36403	ASSY PUMP HYDRAULIC	1				2.75	6.05
040	34070-33612	HOLDER PUMP	1	<=52580			0.375	0.825
040	TD030-33610	HOLDER PUMP	1	>=52581	1		0	0
050	T1060-36830	COLLAR	1				0.031	0.0682
060	04612-00250	CIR CLIP EXTERNAL	1				0.002	0.0044
070	08241-05205	BEARING BALL	1				0.177	0.3894
080	04612-00250	CIR CLIP EXTERNAL	1				0.002	0.0044
090	04811-10850	O RING	1				0.002	0.0044
100	T1060-36620	O RING	1				0.001	0.0022
110	01754-50840	BOLT FLANGE	2				0.02	0.044
120	01754-50820	BOLT FLANGE	1				0.015	0.033
130	38240-36330	STUD	1				0.008	0.0176
140	02156-50080	NUT	3				0.004	0.0088
150	04512-60080	WASHER SPRING	2				0.002	0.0044
160	01513-60820	STUD	1				0.015	0.033
170	01123-50835	BOLT	1				0.02	0.044
180	TD030-16090	COMP.PIPE LUB.OIL	1	>=52581			0.12	0.264
180	TD030-16092	COMP.PIPE LUB.OIL	1	>=53277	-		0.12	0.264
190	32530-10710	BOLT JOINT	2	>=52581			0.015	0.033
200	15021-33660	GASKET	4	>=52581			0.001	0.0022
200	1G557-96650	GASKET	2		«		0.001	0.0022
210	15841-53850	CLAMP PIPE	1	>=52581			0.01	0.022
220	15841-53860	CLAMP PIPE	1	>=52581			0.009	0.0198
230	03024-50520	SCREW WITH WASHER	1	>=52581			0.004	0.0088
240	99999-99999	MANUAL INSTRUCTION	1	<=52580			0	0
250	TC220-99300	KIT HOLDER LUB.OIL	1	<=52580			0	0

HYDRAULIC PUMP [COMPONENT PARTS]

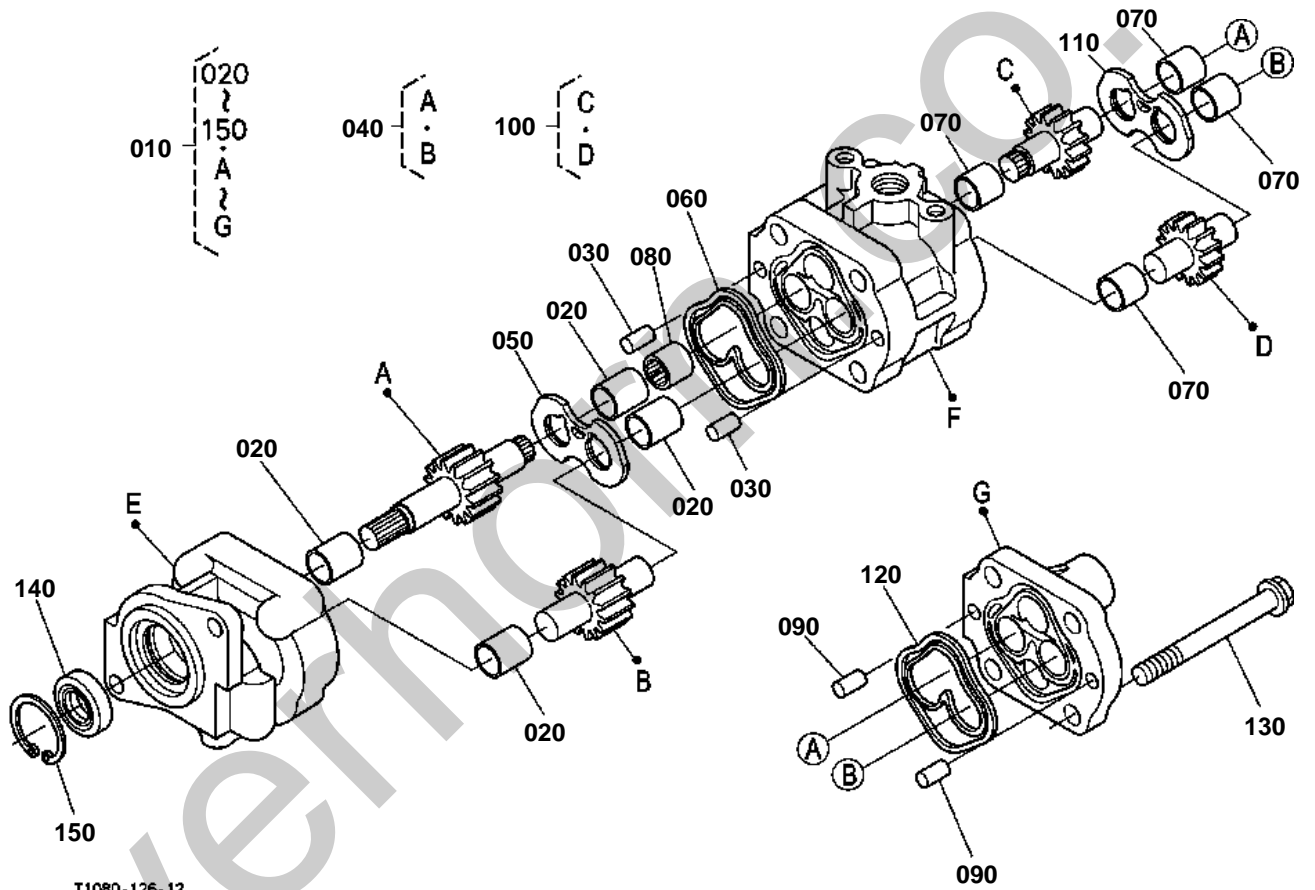

T1080-126-12



# HYDRAULIC PUMP [COMPONENT PARTS]

↔ Interchangeable; ≠ not interchangeable; ← new for old; → old for new

REF.No	Part No.	Description	Q'ty	S.No.	I/C	REMARKS	Weight (kgf)	Weight (lb)
010	T1150-36403	ASSY PUMP HYDRAULIC	1				2.75	6.05
020	K3511-36762	BUSH	4				0.01	0.022
030	05012-00814	PIN STRAIGHT	2				0.006	0.0132
040	T1060-36450	COMP.GEAR HYD.PUMP	1				0.33	0.726
050	6C140-36350	PLATE SIDE	1				0.05	0.11
060	6C040-36344	RING DOUBLE	1				0.003	0.0066
070	6A100-37232	BUSH	4				0.005	0.011
080	6A100-37430	COUPLING	1				0.01	0.022
090	05012-00814	PIN STRAIGHT	2				0.006	0.0132
100	T1060-36550	COMP.GEAR HYD.PUMP	1				0.2	0.44
110	6C140-36350	PLATE SIDE	1				0.05	0.11
120	6C040-36344	RING DOUBLE	1				0.003	0.0066
130	01754-51090	BOLT FLANGE	4				0.05	0.11
140	31381-76390	SEAL OIL	1				0.01	0.022
150	04611-00300	CIR CLIP INTERNAL	1				0.004	0.0088

HYDRAULIC OIL LINE(INLET) [EXCEPT HST TYPE]

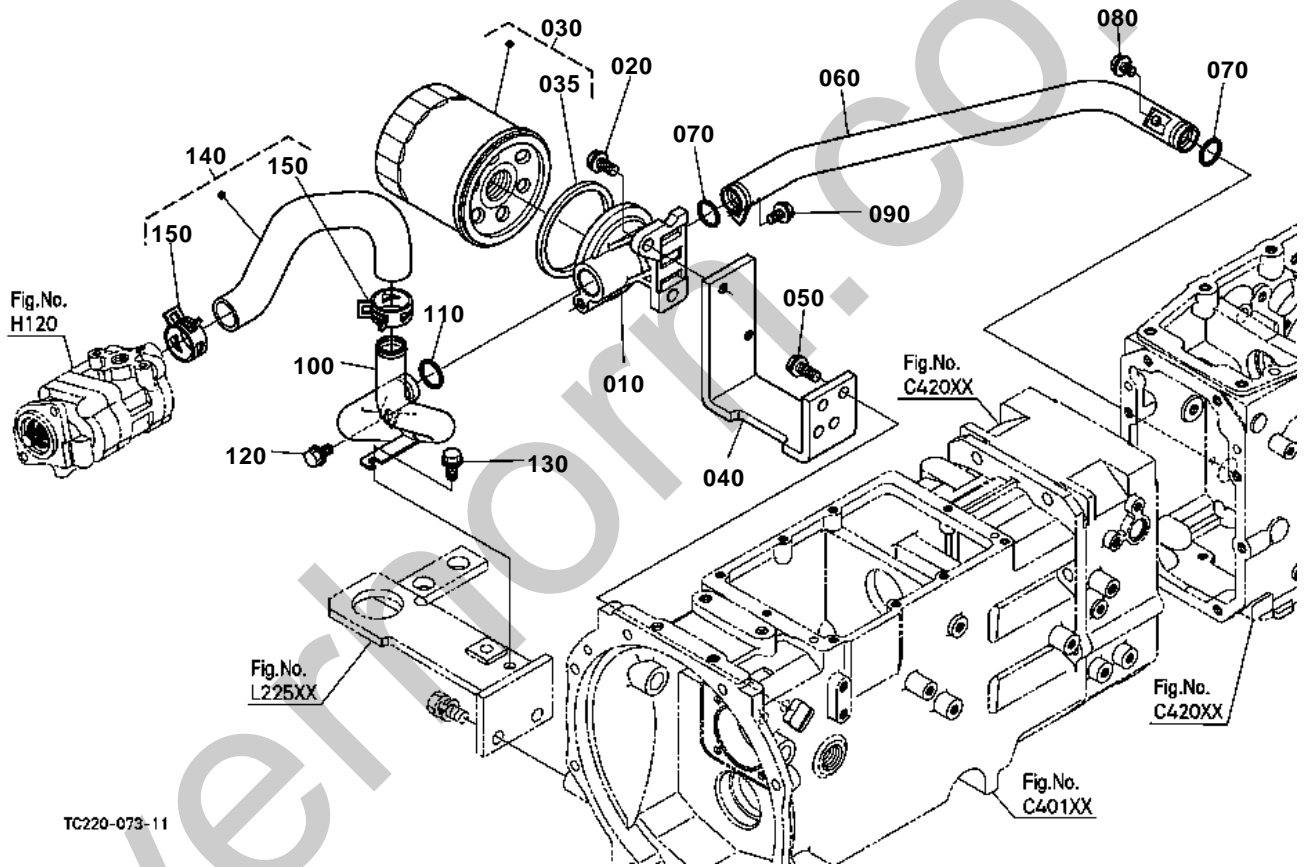

**HYDRAULIC OIL LINE(INLET) [EXCEPT HST TYPE]**

↔ Interchangeable; ≠ not interchangeable; ← new for old; → old for new

REF.No	Part No.	Description	Q'ty	S.No.	I/C	REMARKS	Weight (kgf)	Weight (lb)
010	TA040-33212	BRACKET FILTER	1				0.525	1.155
020	01774-61020	BOLT FLANGE	2				0.022	0.0484
030	3A431-82623	ASSY FILTER	1				0.48	1.056
035	T0070-37720	MAGNET OIL FILTER	1				0.04	0.088
040	TC220-33230	STAY FILTER BRACKET	1				1.46	3.212
050	01774-61020	BOLT FLANGE	2				0.022	0.0484
060	TC220-33310	PIPE INLET	1				0.44	0.968
070	04816-07230	O RING	2				0.002	0.0044
080	01754-50812	BOLT FLANGE	1				0.01	0.022
090	01754-50816	BOLT FLANGE	1				0.011	0.0242
100	TC220-33320	PIPE INLET	1	<=53276			0.37	0.814
100	TC220-33324	PIPE INLET	1	>=53277	┐		0.37	0.814
110	04816-07230	O RING	1				0.002	0.0044
120	01754-50816	BOLT FLANGE	1				0.011	0.0242
130	01754-50820	BOLT FLANGE	1	<=52262			0.015	0.033
130	01754-50816	BOLT FLANGE	1	>=52263	┐		0.011	0.0242
130	01754-50820	BOLT FLANGE	1	>=53277	┐		0.015	0.033
140	TC220-33330	ASSY HOSE INLET	1				0	0
150	31351-38180	BAND PIPE	2				0	0
150	16241-72970	BAND PIPE	2		«		0.015	0.033

HYDRAULIC OIL LINE(INLET) [HST TYPE]

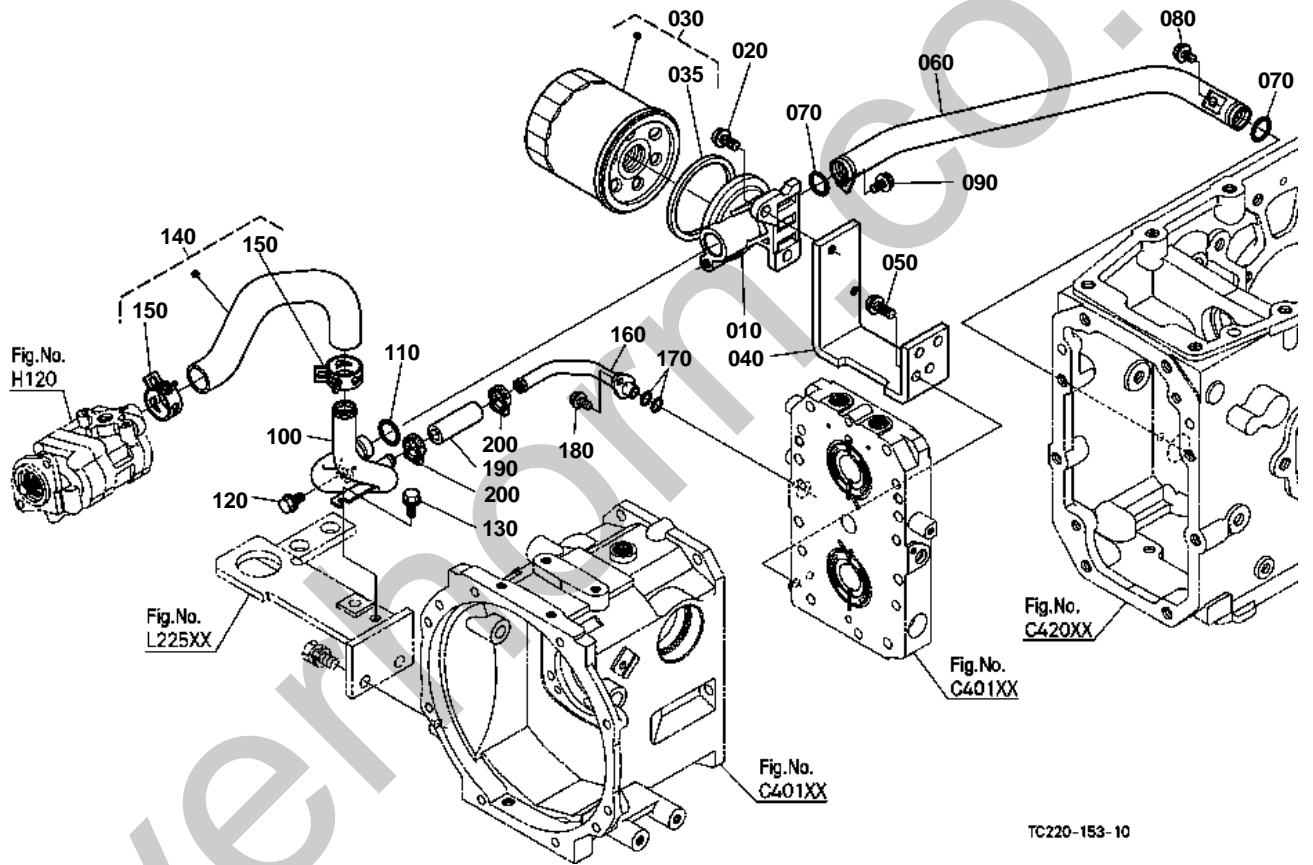

TC220-153-10



# HYDRAULIC OIL LINE(INLET) [HST TYPE]

↔ Interchangeable; ≠ not interchangeable; ← new for old; → old for new

REF.No	Part No.	Description	Q'ty	S.No.	I/C	REMARKS	Weight (kgf)	Weight (lb)
010	TA040-33212	BRACKET FILTER	1				0.525	1.155
020	01774-61020	BOLT FLANGE	2				0.022	0.0484
030	3A431-82623	ASSY FILTER	1				0.48	1.056
035	T0070-37720	MAGNET OIL FILTER	1				0.04	0.088
040	TC220-33230	STAY FILTER BRACKET	1				1.46	3.212
050	01774-61020	BOLT FLANGE	2				0.022	0.0484
060	TC220-33310	PIPE INLET	1				0.44	0.968
070	04816-07230	O RING	2				0.002	0.0044
080	01754-50812	BOLT FLANGE	1				0.01	0.022
090	01754-50816	BOLT FLANGE	1				0.011	0.0242
100	TC220-56320	PIPE INLET	1				0	0
110	04816-07230	O RING	1				0.002	0.0044
120	01754-50816	BOLT FLANGE	1				0.011	0.0242
130	01754-50816	BOLT FLANGE	1	<=53276			0.011	0.0242
130	01754-50820	BOLT FLANGE	1	>=53277	-		0.015	0.033
140	TC220-33330	ASSY HOSE INLET	1				0	0
150	16241-72970	BAND PIPE	2				0.015	0.033
160	TC220-56330	PIPE SUCTION HST	1				0	0
170	04816-00150	O RING	2				0.003	0.0066
180	01754-50814	BOLT FLANGE	1				0.005	0.011
190	TC220-56340	HOSE SUCTION HST	1				0	0
200	66204-36280	BAND PIPE	2				0.02	0.044



HYDRAULIC OIL LINE(DELIVERY)

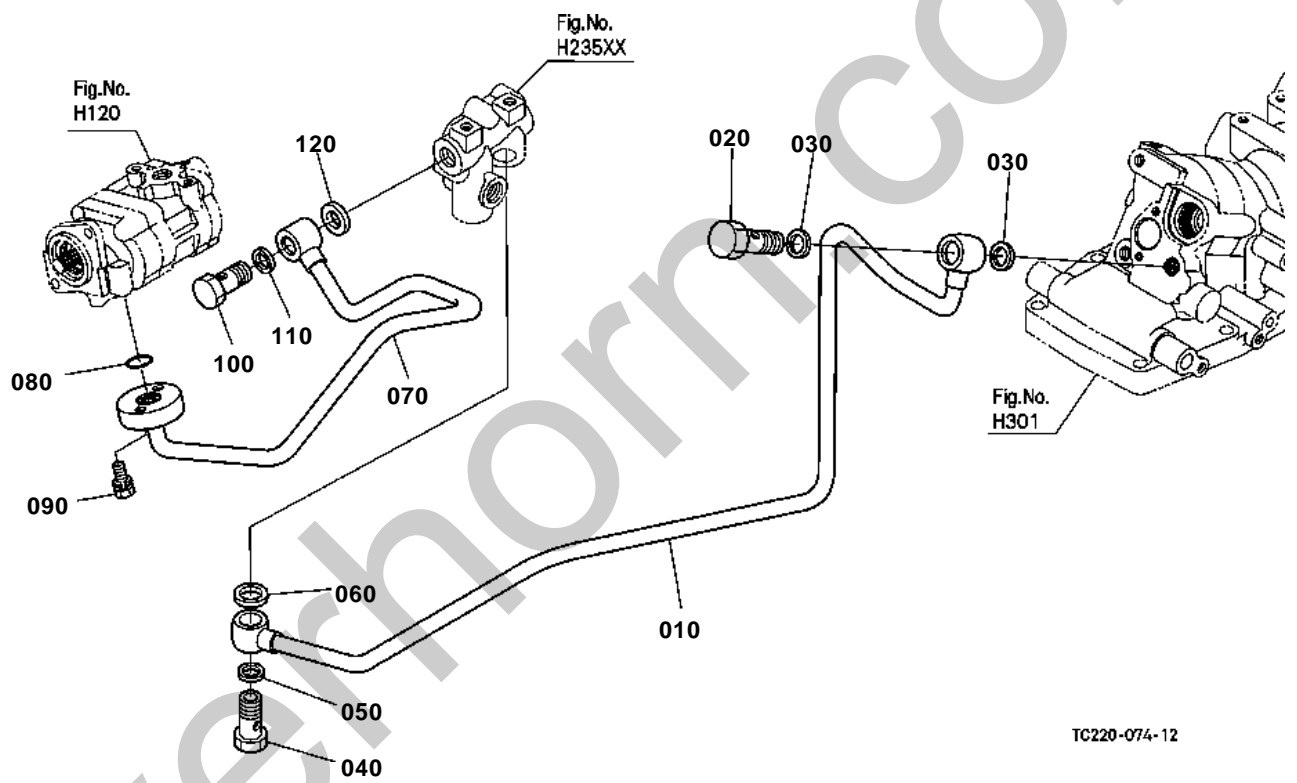

TC220-074-12

## OLD PARTS

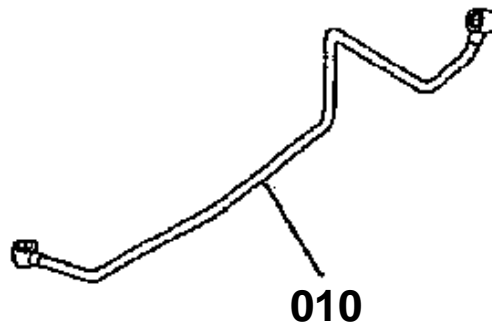

Silverhorn.CO.UK

TC220-821-10



# HYDRAULIC OIL LINE(DELIVERY)

↔ Interchangeable; ≠ not interchangeable; ← new for old; → old for new

REF.No	Part No.	Description	Q'ty	S.No.	I/C	REMARKS	Weight (kgf)	Weight (lb)
010	TC220-33410	COMP.PIPE DELIVERY	1	<=52262			0.8	1.76
010	TC220-33412	COMP.PIPE DELIVERY	1	>=52263	-		0.8	1.76
020	66591-36250	JOINT	1				0.08	0.176
030	67111-37180	GASKET	2				0.003	0.0066
040	66591-36250	JOINT	1				0.08	0.176
050	67111-37180	GASKET	1				0.003	0.0066
060	67401-36720	GASKET	1				0.005	0.011
070	TC220-33420	COMP.PIPE DELIVERY	1				0	0
080	04817-00200	O RING	1				0.011	0.0242
090	01123-50830	BOLT	2				0.015	0.033
100	66591-36250	JOINT	1				0.08	0.176
110	67111-37180	GASKET	1				0.003	0.0066
120	67401-36720	GASKET	1				0.005	0.011

HYDRAULIC OIL LINE(POWER STEERING) [EXCEPT HST TYPE]

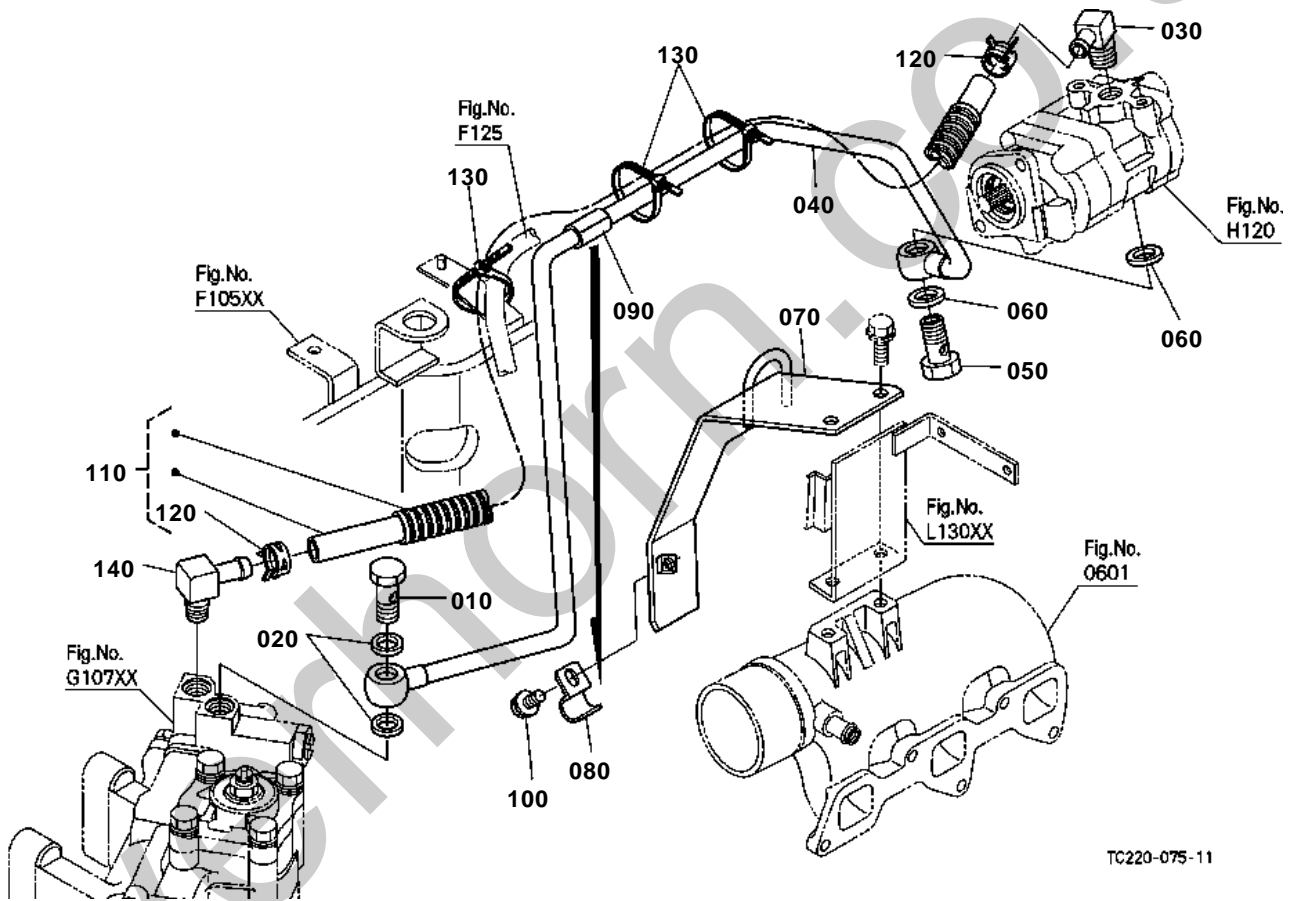

TC220-075-11

## OLD PARTS

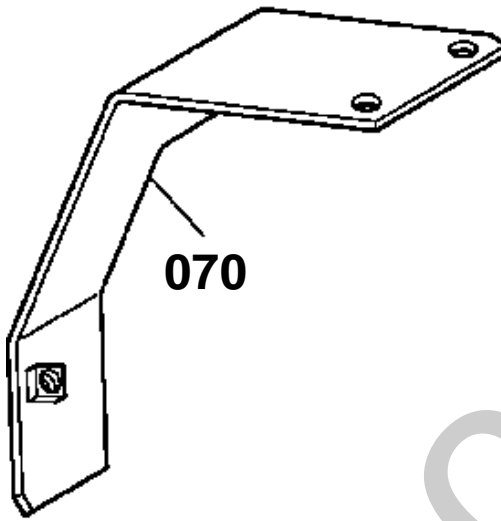

TC220-835-10



# HYDRAULIC OIL LINE(POWER STEERING) [EXCEPT HST TYPE]

↔ Interchangeable; ≠ not interchangeable; ← new for old; → old for new

REF.No	Part No.	Description	Q'ty	S.No.	I/C	REMARKS	Weight (kgf)	Weight (lb)
010	TC220-33550	BOLT JOINT	1				0.049	0.1078
020	T1060-33560	GASKET	2				0.003	0.0066
030	T1270-36910	JOINT	1				0.072	0.1584
040	TC220-33510	PIPE DELIVERY	1				0.75	1.65
050	66591-36250	JOINT	1				0.08	0.176
060	67111-37180	GASKET	2				0.003	0.0066
070	TC220-33580	STAY PIPE	1	<=52427			0.48	1.056
070	TC220-33582	STAY PIPE	1	>=52428	-		0.48	1.056
080	TC220-33570	CLAMP PIPE	1				0.023	0.0506
090	TC220-33590	TUBE PS PIPE	1				0.006	0.0132
100	01754-50816	BOLT FLANGE	1				0.011	0.0242
110	TC220-33530	ASSY HOSE RETURN	1				0.24	0.528
120	T1060-33630	BAND PIPE	2				0.006	0.0132
130	53581-64150	BAND CORD	3				0.002	0.0044
140	T1270-36910	JOINT	1				0.072	0.1584

HYDRAULIC OIL LINE(POWER STEERING) [HST TYPE]

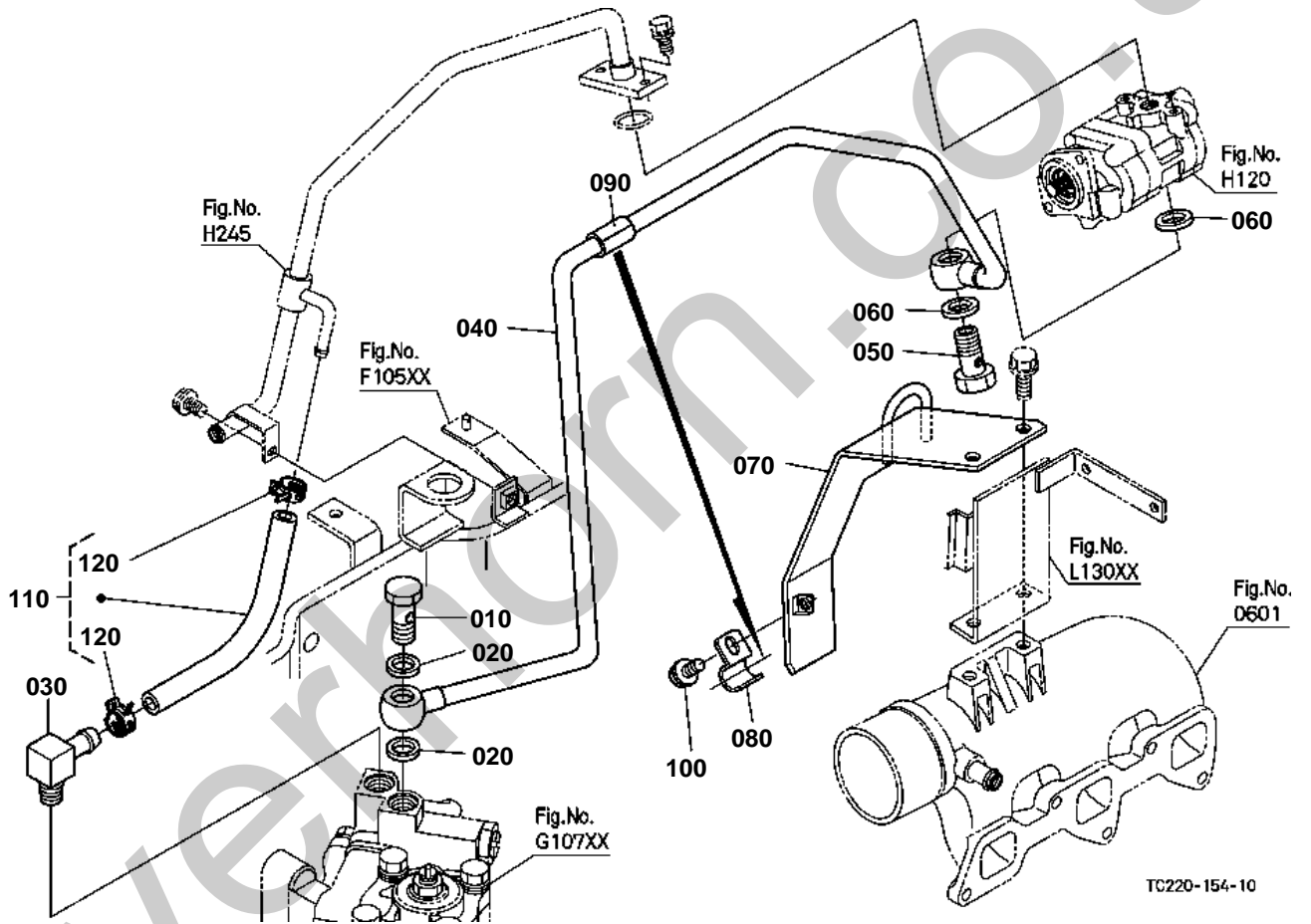



# HYDRAULIC OIL LINE(POWER STEERING) [HST TYPE]

↔ Interchangeable; ≠ not interchangeable; ← new for old; → old for new

REF.No	Part No.	Description	Q'ty	S.No.	I/C	REMARKS	Weight (kgf)	Weight (lb)
010	TC220-33550	BOLT JOINT	1				0.049	0.1078
020	T1060-33560	GASKET	2				0.003	0.0066
030	T1270-36910	JOINT	1				0.072	0.1584
040	TC220-33510	PIPE DELIVERY	1				0.75	1.65
050	66591-36250	JOINT	1				0.08	0.176
060	67111-37180	GASKET	2				0.003	0.0066
070	TC220-33582	STAY PIPE	1				0.48	1.056
080	TC220-33570	CLAMP PIPE	1				0.023	0.0506
090	TC220-33590	TUBE PS PIPE	1				0.006	0.0132
100	01754-50816	BOLT FLANGE	1				0.011	0.0242
110	TC220-56180	ASSY HOSE RETURN	1				0	0
120	T1060-33630	BAND PIPE	2				0.006	0.0132



HYDRAULIC OUTLET BLOCK [EXCEPT HST TYPE]

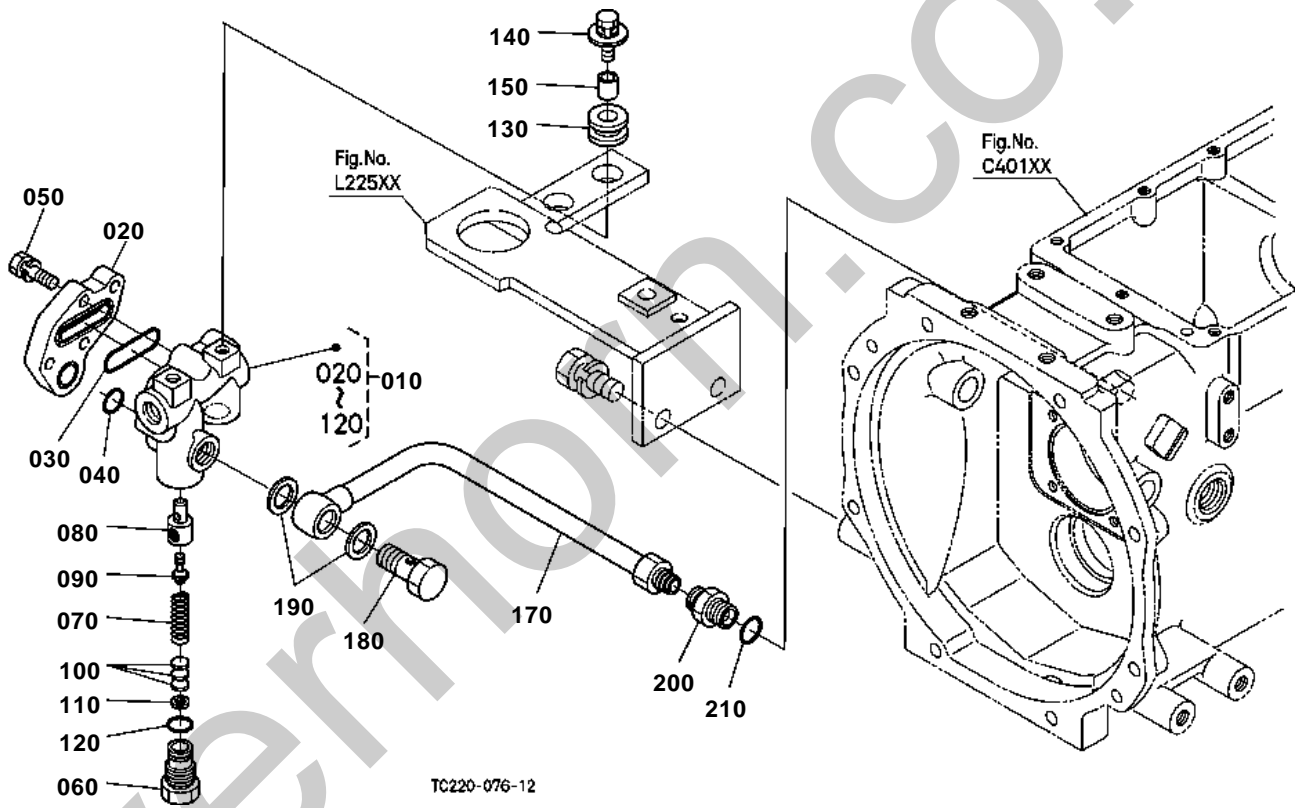

# OLD PARTS

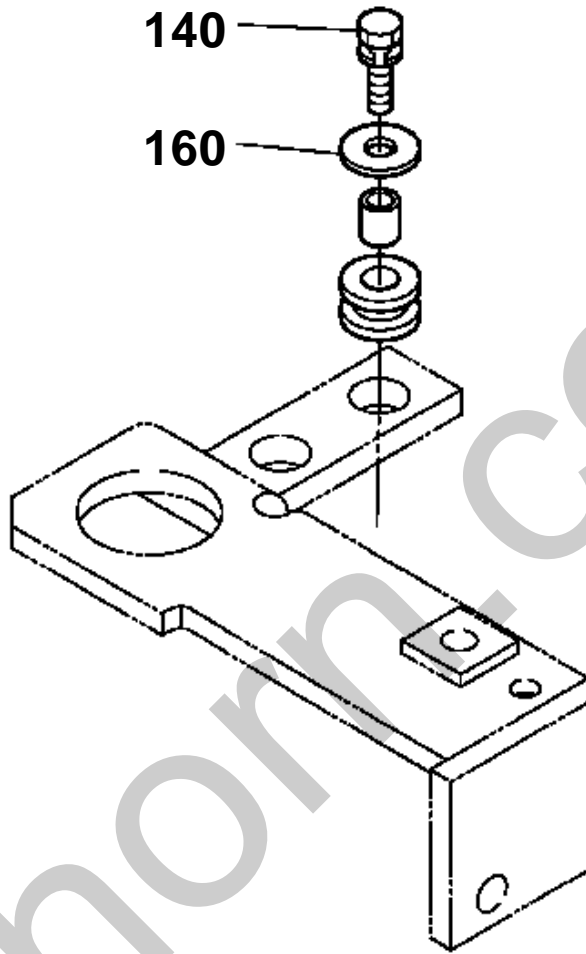

TC220-844-10



# HYDRAULIC OUTLET BLOCK [EXCEPT HST TYPE]

↔ Interchangeable; ≠ not interchangeable; ← new for old; → old for new

REF.No	Part No.	Description	Q'ty	S.No.	I/C	REMARKS	Weight (kgf)	Weight (lb)
010	TC220-37500	ASSY BLOCK FRONT HYD	1				1.3	2.86
020	TD060-37610	CAP HYD.BLOCK	1				0.14	0.308
030	04817-06400	O RING	1				0.003	0.0066
040	04817-05170	O RING	1				0.002	0.0044
050	01123-50828	BOLT	4				0.014	0.0308
060	31351-37910	PLUG	1				0.06	0.132
070	31351-37920	SPRING RELIEF	1				0.02	0.044
080	31351-37930	SEAT RELIEF VALVE	1				0.02	0.044
090	31351-37940	POPPET	1				0.005	0.011
100	31351-37950	SHIM	5			0.4mm	0.001	0.0022
100	31351-37960	SHIM	2			0.2mm	0.001	0.0022
100	31351-37970	SHIM	2			0.1mm	0.001	0.0022
110	04013-60050	WASHER PLAIN	2				0.001	0.0022
120	04811-10160	O RING	1				0.001	0.0022
130	TA040-37590	CUSHION	2				0.006	0.0132
140	01123-50830	BOLT	2	<=52262			0.015	0.033
140	01127-50830	BOLT	2	>=52263			0.023	0.0506
150	35999-02550	COLLAR	2				0.01	0.022
160	04015-60080	WASHER PLAIN	2	<=52262			0.01	0.022
170	TC220-37550	COMP.PIPE RETURN	1				0.28	0.616
180	66591-36250	JOINT	1				0.08	0.176
190	67111-37180	GASKET	2				0.003	0.0066
200	06012-51533	JOINT PIPE	1				0.066	0.1452
210	04817-00140	O RING	1				0.001	0.0022

HYDRAULIC OUTLET BLOCK [HST TYPE]

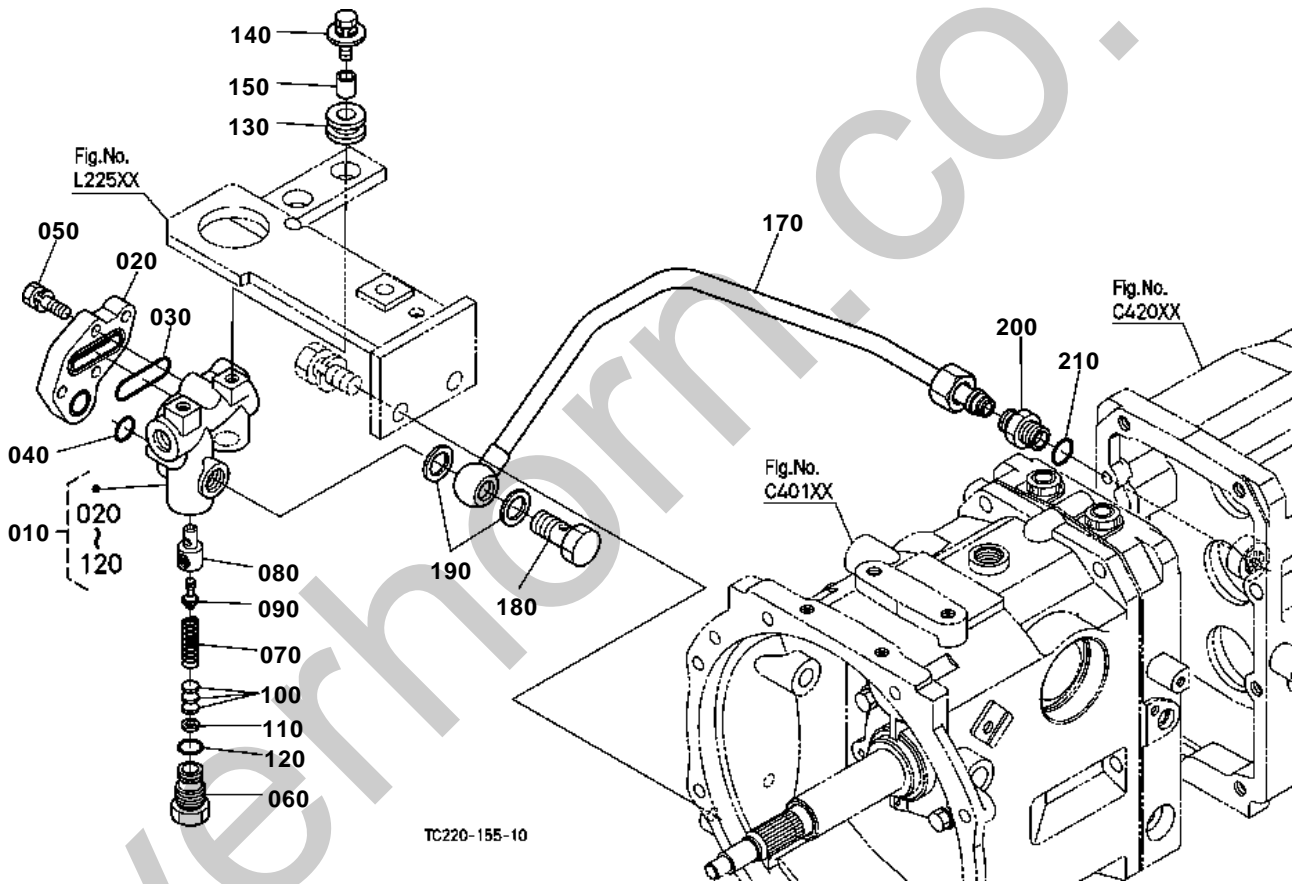



# HYDRAULIC OUTLET BLOCK [HST TYPE]

↔ Interchangeable; ≠ not interchangeable; ← new for old; → old for new

REF.No	Part No.	Description	Q'ty	S.No.	I/C	REMARKS	Weight (kgf)	Weight (lb)
010	TC220-37500	ASSY BLOCK FRONT HYD	1				1.3	2.86
020	TD060-37610	CAP HYD.BLOCK	1				0.14	0.308
030	04817-06400	O RING	1				0.003	0.0066
040	04817-05170	O RING	1				0.002	0.0044
050	01123-50828	BOLT	4				0.014	0.0308
060	31351-37910	PLUG	1				0.06	0.132
070	31351-37920	SPRING RELIEF	1				0.02	0.044
080	31351-37930	SEAT RELIEF VALVE	1				0.02	0.044
090	31351-37940	POPPET	1				0.005	0.011
100	31351-37950	SHIM	5			0.4mm	0.001	0.0022
100	31351-37960	SHIM	2			0.2mm	0.001	0.0022
100	31351-37970	SHIM	2			0.1mm	0.001	0.0022
110	04013-60050	WASHER PLAIN	2				0.001	0.0022
120	04811-10160	O RING	1				0.001	0.0022
130	TA040-37590	CUSHION	2				0.006	0.0132
140	01127-50830	BOLT	2				0.023	0.0506
150	35999-02550	COLLAR	2				0.01	0.022
160	99999-99999	BLANK	0				0	0
170	TC220-56460	COMP.PIPE RETURN	1				0	0
180	66591-36250	JOINT	1				0.08	0.176
190	67111-37180	GASKET	2				0.003	0.0066
200	06012-51533	JOINT PIPE	1				0.066	0.1452
210	04817-00140	O RING	1				0.001	0.0022

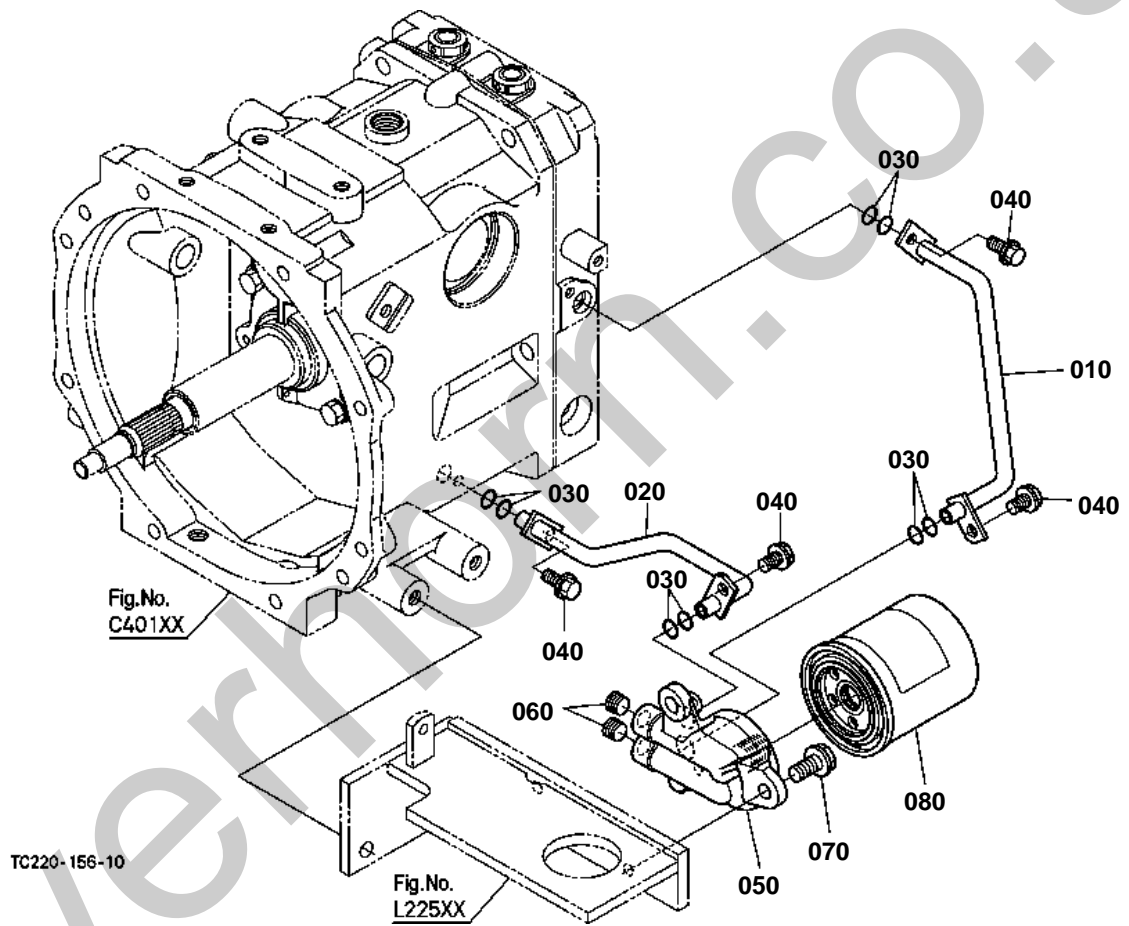



# HYDRAULIC PIPE(HST) [HST TYPE]

↔ Interchangeable; ≠ not interchangeable; ← new for old; → old for new

REF.No	Part No.	Description	Q'ty	S.No.	I/C	REMARKS	Weight (kgf)	Weight (lb)
010	TC220-56210	PIPE HST FILTER	1				0	0
020	TC220-56220	PIPE HST FILTER	1				0	0
030	04816-00120	O RING	8				0.001	0.0022
040	01754-50814	BOLT FLANGE	4				0.005	0.011
050	T0470-33210	BRACKET FILTER	1				0.255	0.561
060	38010-67020	PLUG	2				0.007	0.0154
070	01774-61020	BOLT FLANGE	2				0.022	0.0484
080	K7561-14070	FILTER OIL	1				0.4	0.88

OIL COOLER [HST TYPE]

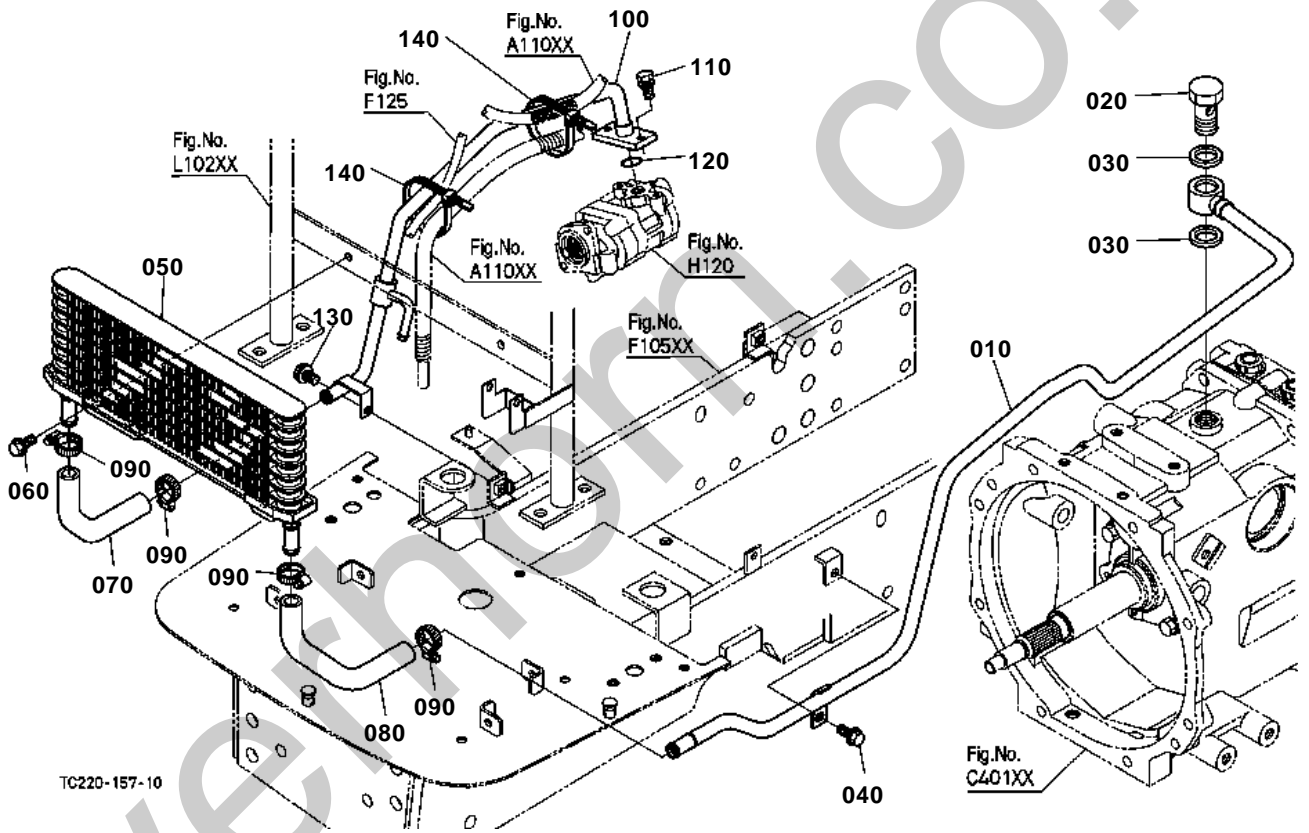





# OIL COOLER [HST TYPE]

↔ Interchangeable; ≠ not interchangeable; ← new for old; → old for new

REF.No	Part No.	Description	Q'ty	S.No.	I/C	REMARKS	Weight (kgf)	Weight (lb)
010	TC220-56133	PIPE HST RETURN	1				0	0
020	TD060-56210	BOLT JOINT	1				0	0
030	04714-00400	GASKET	2				0.003	0.0066
040	01754-50812	BOLT FLANGE	1				0.01	0.022
050	TA240-55370	COOLER OIL	1				0.72	1.584
060	01754-50816	BOLT FLANGE	2				0.011	0.0242
070	TC220-56172	HOSE O/C OUTLET	1				0	0
080	TC220-56152	HOSE O/C INLET	1				0	0
090	66204-36280	BAND PIPE	4				0.02	0.044
100	TC220-56142	PIPE O/C RETURN	1				0	0
110	01123-50820	BOLT	2				0.011	0.0242
120	04817-00220	O RING	1				0.001	0.0022
130	01754-50816	BOLT FLANGE	1				0.011	0.0242
140	53581-64150	BAND CORD	2				0.002	0.0044

HYDRAULIC CYLINDER

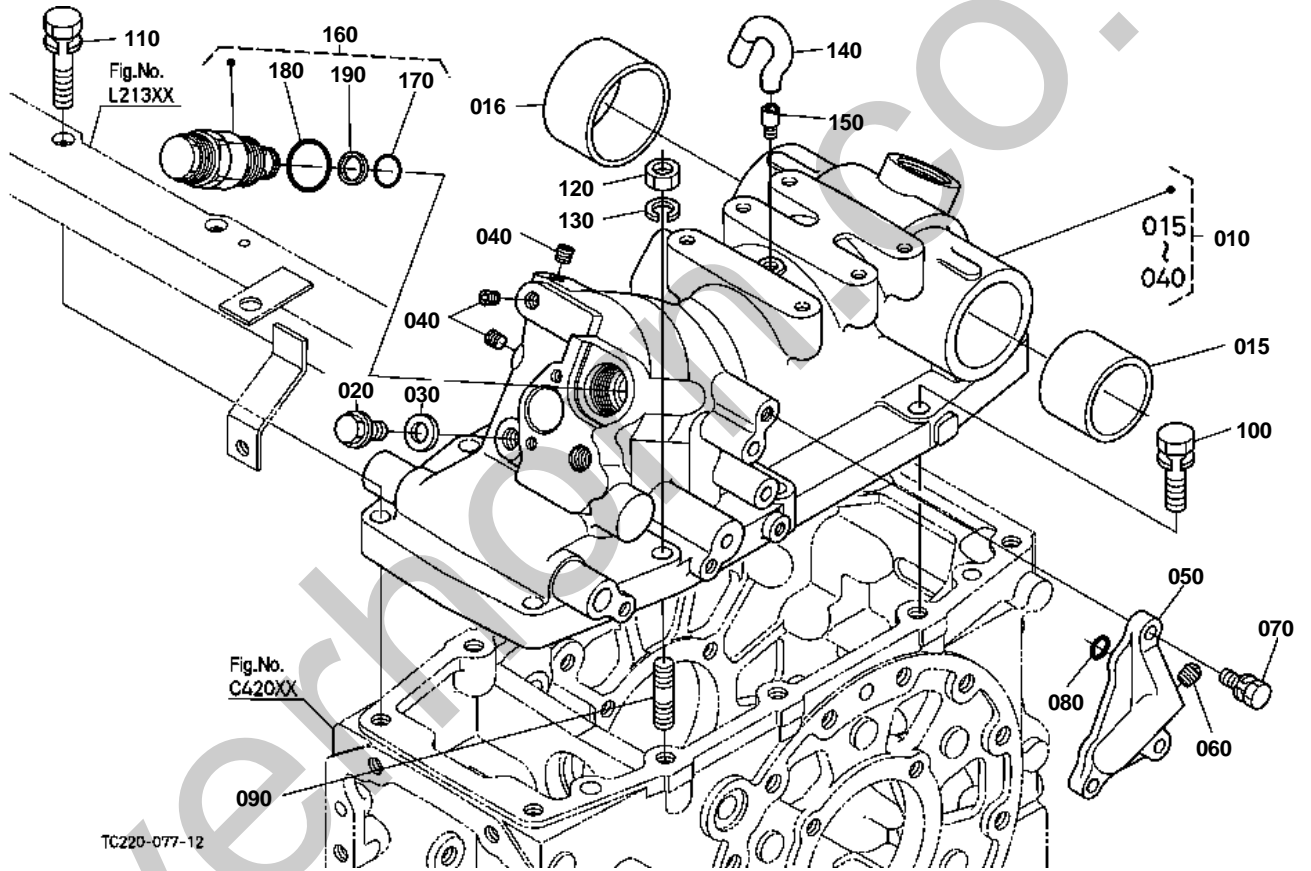

OLD PARTS

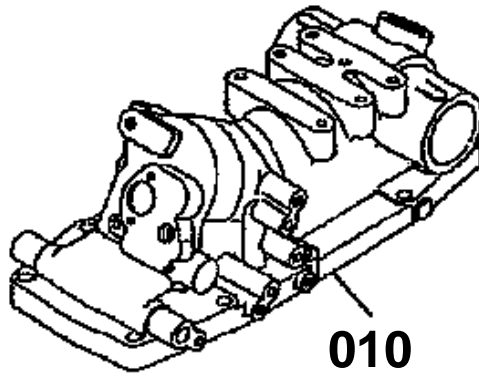

010

Silverhorn.CO.UK

TC220-807-10



# HYDRAULIC CYLINDER

↔ Interchangeable; ≠ not interchangeable; ← new for old; → old for new

REF.No	Part No.	Description	Q'ty	S.No.	I/C	REMARKS	Weight (kgf)	Weight (lb)
010	TC220-34110	CASE HYD.CYLINDER	1	<=50333		NOT SALE	0	0
010	TC220-99010	ASSY CASE CYLINDER	1	>=50334	-		0	0
015	34150-37460	BUSH	1				0.062	0.1364
016	31321-37450	BUSH	1				0.09	0.198
020	37150-36730	PLUG	1				0.03	0.066
030	37150-36720	GASKET	1				0.01	0.022
040	31351-37160	PLUG	3				0.003	0.0066
050	31351-37282	COVER CYL.LH	1				0.12	0.264
060	06312-10010	PLUG	1				0.007	0.0154
070	01123-50825	BOLT	3				0.013	0.0286
080	04817-00100	O RING	3				0.001	0.0022
090	01574-51245	STUD	2				0.051	0.1122
100	01133-51245	BOLT	6				0.055	0.121
110	01133-51255	BOLT	2				0.06	0.132
120	02176-50120	NUT	2				0.01	0.022
130	04512-60120	WASHER SPRING	2				0.005	0.011
140	31351-37140	BREATHER	1				0.01	0.022
150	36200-21610	BREATHER	1				0.008	0.0176
160	YW125-00102	ASSY VALVE SAFETY	1	>=50334			0.4	0.88
170	04817-00160	O RING	1	>=50334			0.001	0.0022
180	04816-06280	O RING	2	>=50334			0.002	0.0044
190	YT133-00160	RING BACK UP	1	>=50334			0.001	0.0022

CYLINDER FRONT COVER

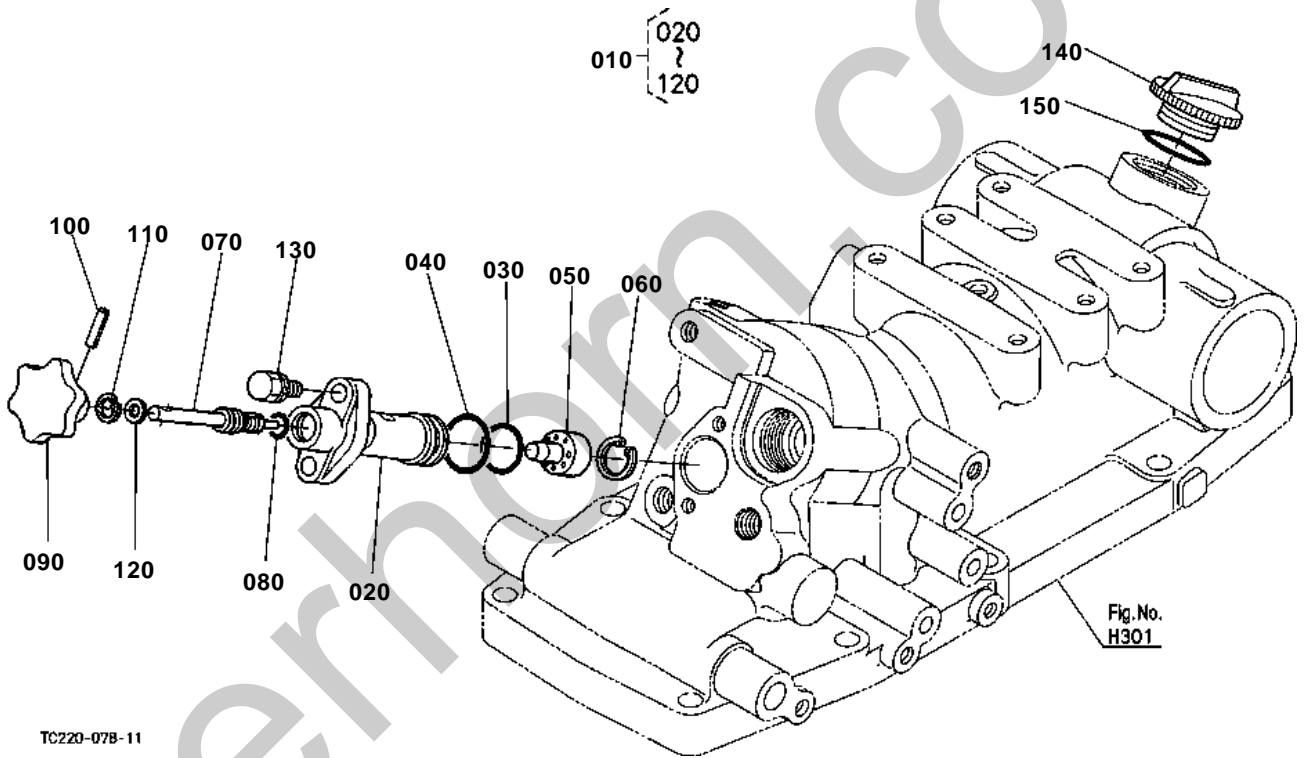

TC220-078-11



## CYLINDER FRONT COVER

↔ Interchangeable; ≠ not interchangeable; ← new for old; → old for new

REF.No	Part No.	Description	Q'ty	S.No.	I/C	REMARKS	Weight (kgf)	Weight (lb)
010	31351-37200	ASSY COVER CYL.FRONT	1				0.3	0.66
020	31351-37210	COVER CYL.FRONT	1				0.315	0.693
030	04817-00220	O RING	1				0.001	0.0022
040	04817-06250	O RING	1				0.001	0.0022
050	38240-37250	COLLAR ADJUSTING	1				0.01	0.022
060	04611-00160	CIR CLIP INTERNAL	1				0.001	0.0022
070	31351-37220	SHAFT HYD.ADJUST.	1				0.04	0.088
080	04817-00100	O RING	1				0.001	0.0022
090	34150-37230	GRIP	1				0.04	0.088
100	05411-00418	PIN SPRING	1				0.001	0.0022
110	34150-37260	CIR CLIP INTERNAL	1				0.001	0.0022
120	04012-50080	WASHER PLAIN	1				0.001	0.0022
130	01123-50825	BOLT	2				0.013	0.0286
140	38240-21410	PLUG	1				0.015	0.033
150	04817-50300	O RING	1				0.001	0.0022

LIFT ARM

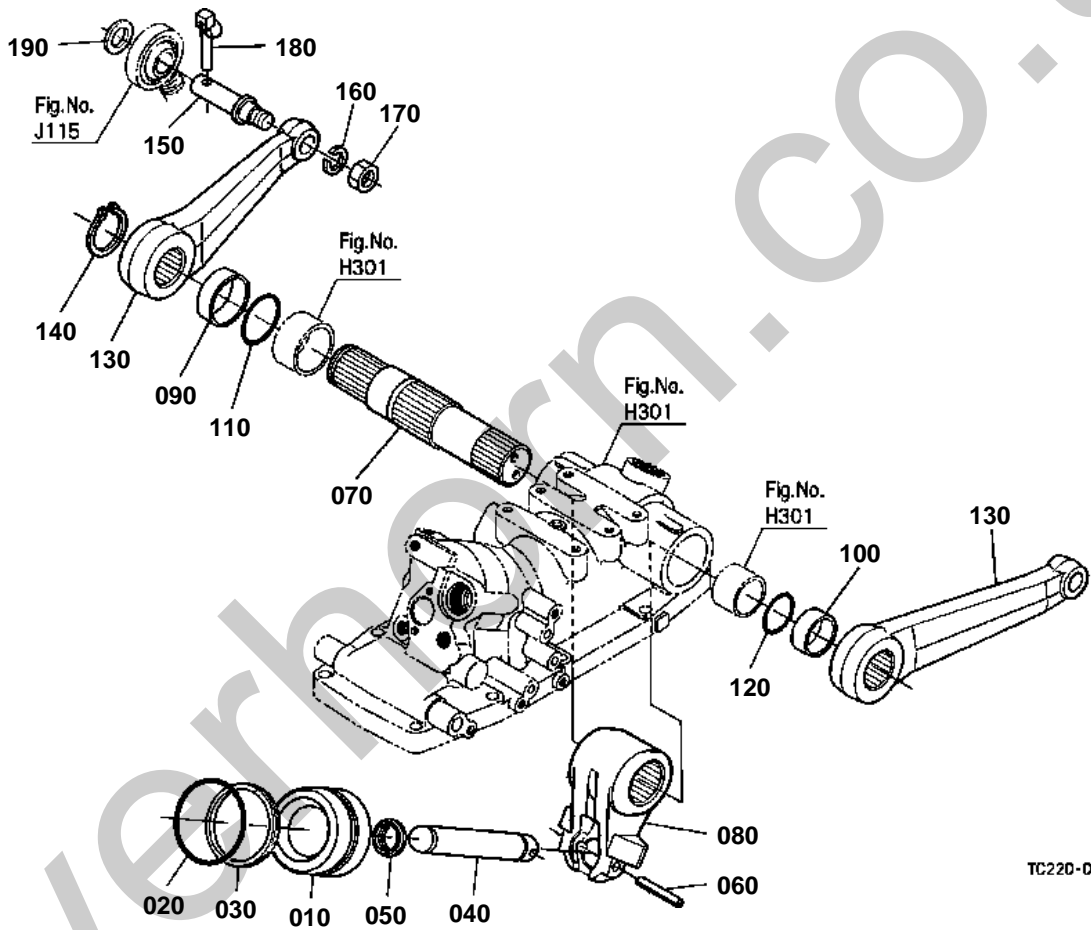

TC220-079-10

**LIFT ARM**

↔ Interchangeable; ≠ not interchangeable; ← new for old; → old for new

REF.No	Part No.	Description	Q'ty	S.No.	I/C	REMARKS	Weight (kgf)	Weight (lb)
010	31321-37310	PISTON HYD.	1				1.08	2.376
020	04811-00650	O RING	1				0.007	0.0154
030	34220-37380	RING BACK UP	1				0.001	0.0022
040	31351-37320	ROD HYD.	1				0.605	1.331
050	31351-37330	GUIDE HYD.ROD	1				0.003	0.0066
060	05411-00656	PIN SPRING	1				0.006	0.0132
070	31321-37430	SHAFT HYD.ARM	1				2.22	4.884
080	31321-37445	ARM HYDRAULIC	1				1.55	3.41
090	34150-37480	COLLAR	1				0.005	0.011
100	34150-37490	COLLAR	1				0.002	0.0044
110	04817-50450	O RING	1				0.003	0.0066
120	04817-06400	O RING	1				0.003	0.0066
130	TA040-34610	ARM LIFT	2				2.22	4.884
140	04612-00400	CIR CLIP EXTERNAL	1				0.005	0.011
150	30442-37690	PIN LIFT ROD	2				0.2	0.44
160	04512-60160	WASHER SPRING	2				0.01	0.022
170	02174-50160	NUT	2				0.022	0.0484
180	34150-37640	PIN SET	2				0.06	0.132
190	04011-50180	WASHER PLAIN	2				0.012	0.0264



FEED BACK LEVER

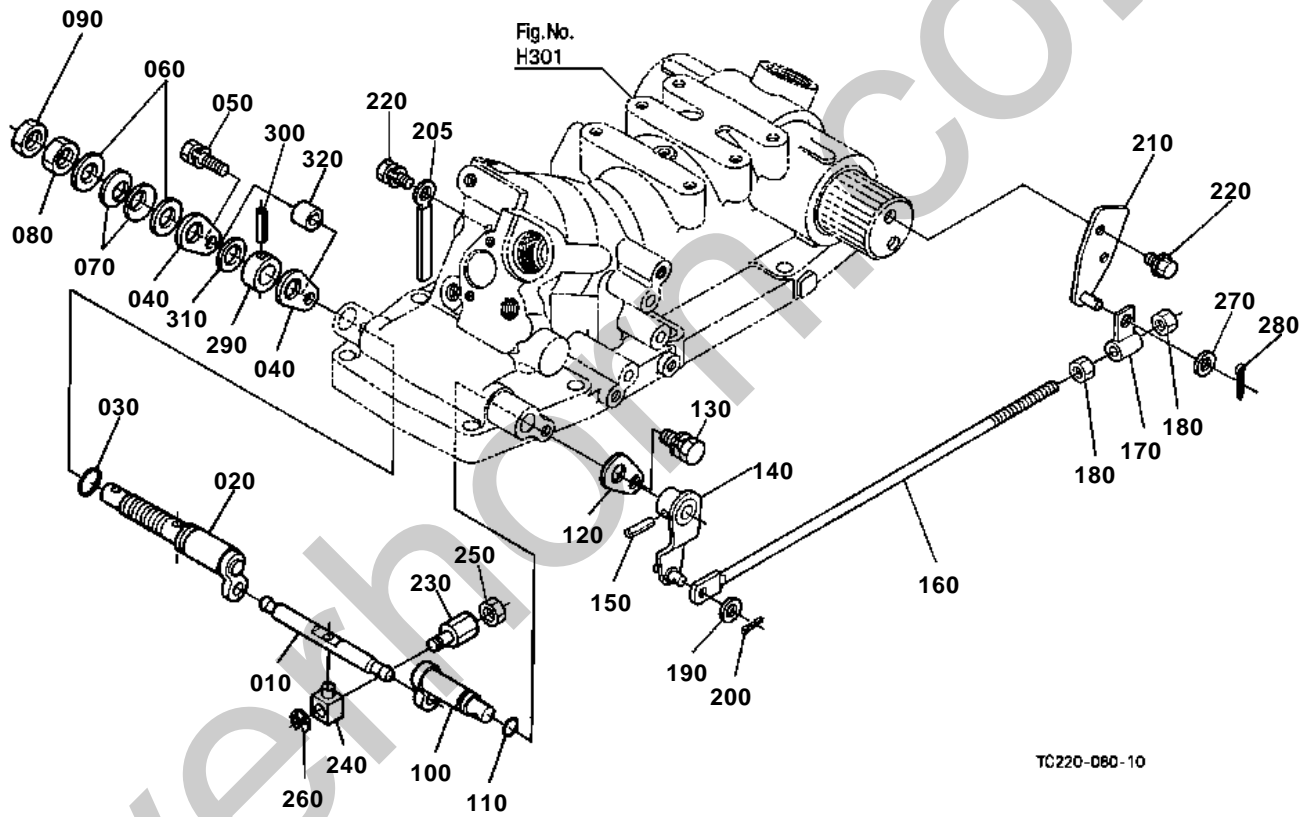



## FEED BACK LEVER

↔ Interchangeable; ≠ not interchangeable; ← new for old; → old for new

REF.No	Part No.	Description	Q'ty	S.No.	I/C	REMARKS	Weight (kgf)	Weight (lb)
010	31351-37640	LEVER SPOOL DRIVE	1				0.05	0.11
020	TA140-37650	ARM CONTROL	1				0.162	0.3564
030	04817-00140	O RING	1				0.001	0.0022
040	31351-37660	SET PLATE	2				0.01	0.022
050	01123-50830	BOLT	1				0.015	0.033
060	04013-60140	WASHER PLAIN	2				0.01	0.022
070	34260-36880	SPRING PLATE	2				0.006	0.0132
080	02174-50140	NUT	1				0.014	0.0308
090	02172-50140	NUT	1				0.01	0.022
100	31351-37750	SHAFT BACK LEVER	1				0.1	0.22
110	04816-00120	O RING	1				0.001	0.0022
120	38240-36890	SET PLATE	1				0.013	0.0286
130	01123-60816	BOLT	1				0.01	0.022
140	31351-37760	LEVER FEED BACK	1				0.08	0.176
150	05411-00525	PIN SPRING	1				0.002	0.0044
160	31321-37770	ROD FEED BACK	1				0.12	0.264
170	31351-37780	ROD CONTROL	1				0.03	0.066
180	02114-50080	NUT	2				0.005	0.011
190	04013-60080	WASHER PLAIN	1				0.002	0.0044
200	05511-50218	PIN SPLIT	1				0.001	0.0022
205	13824-67580	CLAMP CORD	1				0.006	0.0132
210	T0070-36010	LINK CONTROL	1				0.07	0.154
220	01754-50812	BOLT FLANGE	3				0.01	0.022
230	67531-38280	JOINT SPOOL	1				0.17	0.374
240	37150-36420	JOINT SPOOL	1				0.02	0.044
250	02112-50080	NUT	1				0.003	0.0066
260	04613-50060	CIR CLIP EXTERNAL	1				0.001	0.0022
270	04013-60080	WASHER PLAIN	1				0.002	0.0044
280	05511-50215	PIN SPLIT	1				0.001	0.0022
290	TA140-36900	SPACER	1				0.031	0.0682
300	05411-00528	PIN SPRING	1				0.003	0.0066
310	TA140-36920	PLATE FRICTION	1				0.002	0.0044
320	TA140-36930	SPACER	1				0.014	0.0308

CONTROL VALVE [OLD TYPE]

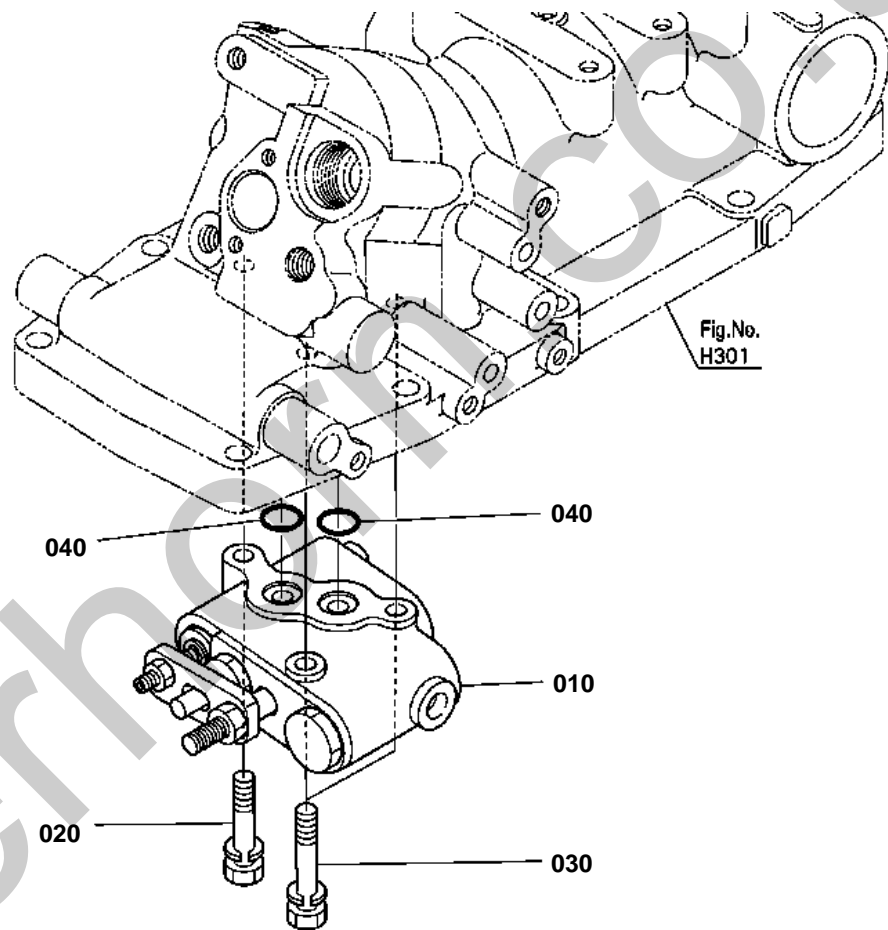

TC220-081-10



**CONTROL VALVE [OLD TYPE]**  
S.No.;<=57744

↔ Interchangeable; ≠ not interchangeable; ← new for old; → old for new

REF.No	Part No.	Description	Q'ty	S.No.	I/C	REMARKS	Weight (kgf)	Weight (lb)
010	31391-39002	ASSY VALVE CONTROL	1	<=53276		NOT SALE	1.65	3.63
010	YR909-00100	ASSY VALVE CONTROL	1	>=53277	-		1.6	3.52
020	01123-50845	BOLT	1				0.02	0.044
030	01123-50850	BOLT	2				0.02	0.044
040	04817-00120	O RING	2				0.001	0.0022

CONTROL VALVE [NEW TYPE]

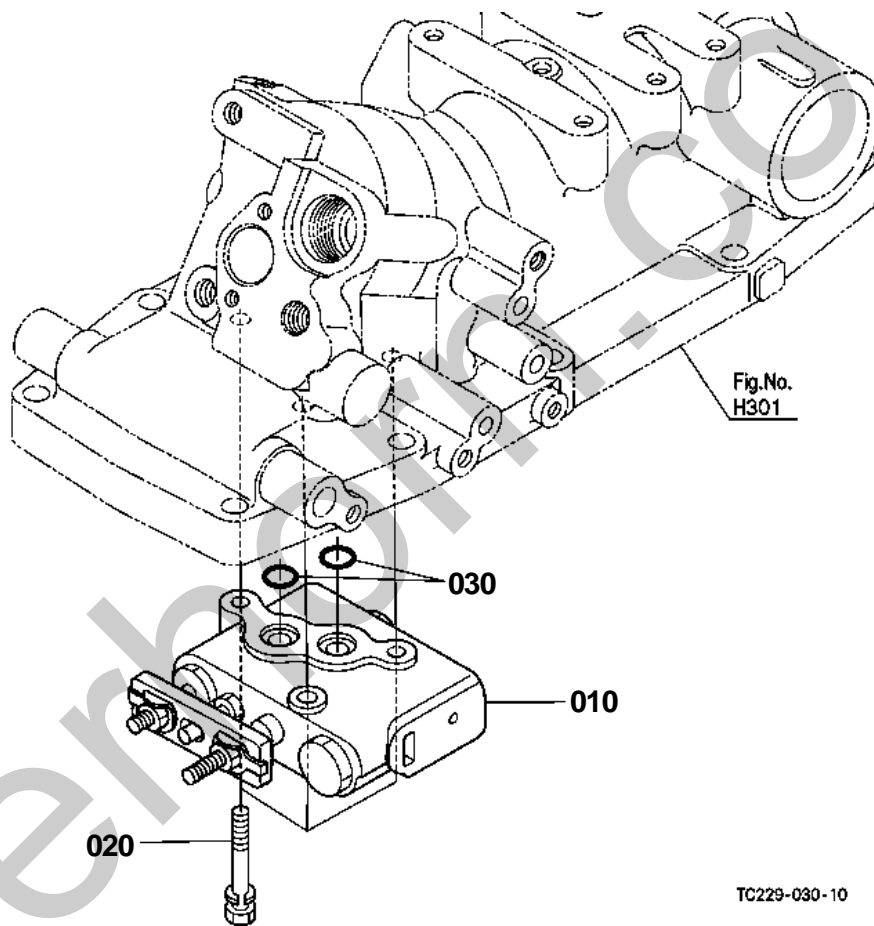

TC229-030-10



**CONTROL VALVE [NEW TYPE]**  
S.No.;>=57745

↔ Interchangeable; ≠ not interchangeable; ← new for old; → old for new

REF.No	Part No.	Description	Q'ty	S.No.	I/C	REMARKS	Weight (kgf)	Weight (lb)
010	31351-39604	ASSY VALVE CONTROL	1				1.9	4.18
020	01123-50850	BOLT	3				0.02	0.044
030	04817-00120	O RING	2				0.001	0.0022

CONTROL VALVE [COMPONENT PARTS] [OLD TYPE]

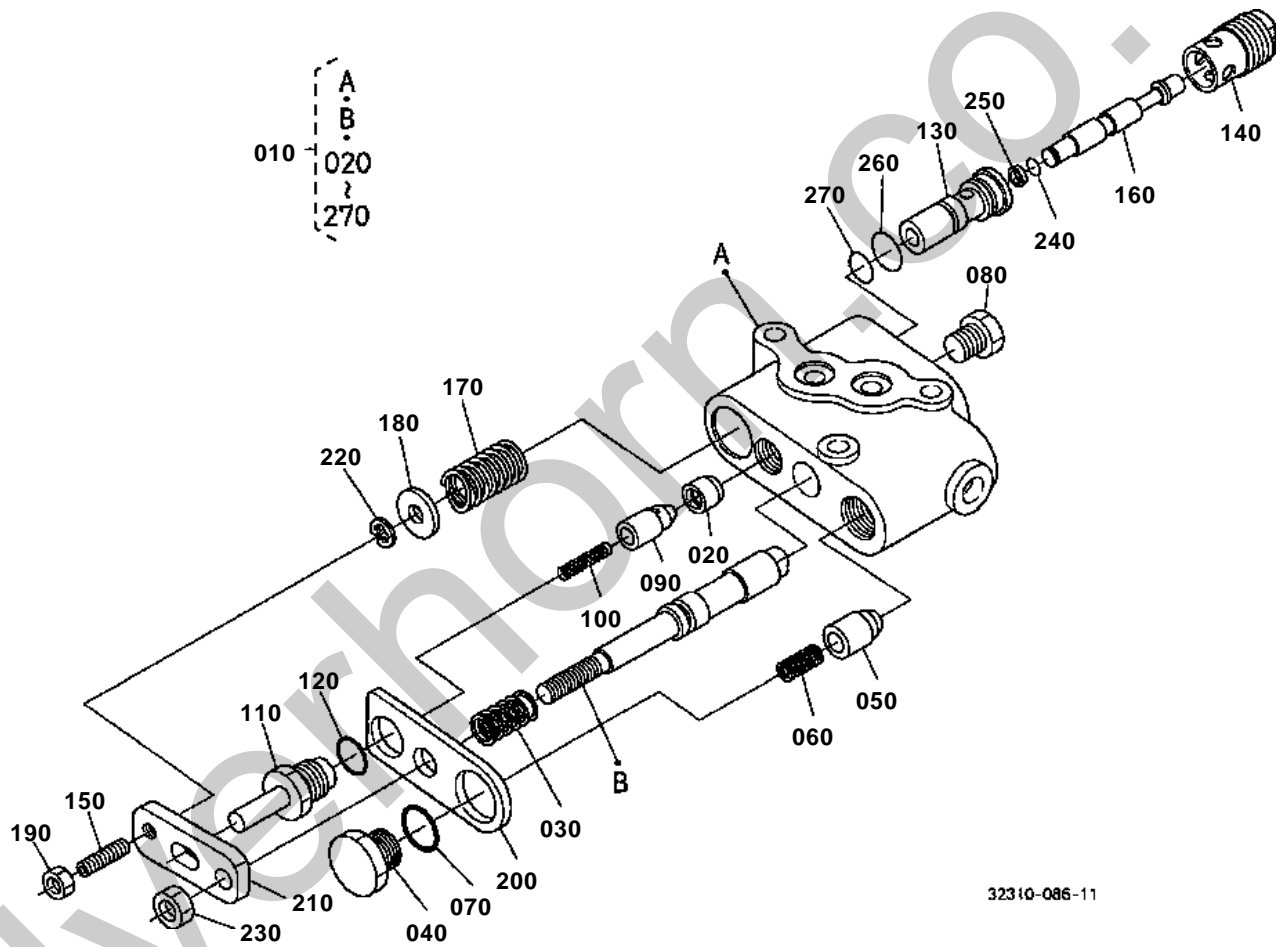

32310-086-11



**CONTROL VALVE [COMPONENT PARTS] [OLD TYPE]**  
S.No.;<=53276[NOTE:ORDER BY FIG.No.H405 REF.No.010 NEW PARTS.]

↔ Interchangeable; ≠ not interchangeable; ← new for old; → old for new

REF.No	Part No.	Description	Q'ty	S.No.	I/C	REMARKS	Weight (kgf)	Weight (lb)
010	31391-39002	ASSY VALVE CONTROL	1			NOT SALE SEE NOTE	1.65	3.63
020	T0430-37530	SEAT CHECK VALVE	1				0.005	0.011
030	31351-39130	SPRING SPOOL	1				0.005	0.011
040	31351-39140	PLUG	1				0.05	0.11
050	31351-39150	POPPET	1				0.02	0.044
060	67531-38470	SPRING	1				0.001	0.0022
070	04817-00160	O RING	1				0.001	0.0022
080	06331-35010	PLUG	1				0.012	0.0264
090	T0430-37580	POPPET	1				0.01	0.022
100	31391-39190	SPRING	1				0.001	0.0022
110	31351-37670	PLUG	1				0.038	0.0836
120	04817-00120	O RING	1				0.001	0.0022
130	T0430-37600	SLEEVE	1				0.05	0.11
140	31351-37620	PLUG	1				0.045	0.099
150	03650-50622	SCREW SET	1				0.004	0.0088
160	T0430-37610	POPPET	1				0.018	0.0396
170	T0430-37620	SPRING	1				0.009	0.0198
180	T0430-37640	WASHER PLAIN	1				0.002	0.0044
190	02014-50060	NUT	1				0.002	0.0044
200	31391-39240	PLATE	1				0.026	0.0572
210	31351-39752	PLATE	1				0.05	0.11
220	04613-50060	CIR CLIP EXTERNAL	1				0.001	0.0022
230	02114-50080	NUT	1				0.005	0.011
240	04816-00050	O RING	1				0.001	0.0022
250	31351-39290	RING BACK UP	1				0.001	0.0022
260	04817-05120	O RING	1				0.001	0.0022
270	04817-05110	O RING	1				0.005	0.011



CONTROL VALVE [COMPONENT PARTS] [NEW TYPE]

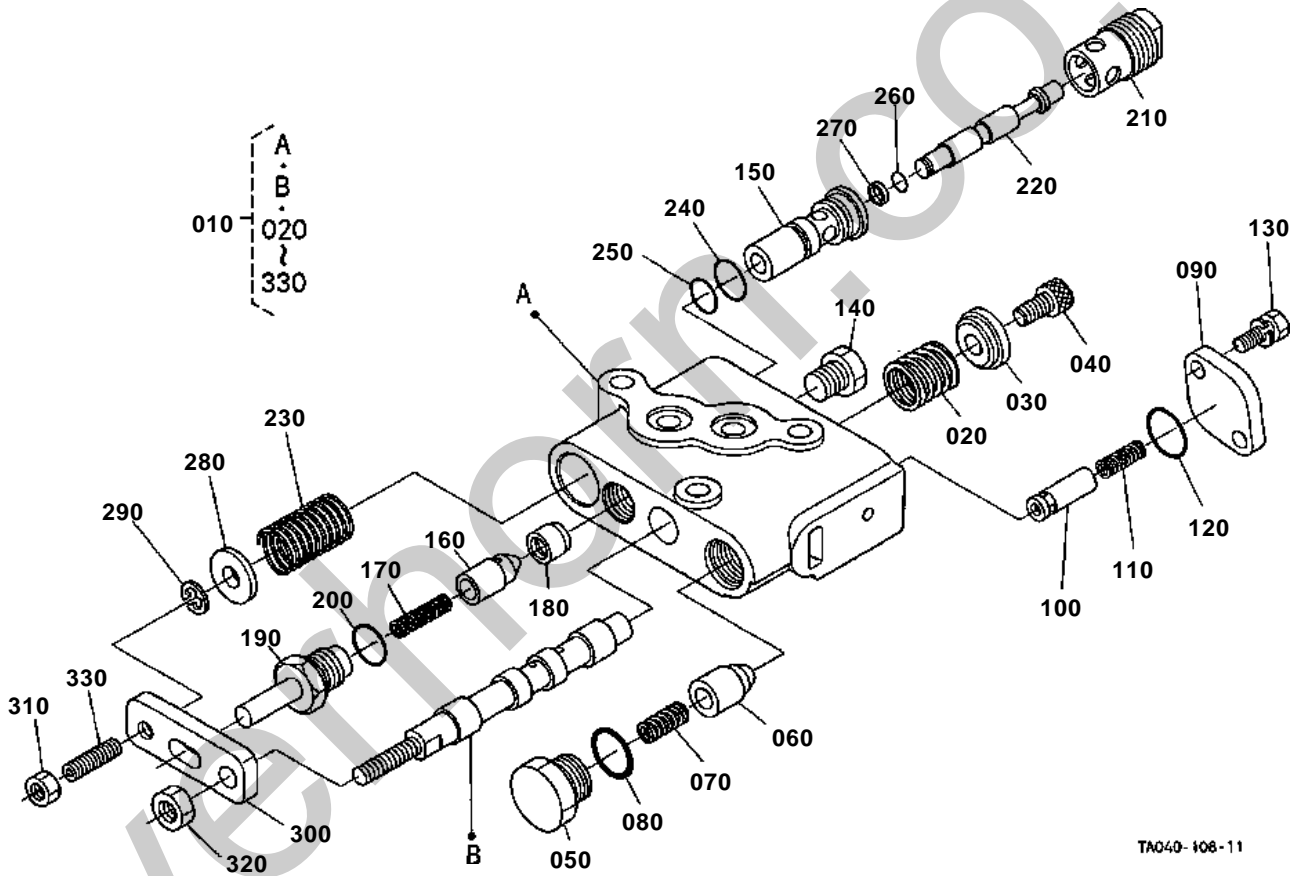

TA040-106-11

**CONTROL VALVE [COMPONENT PARTS] [NEW TYPE]**

S.No.;&gt;=57745

↔ Interchangeable; ≠ not interchangeable; ← new for old; → old for new

REF.No	Part No.	Description	Q'ty	S.No.	I/C	REMARKS	Weight (kgf)	Weight (lb)
010	31351-39604	ASSY VALVE CONTROL	1				1.9	4.18
020	31351-39630	SPRING SPOOL	1				0.02	0.044
030	31351-39640	HOLDER SPRING	1				0.02	0.044
040	01311-10814	BOLT HEX-SOC-HD	1				0.012	0.0264
050	31351-39650	PLUG	1				0.04	0.088
060	31351-39150	POPPET	1				0.02	0.044
070	67531-38470	SPRING	1				0.001	0.0022
080	04817-00140	O RING	1				0.001	0.0022
090	31351-39660	PLATE	1				0.05	0.11
100	31351-39670	POPPET	1				0.01	0.022
110	31351-39680	SPRING	1				0.01	0.022
120	04817-00160	O RING	1				0.001	0.0022
130	01023-50616	BOLT	2				0.005	0.011
140	06331-35010	PLUG	1				0.012	0.0264
150	T0430-37600	SLEEVE	1				0.05	0.11
160	T0430-37580	POPPET	1				0.01	0.022
170	31391-39190	SPRING	1				0.001	0.0022
180	T0430-37530	SEAT CHECK VALVE	1				0.005	0.011
190	31351-37670	PLUG	1				0.038	0.0836
200	04817-00120	O RING	1				0.001	0.0022
210	31351-37620	PLUG	1				0.045	0.099
220	T0430-37610	POPPET	1				0.018	0.0396
230	T0430-37620	SPRING	1				0.009	0.0198
240	04817-05120	O RING	1				0.001	0.0022
250	04817-05110	O RING	1				0.005	0.011
260	04816-00050	O RING	1				0.001	0.0022
270	31351-39290	RING BACK UP	1				0.001	0.0022
280	T0430-37640	WASHER PLAIN	1				0.002	0.0044
290	04613-50060	CIR CLIP EXTERNAL	1				0.001	0.0022
300	31351-39752	PLATE	1				0.05	0.11
310	02014-50060	NUT	1				0.002	0.0044
320	02114-50080	NUT	1				0.005	0.011
330	03650-50622	SCREW SET	1				0.004	0.0088

POSITION CONTROL LEVER

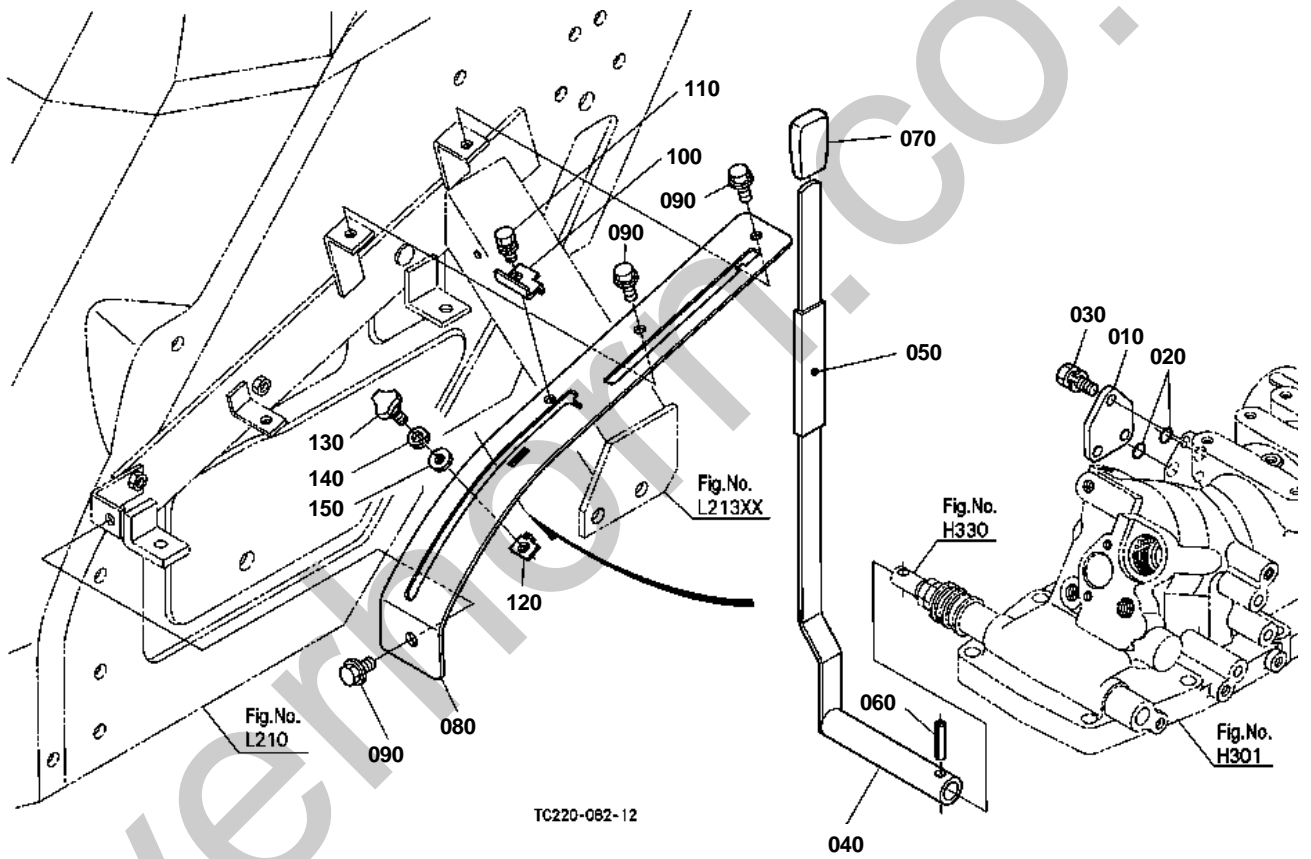

## OLD PARTS

S. No. A:<=10603, B:<=53276  
C:<=10398, D:<=55651

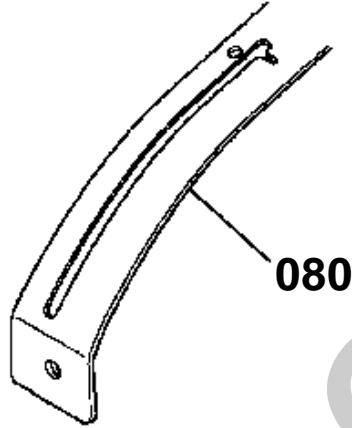

S. No. A:<=10866, B:<=57222  
C:<=10509, D:<=60965

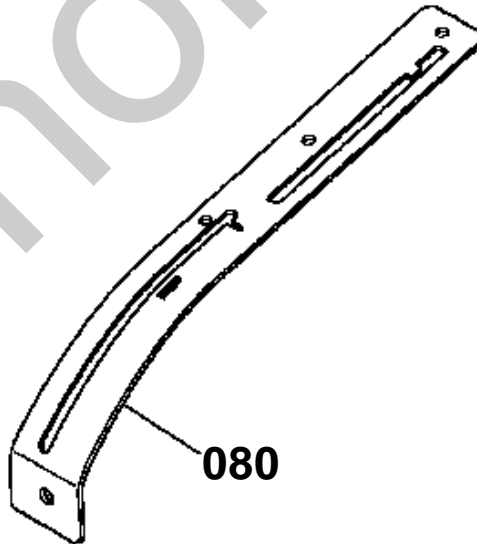

TC220-841-11



# POSITION CONTROL LEVER

↔ Interchangeable; ≠ not interchangeable; ← new for old; → old for new

REF.No	Part No.	Description	Q'ty	S.No.	I/C	REMARKS	Weight (kgf)	Weight (lb)
010	32430-41210	COVER CYL.SIDE RH	1				0.11	0.242
020	04817-00140	O RING	2				0.001	0.0022
030	01123-50820	BOLT	3				0.011	0.0242
040	TC220-36850	LEVER POSITION	1				0.56	1.232
050	TA040-36132	TUBE LEVER	1				0.01	0.022
060	05411-00525	PIN SPRING	1				0.002	0.0044
070	52300-32640	GRIP LEVER	1				0.04	0.088
080	TC220-47600	GUIDE HYD.LEVER	1	<=53276			0.43	0.946
080	TC220-47602	GUIDE HYD.LEVER	1	>=53277	-		0.43	0.946
080	TC220-47603	GUIDE HYD.LEVER	1	>=57223	-		0.43	0.946
090	01754-50816	BOLT FLANGE	3				0.011	0.0242
100	34070-36130	STOPPER	1				0.015	0.033
110	01123-60816	BOLT	1				0.01	0.022
120	34070-36140	STOPPER	1				0.005	0.011
130	37410-52610	SCREW KNOB	1				0.015	0.033
140	04512-60060	WASHER SPRING	1				0.001	0.0022
150	31351-18860	WASHER	1				0.002	0.0044

TOP LINK

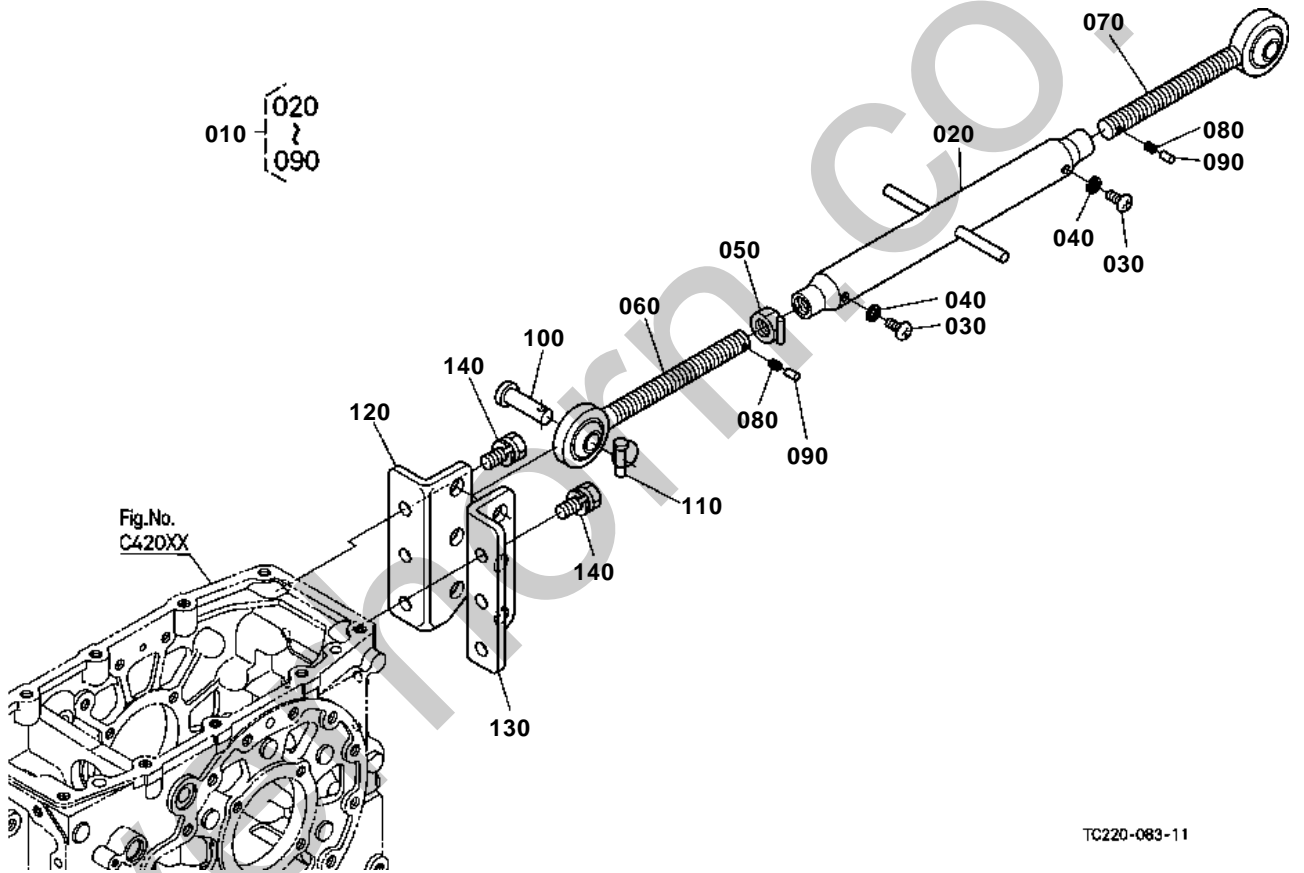

**TOP LINK**

↔ Interchangeable; ≠ not interchangeable; ← new for old; → old for new

REF.No	Part No.	Description	Q'ty	S.No.	I/C	REMARKS	Weight (kgf)	Weight (lb)
010	32310-71100	ASSY LINK TOP	1				2.8	6.16
020	31341-71110	LINK TOP	1				1.1	2.42
030	31351-71150	SCREW	2				0.018	0.0396
040	04512-60060	WASHER SPRING	2				0.001	0.0022
050	38247-71180	NUT TOP LINK	1				0.06	0.132
060	34670-71210	JOINT TOP LINK RH	1				0.86	1.892
070	34670-71220	JOINT TOP LINK LH	1				0.83	1.826
080	70436-58360	SPRING	2				0.001	0.0022
090	31351-71160	PIN	2				0.002	0.0044
100	31150-71360	PIN JOINT	2				0.166	0.3652
110	34150-37640	PIN SET	2				0.06	0.132
120	99571-22140	HOLDER TOP LINK RH	1				0.96	2.112
130	99571-22150	HOLDER TOP LINK LH	1				0.99	2.178
140	01133-51230	BOLT	6				0.04	0.088

3-POINT LINKAGE 1 (LOWER LINK)

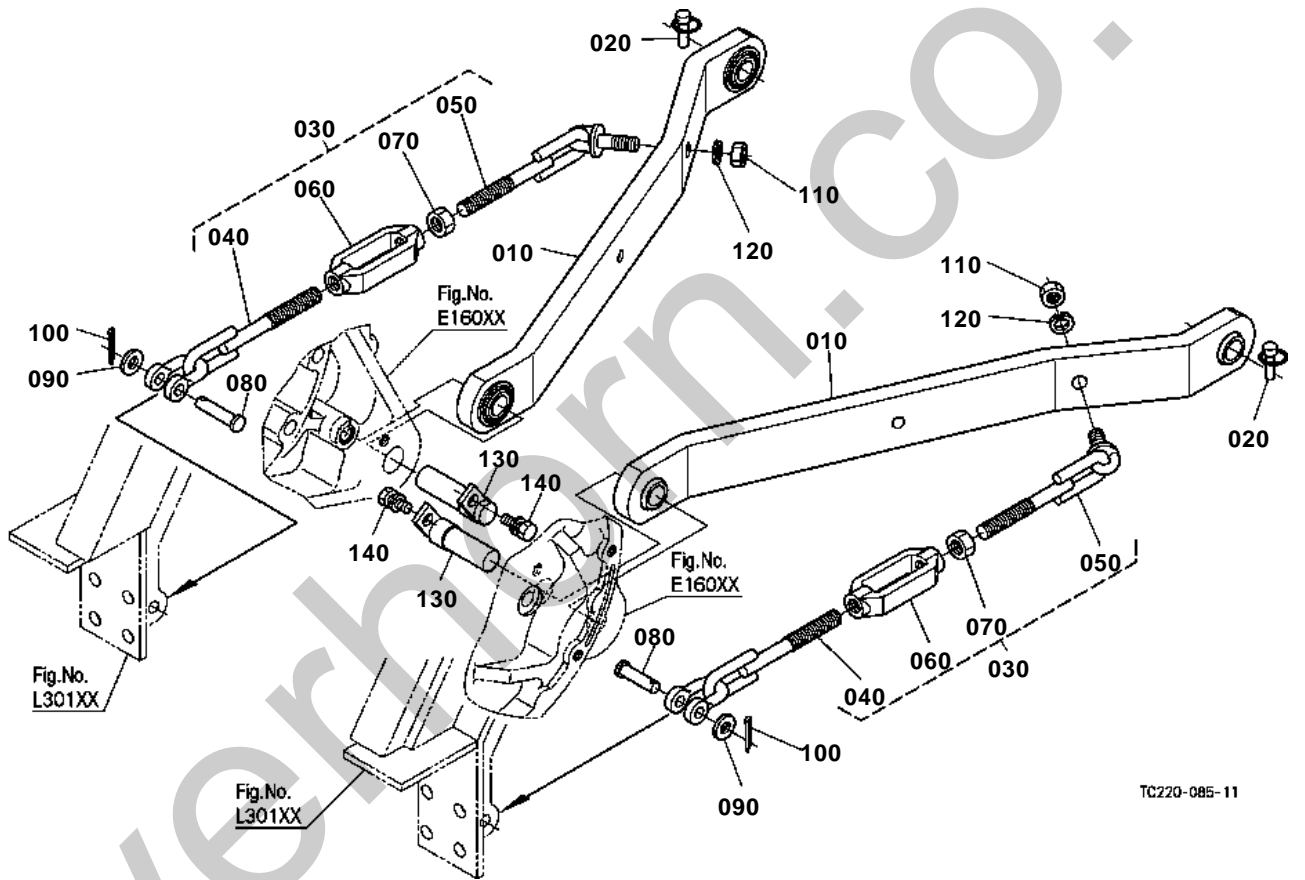

TC220-085-11





### 3-POINT LINKAGE 1 (LOWER LINK)

↔ Interchangeable; ≠ not interchangeable; ← new for old; → old for new

REF.No	Part No.	Description	Q'ty	S.No.	I/C	REMARKS	Weight (kgf)	Weight (lb)
010	TC220-71330	COMP.LINK LOWER	2				8.1	17.82
020	34150-37640	PIN SET	2				0.06	0.132
030	TC220-39700	ASSY CHAIN CHECK	2				1.295	2.849
040	T1270-39710	CHAIN CHECK	2				0.46	1.012
050	T1230-39720	CHAIN CHECK	2				0.445	0.979
060	T1270-39730	TURNBUCKLE	2				0.37	0.814
070	02052-50160	NUT	2				0.025	0.055
080	32353-71890	PIN	2				0.041	0.0902
090	04013-60120	WASHER PLAIN	2				0.01	0.022
100	05511-50425	PIN SPLIT	2				0.003	0.0066
110	02074-50160	NUT	2				0.029	0.0638
120	04512-60160	WASHER SPRING	2				0.01	0.022
130	TA040-39412	PIN LOWER LINK	2				0.25	0.55
140	01133-51020	BOLT	2				0.02	0.044

3-POINT LINKAGE 2 (LIFT ROD)

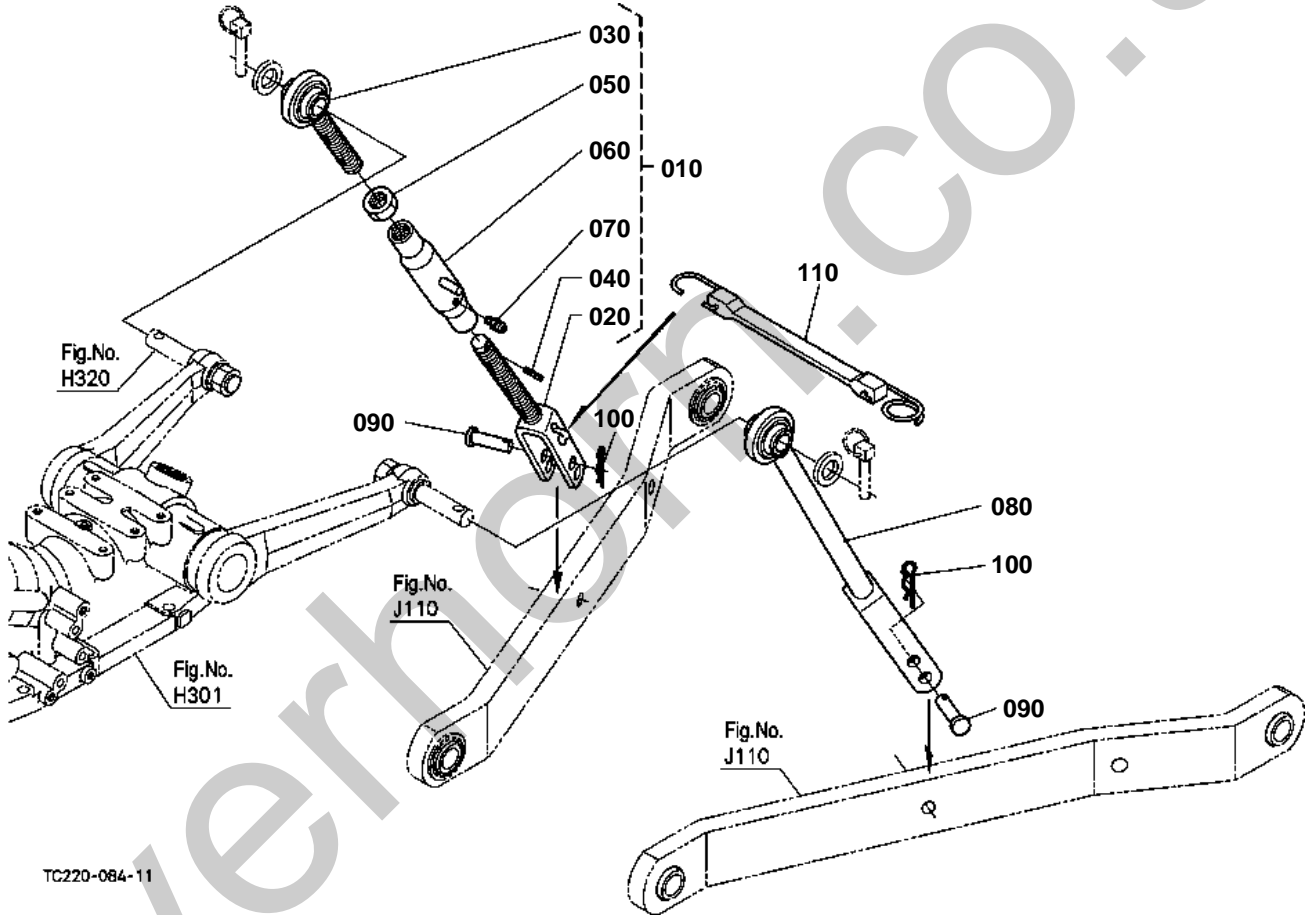

TC220-084-11



### 3-POINT LINKAGE 2 (LIFT ROD)

↔ Interchangeable; ≠ not interchangeable; ← new for old; → old for new

REF.No	Part No.	Description	Q'ty	S.No.	I/C	REMARKS	Weight (kgf)	Weight (lb)
010	TC220-71562	ASSY ROD LIFT RH	1				2.2	4.84
020	TC220-71522	ROD LIFT LOWER	1				0.87	1.914
030	31331-71510	ROD LIFT UPPER	1				0.58	1.276
040	05411-00320	PIN SPRING	1				0.001	0.0022
050	35110-71570	NUT	1				0.05	0.11
060	38187-71770	ROD LIFT MIDDLE	1				0.54	1.188
070	06613-10675	NIPPLE GREASE	1				0.003	0.0066
080	TC220-71540	ROD LIFT LH	1	<=52580			0	0
080	TC220-71542	ROD LIFT LH	1	>=52581	-		1.56	3.432
090	38687-71582	PIN LIFT ROD	2				0.08	0.176
100	05515-51600	PIN SNAP	2				0.007	0.0154
110	35080-71750	COMP.RUBBER	1				0.065	0.143

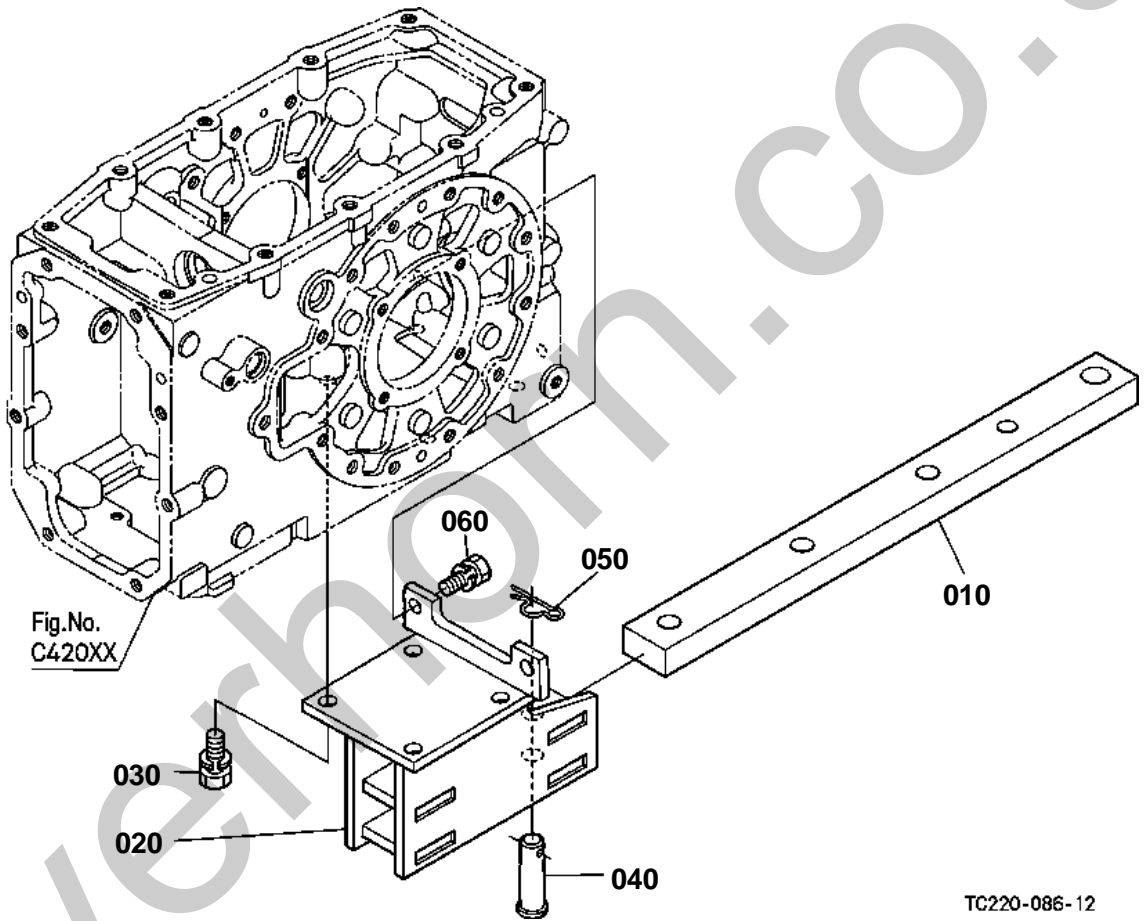



# DRAWBAR

↔ Interchangeable; ≠ not interchangeable; ← new for old; → old for new

REF.No	Part No.	Description	Q'ty	S.No.	I/C	REMARKS	Weight (kgf)	Weight (lb)
010	TC220-29710	DRAWBAR	1				7	15.4
020	TC220-29730	FRAME DRAWBAR	1				6.2	13.64
030	01138-51430	BOLT	4				0.07	0.154
040	05122-52070	PIN JOINT	1				0.184	0.4048
050	05515-51600	PIN SNAP	1				0.007	0.0154
060	01133-51230	BOLT	2				0.04	0.088

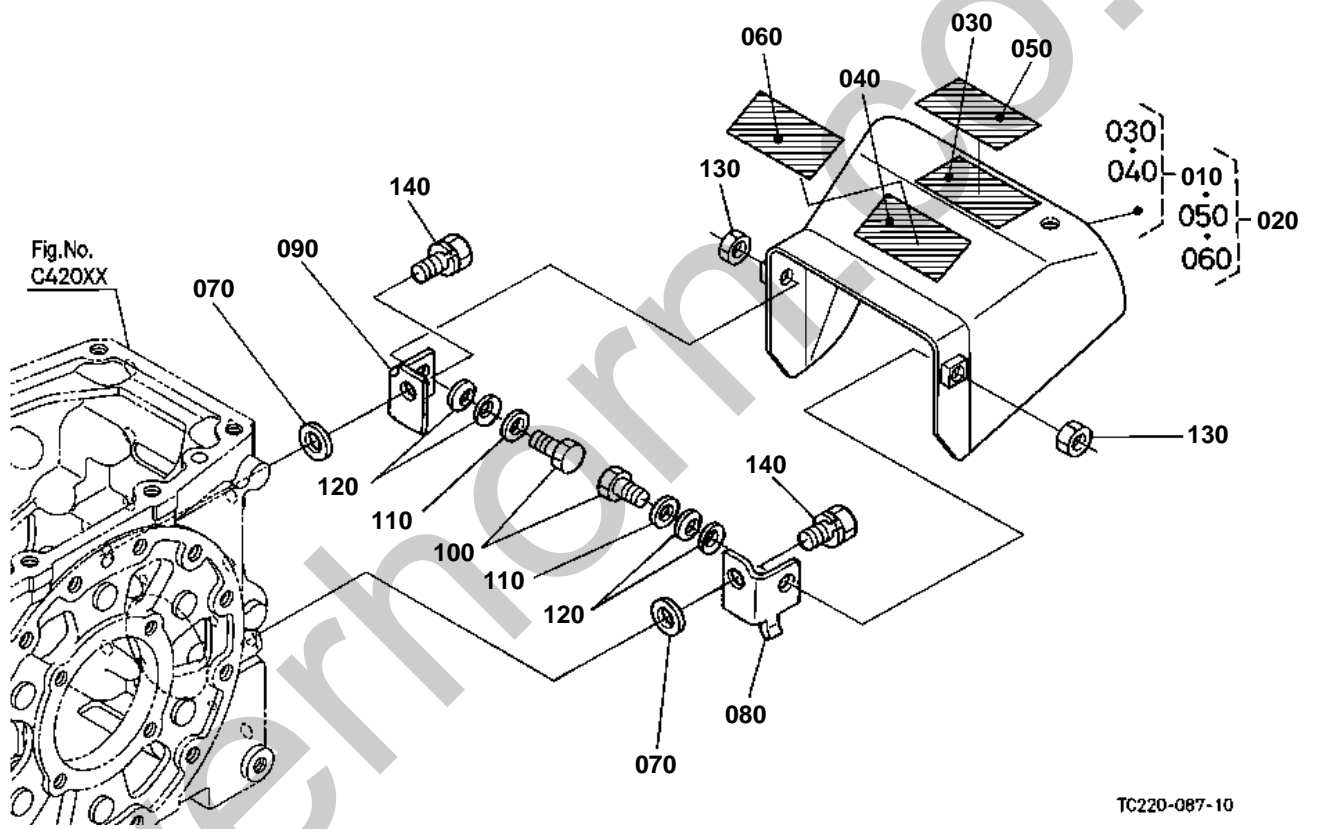



# PTO PROTECTOR

↔ Interchangeable; ≠ not interchangeable; ← new for old; → old for new

REF.No	Part No.	Description	Q'ty	S.No.	I/C	REMARKS	Weight (kgf)	Weight (lb)
010	TC220-99630	KIT COVER PTO(A)	1			ENGLISH	1.6	3.52
020	TC210-99630	KIT COVER PTO(B)	1			FRENCH	0	0
030	TA040-49593	LABEL PTO WARNING	1			ENGLISH	0.001	0.0022
040	TA040-49350	LABEL DRAWBAR	1			ENGLISH	0.002	0.0044
050	TA041-49590	LABEL PTO WARNING	1			FRENCH	0.001	0.0022
060	TA041-49350	LABEL DRAWBAR	1			FRENCH	0.003	0.0066
070	35114-25340	COLLAR	2				0.02	0.044
080	TA020-23752	STAY	1				0.12	0.264
090	TA020-23762	STAY	1				0.001	0.0022
100	01173-51025	BOLT	2				0.021	0.0462
110	04013-60100	WASHER PLAIN	2				0.003	0.0066
120	62151-42412	SPRING PLATE	4				0.002	0.0044
130	02116-50100	NUT	2				0.004	0.0088
140	01133-51230	BOLT	2				0.04	0.088

FRONT GRILLE

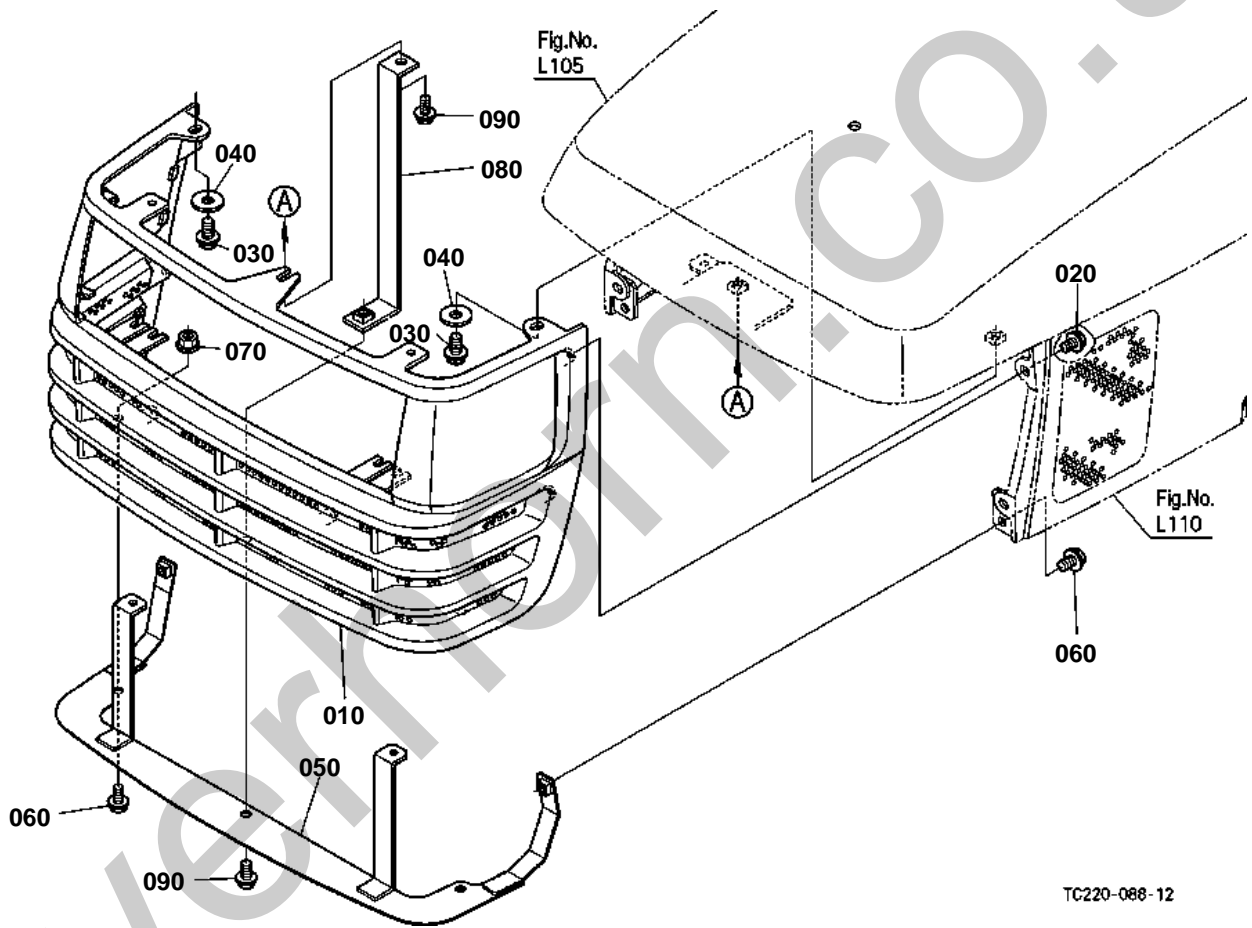

TC220-088-12



OLD PARTS

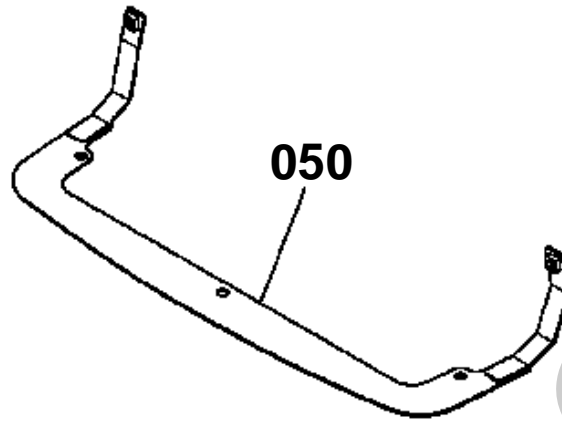

050

Silverhorn.CO.UK

TC230-800-10



# FRONT GRILLE

↔ Interchangeable; ≠ not interchangeable; ← new for old; → old for new

REF.No	Part No.	Description	Q'ty	S.No.	I/C	REMARKS	Weight (kgf)	Weight (lb)
010	TC220-41820	ASSY GRILLE BONNET	1				1.1	2.42
020	01754-50612	BOLT FLANGE	4				0.005	0.011
030	01754-50816	BOLT FLANGE	2				0.011	0.0242
040	04015-60080	WASHER PLAIN	2				0.01	0.022
050	TC220-41842	BASE GRILLE	1	<=52580			0.5	1.1
050	TC220-41843	BASE GRILLE	1	>=52581	1		0.5	1.1
060	01754-50816	BOLT FLANGE	4				0.011	0.0242
070	02751-50080	NUT FLANGE	2				0.006	0.0132
080	TC220-41850	SUPPORT BONNET	1				0.21	0.462
090	01754-50816	BOLT FLANGE	2				0.011	0.0242

HOOD(BONNET) FRONT SUPPORT [EXCEPT HST TYPE]

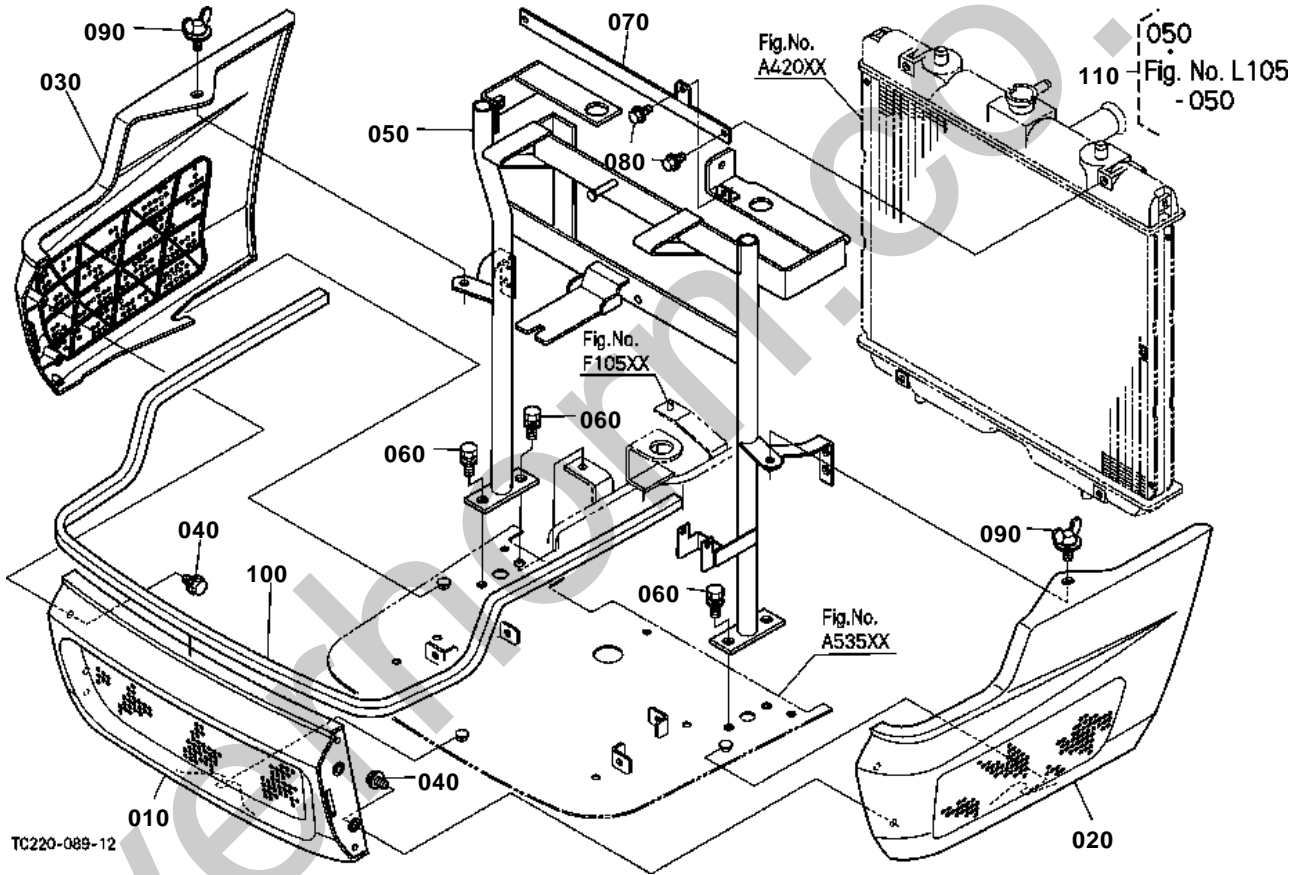

OLD PARTS

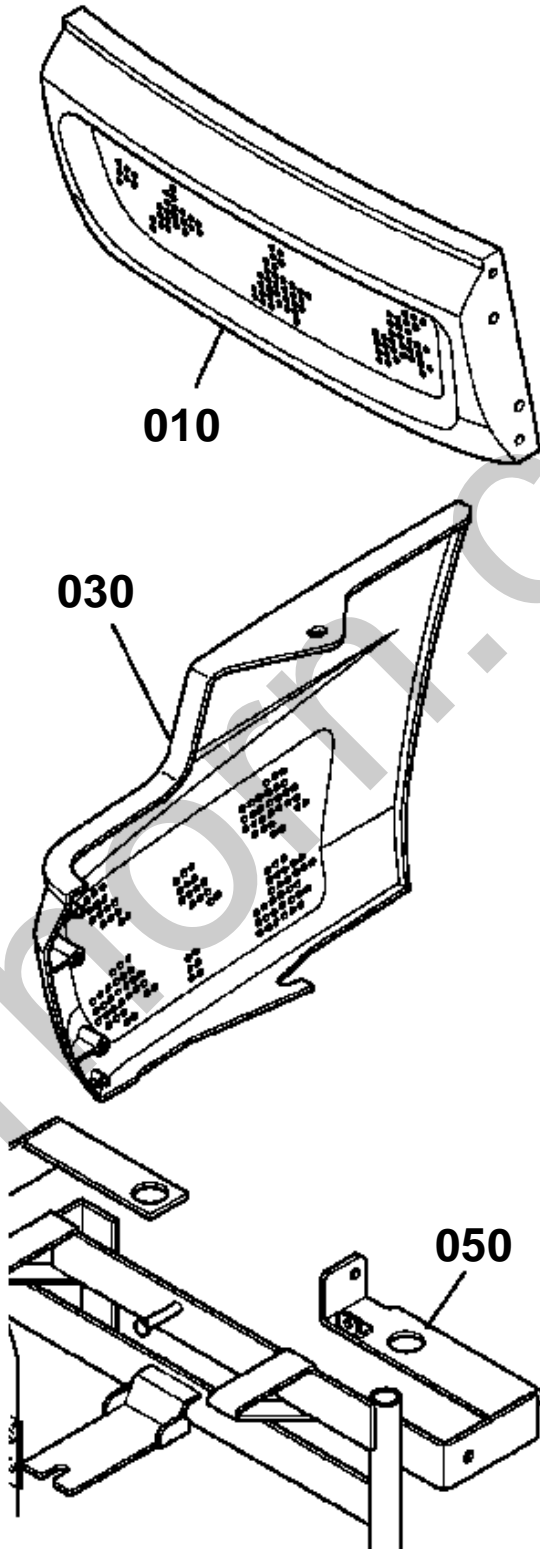

TC220-817-11



HOOD(BONNET) FRONT SUPPORT [EXCEPT HST TYPE]

↔ Interchangeable; ≠ not interchangeable; ← new for old; → old for new

REF.No	Part No.	Description	Q'ty	S.No.	I/C	REMARKS	Weight (kgf)	Weight (lb)
010	TC220-41060	BONNET FRONT UNDER	1	≤50684		RED	0	0
010	TC220-41062	BONNET FRONT UNDER	1	≥50685	┘	RED	0.405	0.891
010	TC230-41060	BONNET UNDER	1	≥52581	┘	BLACK	0.385	0.847
010	TC230-41062	BONNET UNDER	1	≥57745	┘	BLACK	0.385	0.847
020	TC220-41080	ASSY BONNET FRONT LH	1	≤50684		RED	0.45	0.99
020	TC220-41082	ASSY BONNET FRONT LH	1	≥50685	┘	RED	0.45	0.99
020	TC230-41080	BONNET FRONT LH	1	≥52581	┘	BLACK	0.43	0.946
020	TC230-41082	BONNET FRONT LH	1	≥57745	┘	BLACK	0.43	0.946
030	TC220-41090	ASSY BONNET FRONT RH	1	≤50684		RED	0.45	0.99
030	TC220-41092	ASSY BONNET FRONT RH	1	≥50685	┘	RED	0.45	0.99
030	TC230-41090	BONNET FRONT RH	1	≥52581	┘	BLACK	0.43	0.946
030	TC230-41092	BONNET FRONT RH	1	≥57745	┘	BLACK	0.43	0.946
040	01754-50612	BOLT FLANGE	4				0.005	0.011
050	TC220-18312	SUPPORT FRONT	1	≤52262		NOT SALE ORDER BY REF.No.110	4	8.8
050	TC220-18314	SUPPORT FRONT	1	≥52263	┘		4	8.8
050	TC220-18316	SUPPORT FRONT	1	≥53882	┘		4	8.8
060	01133-51025	BOLT	4				0.023	0.0506
070	TC220-18320	BRACKET	1				0.12	0.264
080	01754-50612	BOLT FLANGE	3				0.005	0.011
090	TC220-41390	BOLT WING	2				0.036	0.0792
100	TC220-41072	SPONGE BONNET LOWER	1	≤52427			0	0
100	TC230-41070	SPONGE BONNET LOWER	1	≥52428	┘		0.04	0.088
110	TC220-98310	KIT PILLAR FRONT	1	≤52262			0	0

HOOD(BONNET) FRONT SUPPORT [HST TYPE]

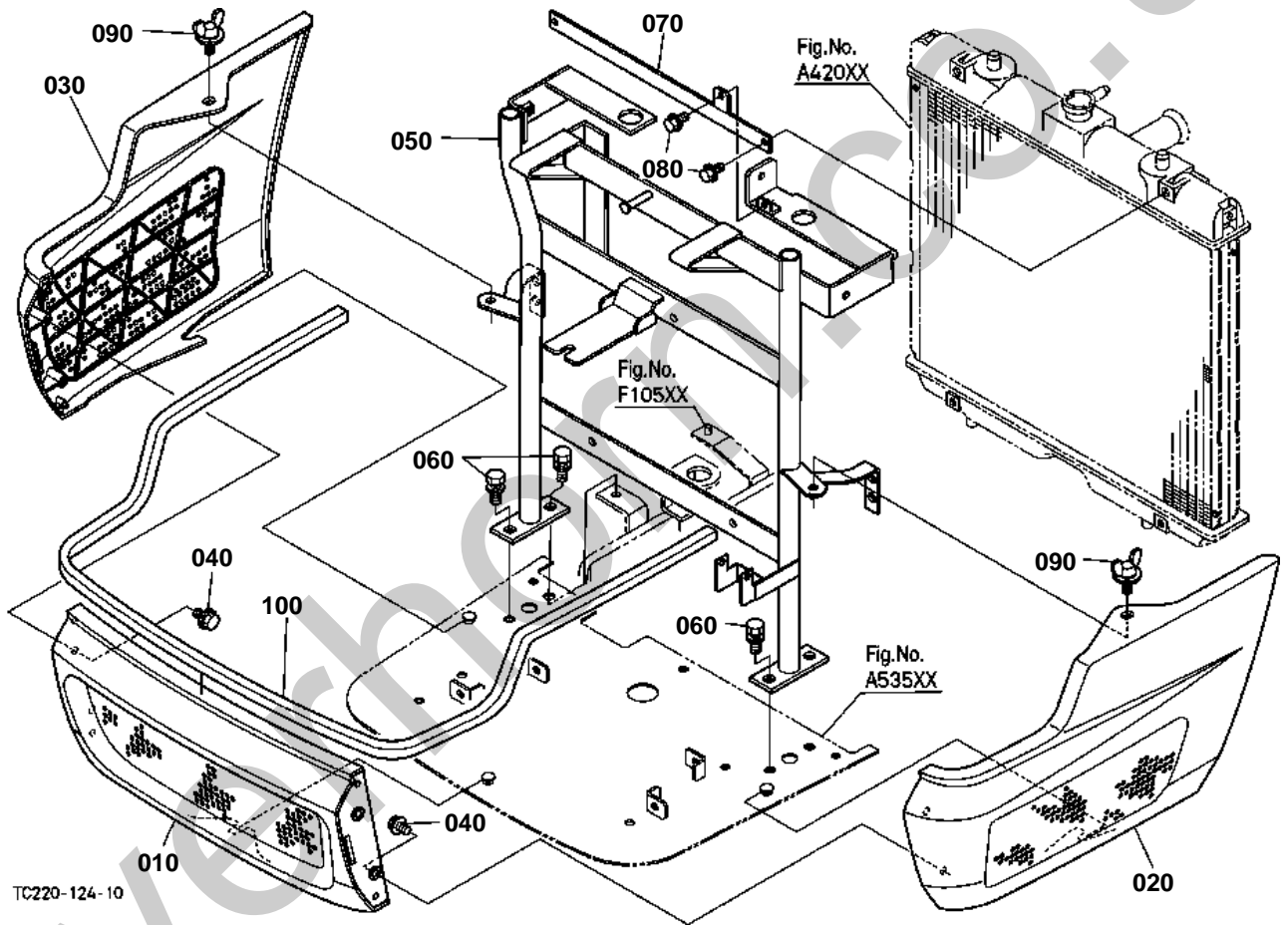



# HOOD(BONNET) FRONT SUPPORT [HST TYPE]

↔ Interchangeable; ≠ not interchangeable; ← new for old; → old for new

REF.No	Part No.	Description	Q'ty	S.No.	I/C	REMARKS	Weight (kgf)	Weight (lb)
010	TC230-41060	BONNET UNDER	1	<=57744			0.385	0.847
010	TC230-41062	BONNET UNDER	1	>=57745	-		0.385	0.847
020	TC230-41080	BONNET FRONT LH	1	<=57744			0.43	0.946
020	TC230-41082	BONNET FRONT LH	1	>=57745	-		0.43	0.946
030	TC230-41090	BONNET FRONT RH	1	<=57744			0.43	0.946
030	TC230-41092	BONNET FRONT RH	1	>=57745	-		0.43	0.946
040	01754-50612	BOLT FLANGE	4				0.005	0.011
050	TC220-57203	SUPPORT FRONT	1				0	0
060	01133-51025	BOLT	4				0.023	0.0506
070	TC220-18320	BRACKET	1				0.12	0.264
080	01754-50612	BOLT FLANGE	3				0.005	0.011
090	TC220-41390	BOLT WING	2				0.036	0.0792
100	TC230-41070	SPONGE BONNET LOWER	1				0.04	0.088

HOOD(BONNET)

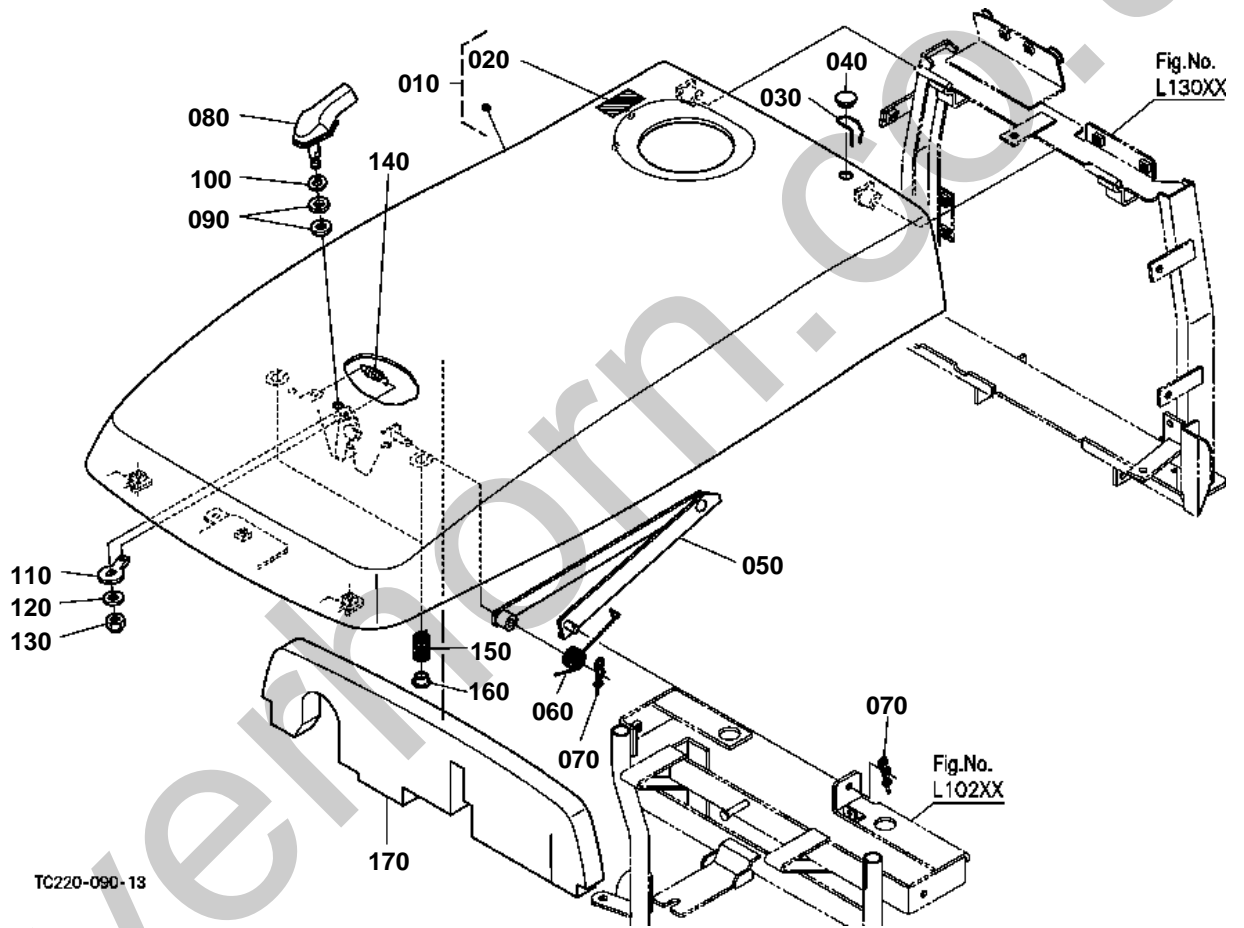



## OLD PARTS

S.No. ; A :  $\leq 10450$   
, B ;  $\leq 51997$   
, C ;  $\leq 10294$   
, D ;  $\leq 53223$

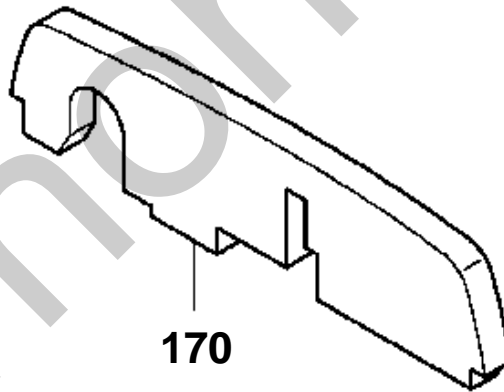
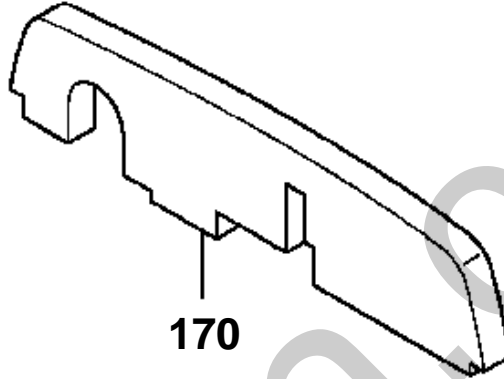

TC220-836-10

**HOOD(BONNET)**

↔ Interchangeable; ≠ not interchangeable; ← new for old; → old for new

REF.No	Part No.	Description	Q'ty	S.No.	I/C	REMARKS	Weight (kgf)	Weight (lb)
010	TC220-18700	KIT BONNET	1	<=52580			0	0
010	TC220-18702	KIT BONNET	1	>=52581	-		7.7	16.94
020	TA040-49562	LABEL	1				0.002	0.0044
030	3A011-83600	PIN SNAP	1				0.002	0.0044
040	3A111-83750	PLUG	1				0.002	0.0044
050	TC220-41230	LINK	1	<=52262			0.53	1.166
050	TC230-41230	LINK	1	>=52263	1		0	0
060	TC220-41262	SPRING LINK	1				0.02	0.044
070	52300-34120	PIN SNAP	2				0.001	0.0022
080	T0070-41560	HANDLE MASCOT	1				0.085	0.187
090	33251-83850	WASHER HANDLE	1	<=57744			0.001	0.0022
090	33251-83850	WASHER HANDLE	2	>=57745			0.001	0.0022
100	33251-83950	WASHER SPRING	1				0.001	0.0022
110	T1060-41220	LOCK BONNET	1				0.022	0.0484
120	04013-60080	WASHER PLAIN	1				0.002	0.0044
130	02552-50080	NUT LOCK	1				0.005	0.011
140	T1060-41120	SPRING	1				0.006	0.0132
150	T1060-41130	SPRING	2				0.022	0.0484
160	T1270-41140	CUSHION	2				0.007	0.0154
170	TC220-42314	SPONGE BONNET UPPER	1	<=51997			0	0
170	TC220-42315	SPONGE BONNET UPPER	1	>=51998	-		0.34	0.748
170	TC220-42316	SPONGE BONNET UPPER	1	>=52581	-		0.34	0.748

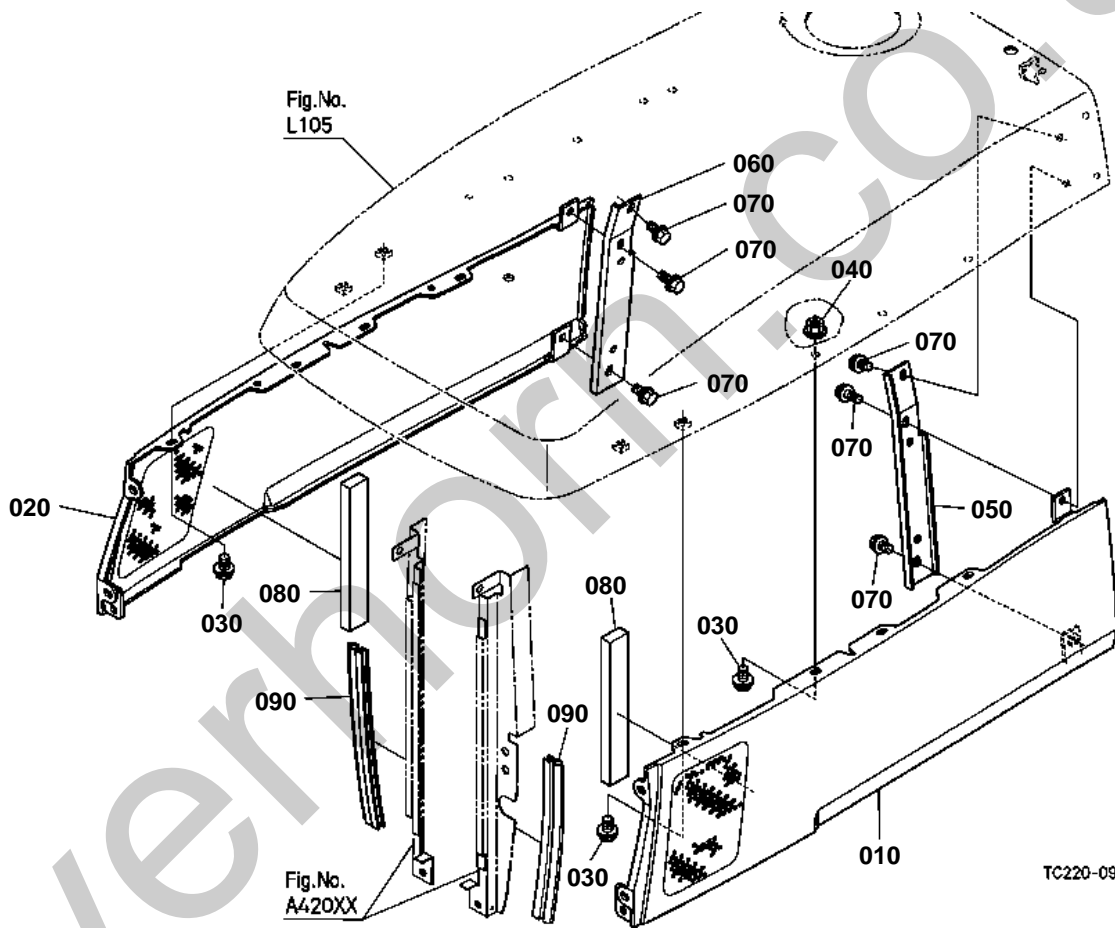

TC220-091-20



## HOOD(BONNET) SIDE

↔ Interchangeable; ≠ not interchangeable; ← new for old; → old for new

REF.No	Part No.	Description	Q'ty	S.No.	I/C	REMARKS	Weight (kgf)	Weight (lb)
010	TC220-41320	BONNET SIDE LH	1	<=53881			0	0
010	TC220-41323	BONNET SIDE LH	1	>=53882	-		1.42	3.124
020	TC220-41330	BONNET SIDE RH	1	<=53881			1.42	3.124
020	TC220-41333	BONNET SIDE RH	1	>=53882	-		1.42	3.124
030	01754-50812	BOLT FLANGE	8				0.01	0.022
040	02751-50080	NUT FLANGE	6				0.006	0.0132
050	TC220-41450	BRACKET	1				0.343	0.7546
060	TC220-41460	BRACKET	1				0.343	0.7546
070	01754-50612	BOLT FLANGE	6				0.005	0.011
080	TC220-42330	SPONGE BONNET SIDE	2	<=52580			0.013	0.0286
080	TC220-42332	SPONGE BONNET SIDE	2	>=52581	-		0.013	0.0286
090	TC220-42220	SHIELD	2				0.035	0.077

HOOD(BONNET) SIDE COVER

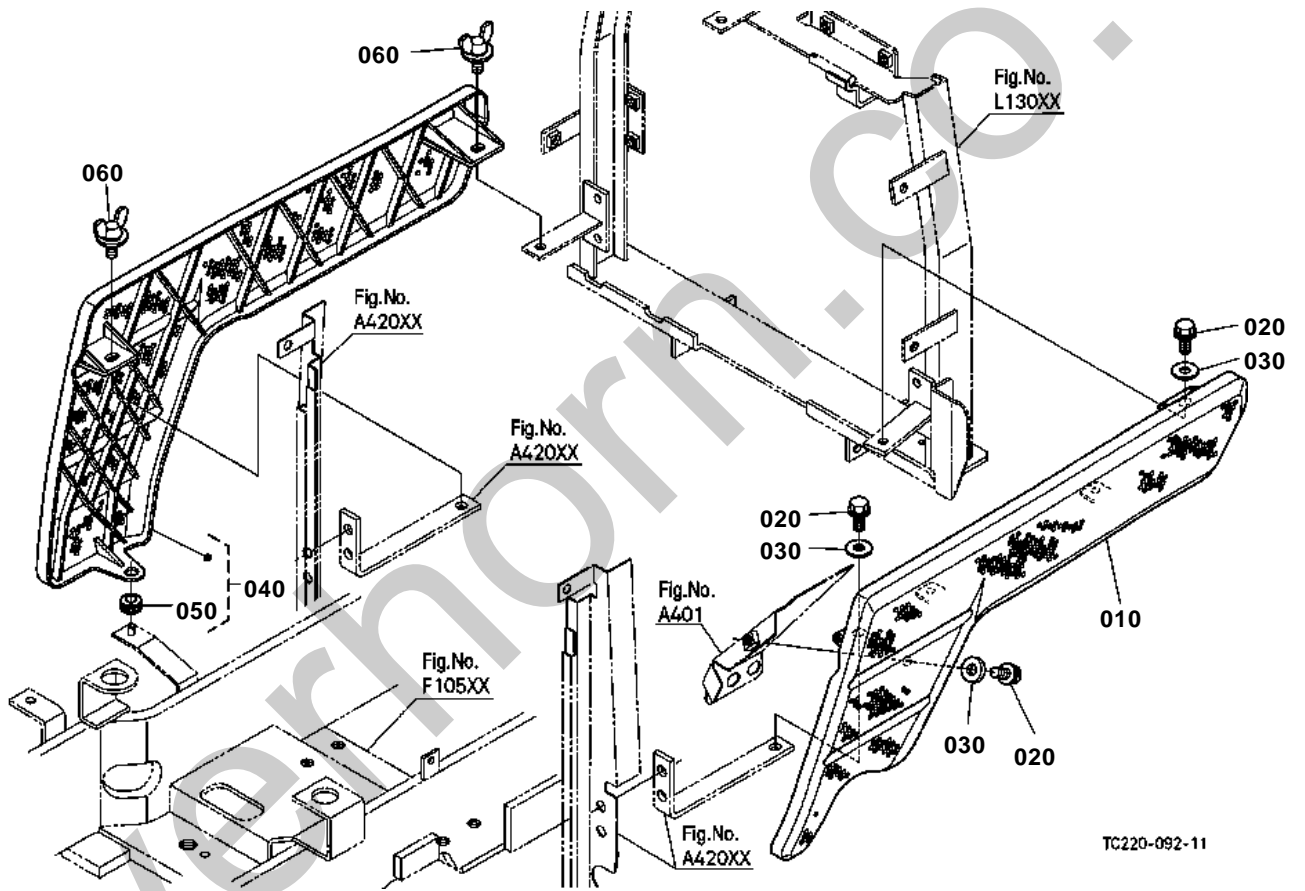

TC220-092-11



# HOOD(BONNET) SIDE COVER

↔ Interchangeable; ≠ not interchangeable; ← new for old; → old for new

REF.No	Part No.	Description	Q'ty	S.No.	I/C	REMARKS	Weight (kgf)	Weight (lb)
010	TC220-41350	COVER	1	<=52427			0.24	0.528
010	TC220-41352	COVER	1	>=52428	-		0.24	0.528
020	01754-50820	BOLT FLANGE	3				0.015	0.033
030	04015-60080	WASHER PLAIN	3				0.01	0.022
040	TC220-41340	ASSY COVER RH	1				0	0
050	66591-54580	RUBBER RELEASE ROD	1				0.002	0.0044
060	TC220-41390	BOLT WING	2				0.036	0.0792

SHUTTER PLATE [EXCEPT HST TYPE]

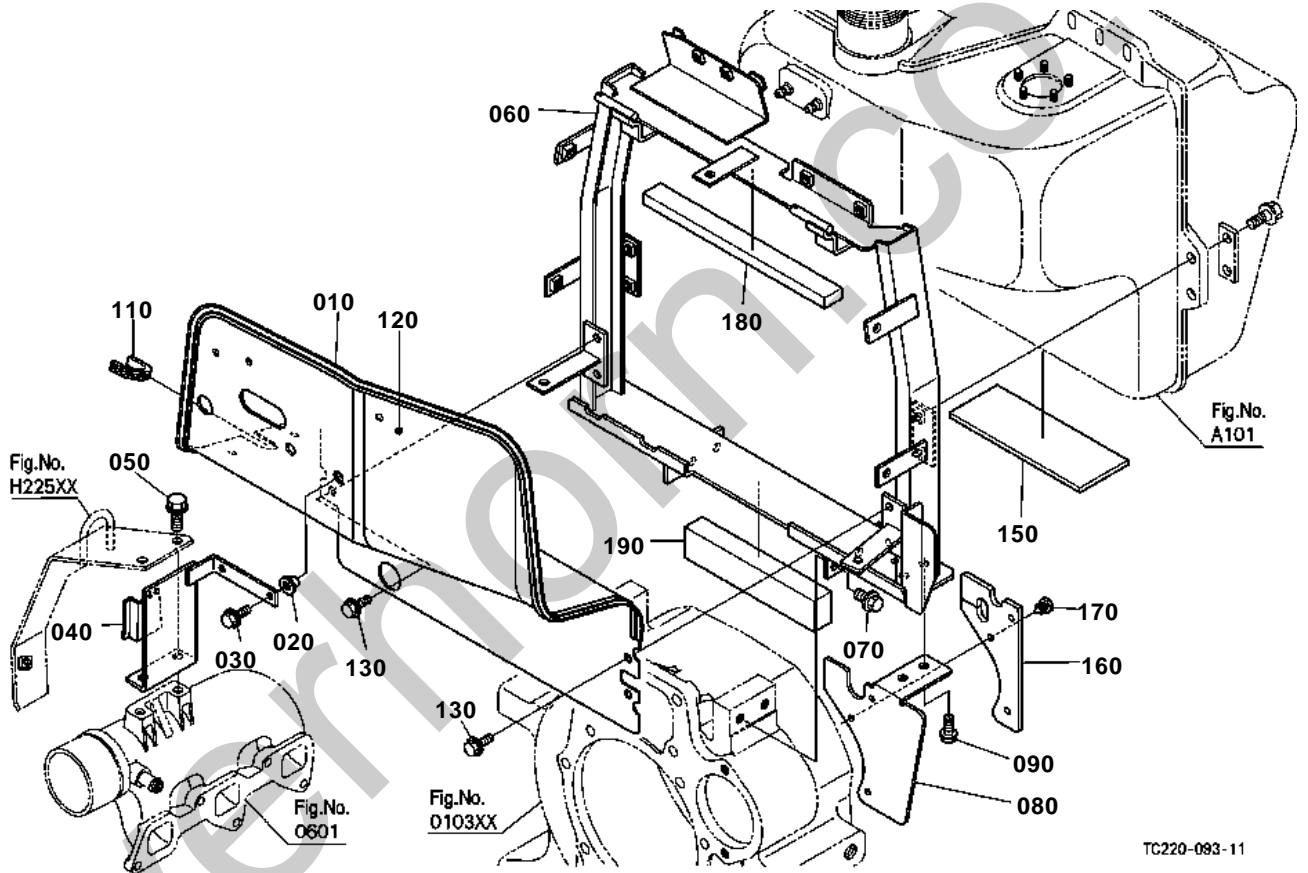

TC220-093-11

# OLD PARTS

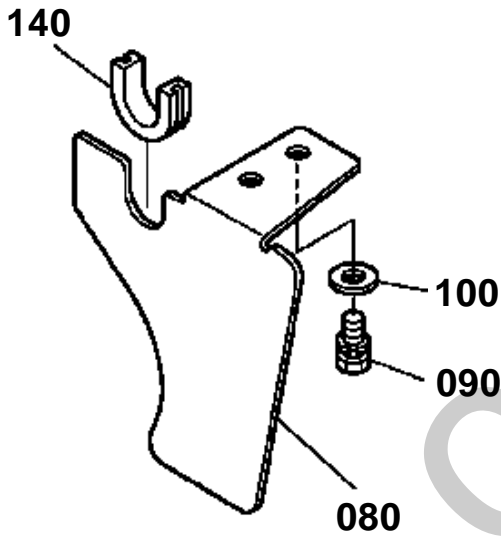

TC220-811-11





## SHUTTER PLATE [EXCEPT HST TYPE]

↔ Interchangeable; ≠ not interchangeable; ← new for old; → old for new

REF.No	Part No.	Description	Q'ty	S.No.	I/C	REMARKS	Weight (kgf)	Weight (lb)
010	T1030-42222	SHIELD	1				0.185	0.407
020	34070-71390	NUT CUSHION	2				0.005	0.011
030	01754-50620	BOLT FLANGE	2				0.007	0.0154
040	TC220-41242	SUPPORT SHUTTER	1				0.36	0.792
050	01754-50825	BOLT FLANGE	2				0.01	0.022
060	TC220-42133	SUPPORT BONNET REAR	1				5.5	12.1
070	T1150-45610	BOLT	4				0.02	0.044
080	TC220-42152	PLATE	1	<=52580			1.1	2.42
080	TC220-42153	PLATE	1	>=52581	-		1.1	2.42
090	01123-60816	BOLT	2	<=51027			0.01	0.022
090	01754-50816	BOLT FLANGE	2	>=51028	-		0.011	0.0242
100	04013-60080	WASHER PLAIN	2	<=51027			0.002	0.0044
110	30430-82770	CUSHION	1				0.005	0.011
120	TC220-42113	PLATE SHUTTER	1				2.3	5.06
130	01754-50816	BOLT FLANGE	3				0.011	0.0242
140	30430-82770	CUSHION	1	<=52580			0.005	0.011
150	31351-35183	CUSHION TANK	1				0.04	0.088
160	TC220-42230	SHIELD SHUTTER LH	1	>=52581			0	0
170	T2050-41490	FASTENER	3	>=52581			0.001	0.0022
180	TC220-42200	SPONGE UPPER	1	>=52581			0.015	0.033
190	TC220-42210	SPONGE LOWER	1	>=52581			0	0

SHUTTER PLATE [HST TYPE]

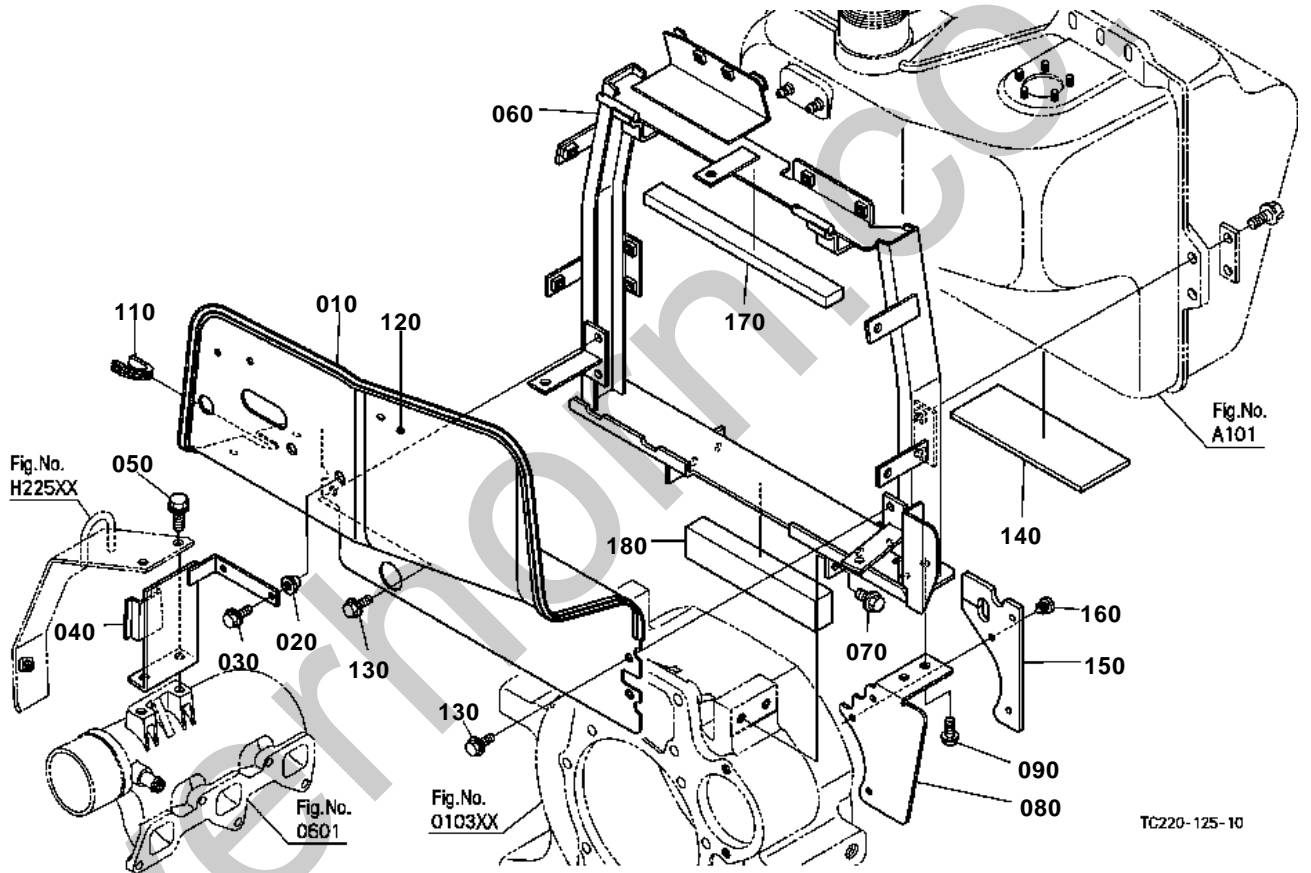

TC220-125-10



## SHUTTER PLATE [HST TYPE]

↔ Interchangeable; ≠ not interchangeable; ← new for old; → old for new

REF.No	Part No.	Description	Q'ty	S.No.	I/C	REMARKS	Weight (kgf)	Weight (lb)
010	T1030-42222	SHIELD	1				0.185	0.407
020	34070-71390	NUT CUSHION	2				0.005	0.011
030	01754-50620	BOLT FLANGE	2				0.007	0.0154
040	TC220-41242	SUPPORT SHUTTER	1				0.36	0.792
050	01754-50825	BOLT FLANGE	2				0.01	0.022
060	TC220-42133	SUPPORT BONNET REAR	1				5.5	12.1
070	T1150-45610	BOLT	4				0.02	0.044
080	TC220-57152	PLATE	1				0	0
090	01754-50816	BOLT FLANGE	2				0.011	0.0242
100	99999-99999	BLANK	0				0	0
110	30430-82770	CUSHION	1				0.005	0.011
120	TC220-42113	PLATE SHUTTER	1				2.3	5.06
130	01754-50816	BOLT FLANGE	3				0.011	0.0242
140	31351-35183	CUSHION TANK	1				0.04	0.088
150	TC220-42230	SHIELD SHUTTER LH	1				0	0
160	T2050-41490	FASTENER	3				0.001	0.0022
170	TC220-42200	SPONGE UPPER	1				0.015	0.033
180	TC220-42210	SPONGE LOWER	1				0	0

HOOD(BONNET) REAR

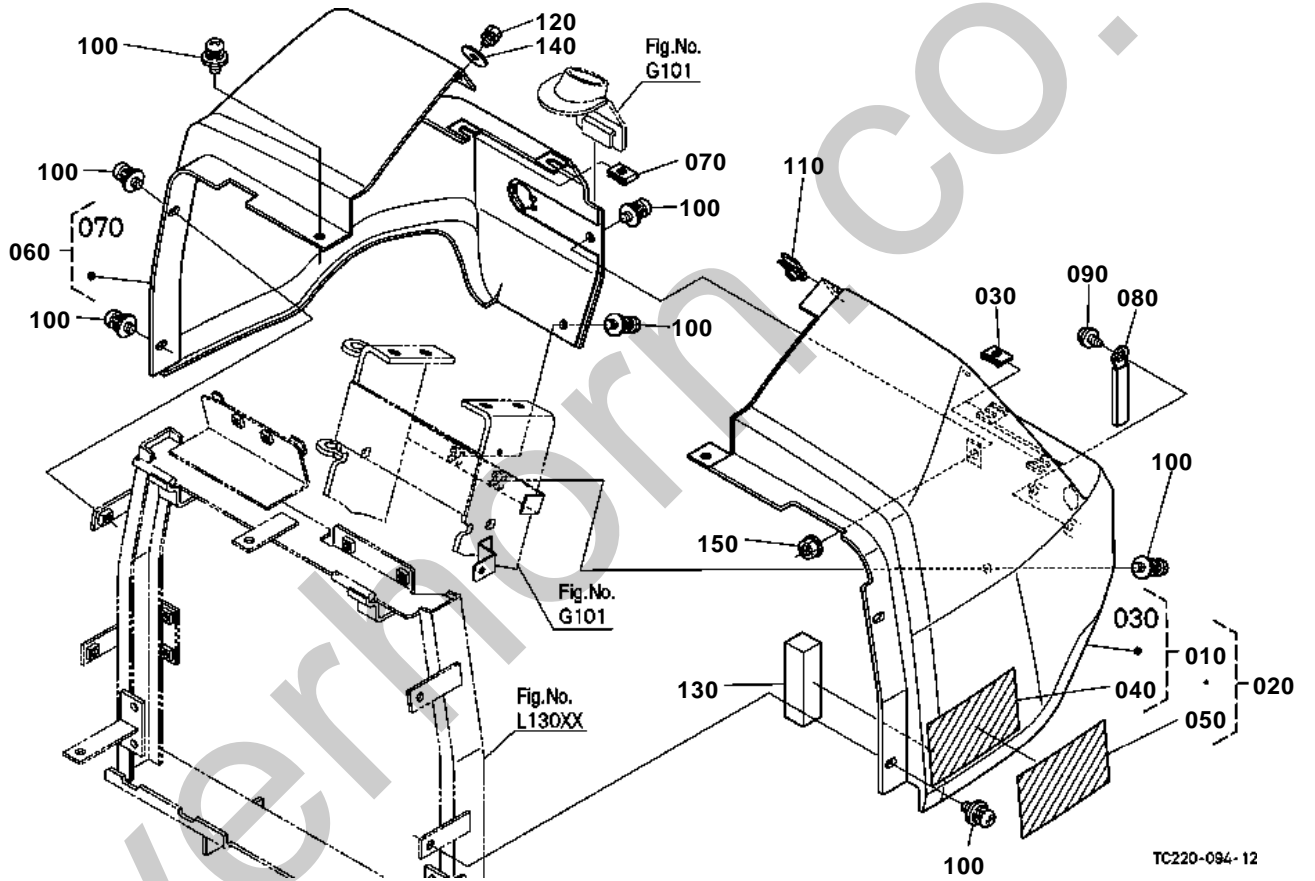

## OLD PARTS

S.No.; A:<=10485, B:<=52262  
, C:<=10330, D:<=53660

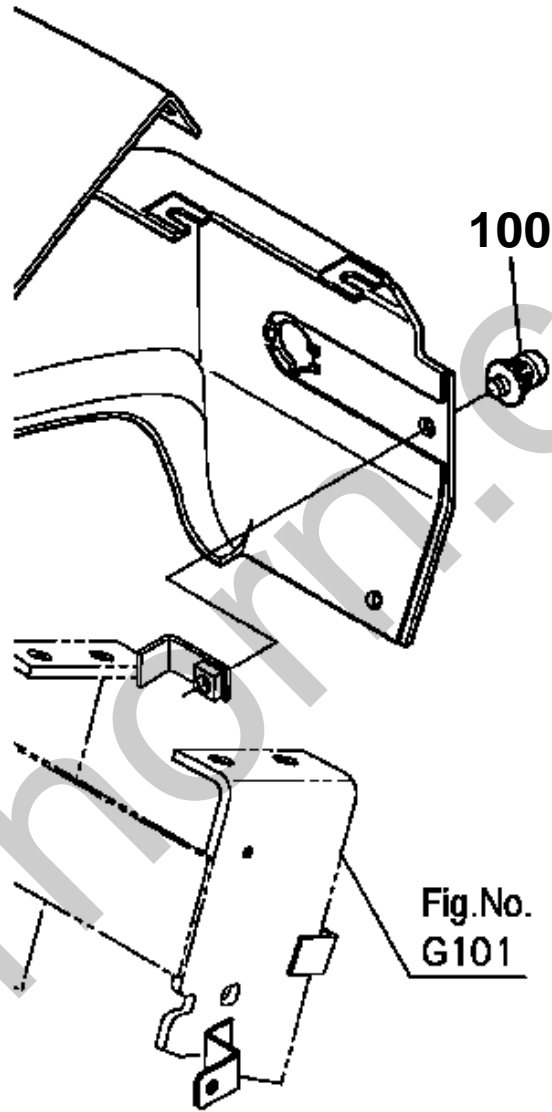

TC220-846-10



# HOOD(BONNET) REAR

↔ Interchangeable; ≠ not interchangeable; ← new for old; → old for new

REF.No	Part No.	Description	Q'ty	S.No.	I/C	REMARKS	Weight (kgf)	Weight (lb)
010	TC220-18920	KIT BONNET REAR(A)	1			ENGLISH	0.75	1.65
020	TC220-18930	KIT BONNET REAR(B)	1			FRENCH	0.75	1.65
030	3A011-83490	NUT SPRING	3				0.01	0.022
040	TA040-49650	LABEL START CAUTION	1			ENGLISH	0.004	0.0088
050	TA041-49650	LABEL START CAUTION	1			FRENCH	0.004	0.0088
060	TC220-18790	ASSY BONNET REAR RH	1				0.78	1.716
070	3A011-83490	NUT SPRING	3				0.01	0.022
080	15272-67590	CLAMP CORD	2				0.004	0.0088
090	03614-50610	SCREW TAPPING	2				0.005	0.011
100	03034-50816	SCREW WITH WASHER	8				0.01	0.022
110	34070-99160	NUT SPRING	1				0.005	0.011
120	01023-50612	BOLT	1				0.005	0.011
130	TC220-18840	SPONGE BONNET REAR	1				0.01	0.022
140	04015-60080	WASHER PLAIN	1				0.01	0.022
150	02751-50080	NUT FLANGE	1	>=52263			0.006	0.0132

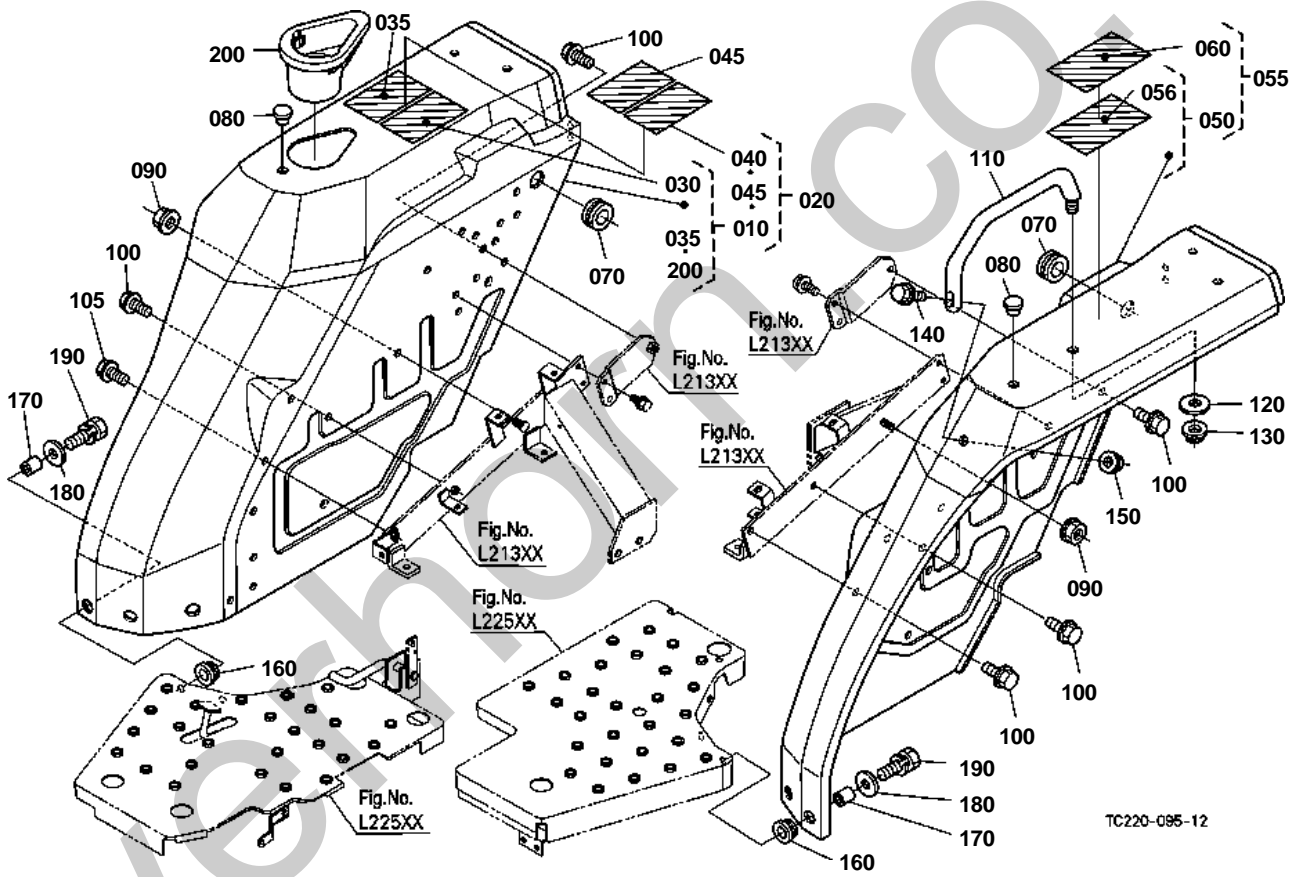

TC220-085-12

# OLD PARTS

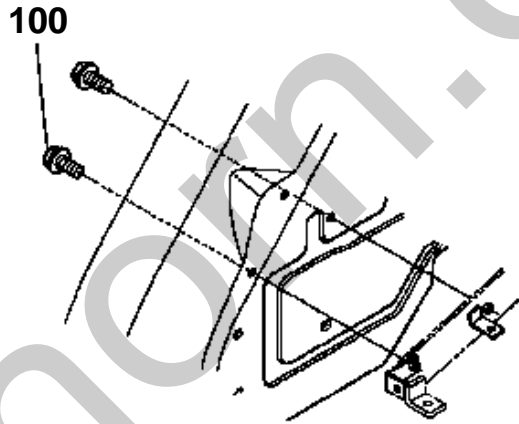
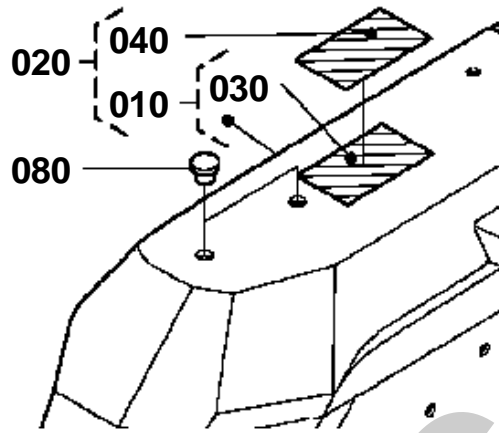

TC220-837-11



**FENDER**

↔ Interchangeable; ≠ not interchangeable; ← new for old; → old for new

REF.No	Part No.	Description	Q'ty	S.No.	I/C	REMARKS	Weight (kgf)	Weight (lb)
010	TC220-47102	KIT FENDER RH(A)	1	<=52262		ENGLISH NOT SALE	8.4	18.48
010	TC220-47103	KIT FENDER RH(A)	1	>=52263	-	ENGLISH	8.4	18.48
020	TC220-47112	KIT FENDER RH(B)	1	<=52262		FRENCH NOT SALE	8.4	18.48
020	TC220-47113	KIT FENDER RH(B)	1	>=52263	-	FRENCH	8.4	18.48
030	TA240-98480	LABEL ROPS WARNING	1			ENGLISH FOLDABLE ROPS TYPE	0.005	0.011
030	TA040-49320	LABEL ROPS WARNING	1			ENGLISH RIGID ROPS TYPE	0.001	0.0022
035	TA140-49330	LABEL SHUTTLE	1	>=52263		ENGLISH EXCEPT HST TYPE	0.005	0.011
035	TA240-49330	LABEL PARKING WARNI.	1	>=52263		ENGLISH HST TYPE	0.005	0.011
040	3A112-98480	LABEL ROPS WARNING	1			FRENCH FOLDABLE ROPS TYPE	0.004	0.0088
040	TA040-49150	LABEL ROPS WARNING	1			FRENCH RIGID ROPS TYPE	0.003	0.0066
045	TA141-49330	LABEL SHUTTLE	1	>=52263		FRENCH EXCEPT HST TYPE	0.005	0.011
045	TA241-49330	LABEL PARKING WARNI.	1	>=52263		FRENCH HST TYPE	0.005	0.011
050	TC220-99530	KIT FENDER LH(A)	1			ENGLISH	8.3	18.26
055	TC220-99540	KIT FENDER LH(B)	1			FRENCH	0	0
056	35260-34914	LABEL SAFETY	1			ENGLISH	0.005	0.011
060	TA041-65702	LABEL SAFETY	1			FRENCH	0.01	0.022
070	53761-61260	GROMMET CIRCLE	2				0.005	0.011
080	30810-29170	PLUG	3	<=52262			0.003	0.0066
080	30810-29170	PLUG	2	>=52263			0.003	0.0066
090	02751-50080	NUT FLANGE	2				0.006	0.0132
100	01754-50816	BOLT FLANGE	6	<=53881			0.011	0.0242
100	01754-50816	BOLT FLANGE	5	>=53882			0.011	0.0242
105	01754-50820	BOLT FLANGE	1	>=53882			0.015	0.033
110	T0270-29442	GRIP	1				0.3	0.66
120	04013-60100	WASHER PLAIN	1				0.003	0.0066
130	02771-60100	NUT FLANGE	1				0.01	0.022
140	T0180-83590	BOLT FLANGE	1				0.022	0.0484
150	02771-60100	NUT FLANGE	1				0.01	0.022
160	3A111-87360	CUSHION	6				0.005	0.011
170	TC030-29130	COLLAR	6				0.005	0.011
180	3A211-53500	WASHER PLAIN	6				0.011	0.0242
190	01123-50830	BOLT	6				0.015	0.033
200	TC220-47290	HOLDER CUP	1	>=52263			0	0
200	TC220-47292	HOLDER CUP	1	>=52428	-		0.12	0.264

FENDER SUPPORT [EXCEPT HST TYPE]

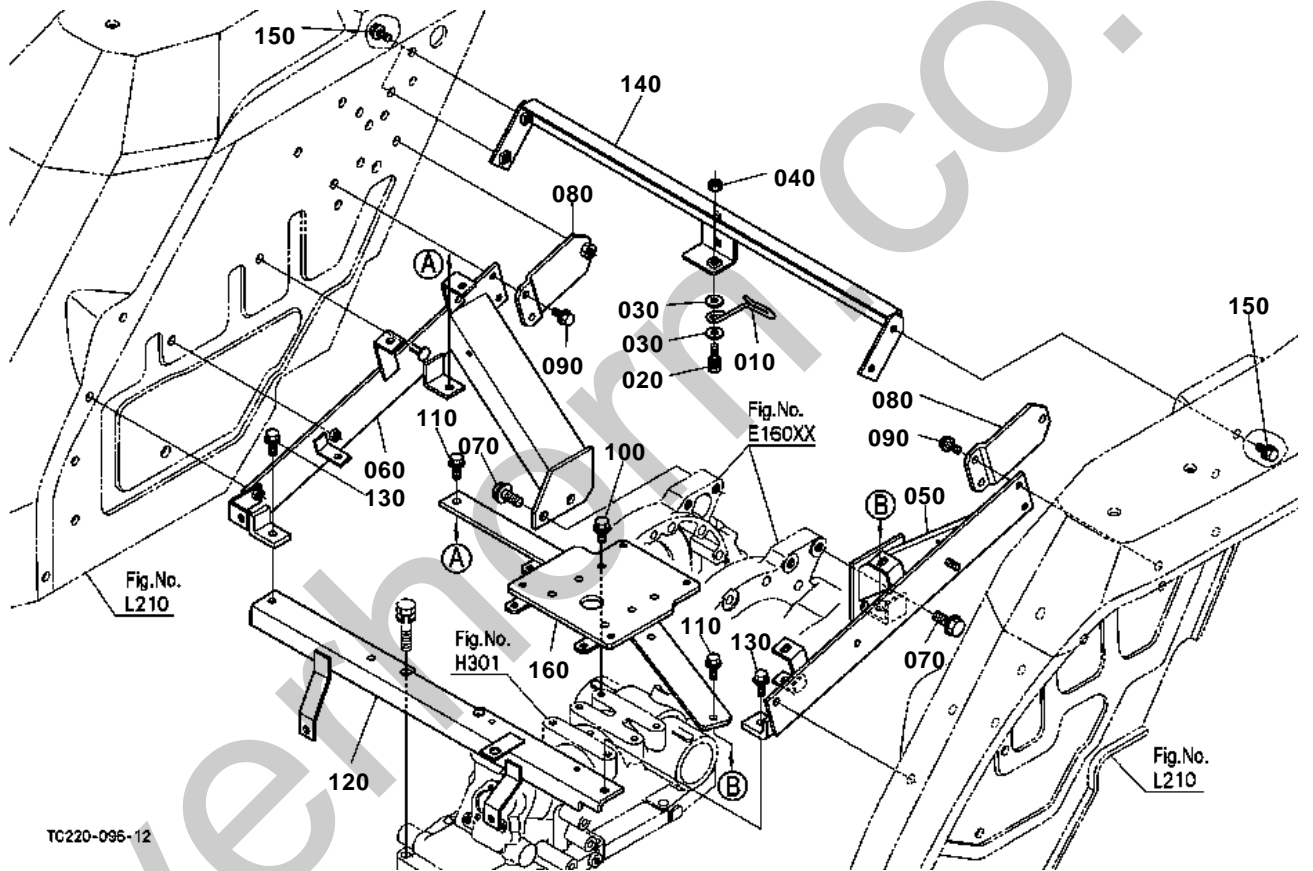

TC220-095-12

## OLD PARTS

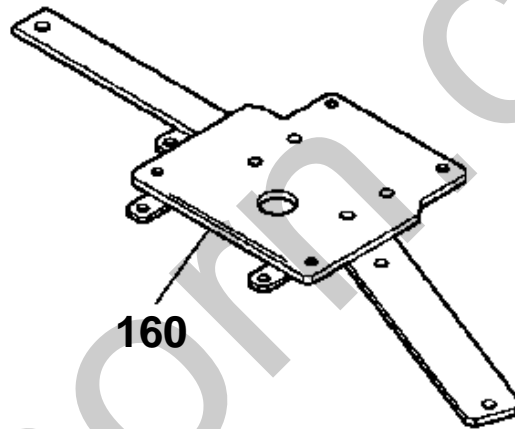
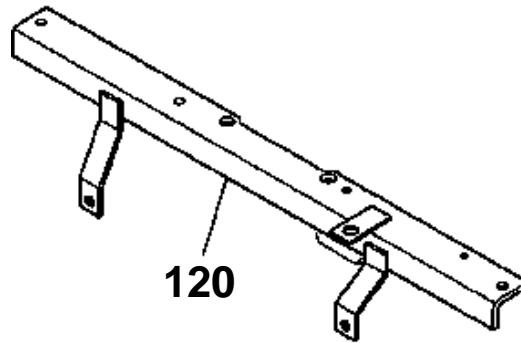

TC220-838-11



## FENDER SUPPORT [EXCEPT HST TYPE]

↔ Interchangeable; ≠ not interchangeable; ← new for old; → old for new

REF.No	Part No.	Description	Q'ty	S.No.	I/C	REMARKS	Weight (kgf)	Weight (lb)
010	TC220-29420	HOLDER	1				0.04	0.088
020	01123-50830	BOLT	1				0.015	0.033
030	04015-60080	WASHER PLAIN	2				0.01	0.022
040	02112-50080	NUT	1				0.003	0.0066
050	TC220-29210	SUPPORT FENDER LH	1				3	6.6
060	TC220-29220	SUPPORT FENDER RH	1	<=55198			3	6.6
060	TC220-29222	SUPPORT FENDER RH	1	>=55199	-		3	6.6
070	01774-51220	BOLT FLANGE	4				0.03	0.066
080	TC220-29250	SUPPORT FENDER	2				0.37	0.814
080	TC220-29252	SUPPORT FENDER	2		<<		0.37	0.814
090	01754-50812	BOLT FLANGE	4				0.01	0.022
100	01774-61020	BOLT FLANGE	4				0.022	0.0484
110	01754-50825	BOLT FLANGE	2				0.01	0.022
120	TC220-29240	STAY FENDER	1	<=57222			2	4.4
120	TC220-29242	STAY FENDER	1	>=57223	-		2	4.4
130	01754-50825	BOLT FLANGE	2				0.01	0.022
140	TC220-29440	SUPPORT FENDER	1				1.35	2.97
150	01754-50816	BOLT FLANGE	4				0.011	0.0242
160	TC220-29233	SUPPORT SEAT	1	<=53276			2.3	5.06
160	TC220-29234	SUPPORT SEAT	1	>=53277	-		2.3	5.06

FENDER SUPPORT [HST TYPE]

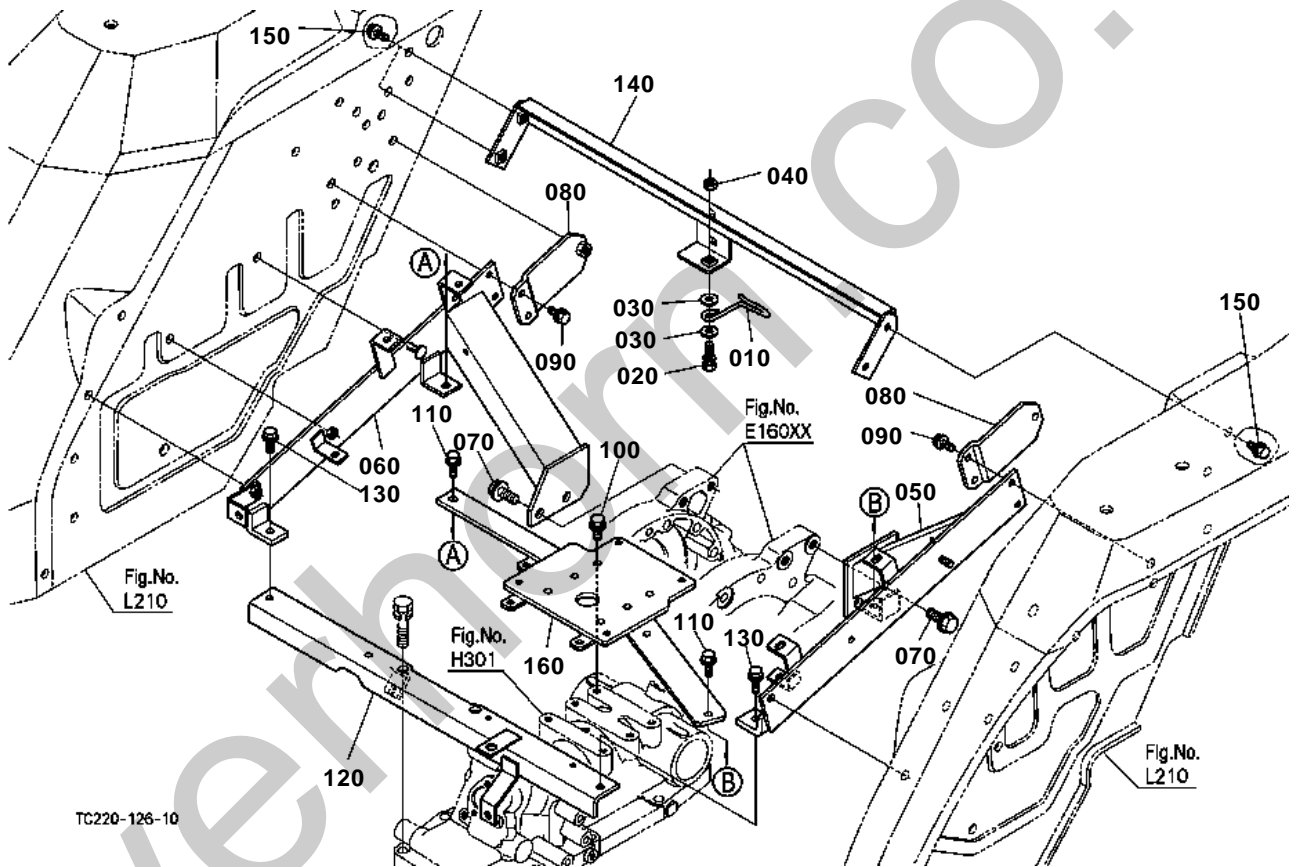

TC220-126-10



# FENDER SUPPORT [HST TYPE]

↔ Interchangeable; ≠ not interchangeable; ← new for old; → old for new

REF.No	Part No.	Description	Q'ty	S.No.	I/C	REMARKS	Weight (kgf)	Weight (lb)
010	TC220-29420	HOLDER	1				0.04	0.088
020	01123-50830	BOLT	1				0.015	0.033
030	04015-60080	WASHER PLAIN	2				0.01	0.022
040	02112-50080	NUT	1				0.003	0.0066
050	TC220-29210	SUPPORT FENDER LH	1				3	6.6
060	TC220-29220	SUPPORT FENDER RH	1	<=55198			3	6.6
060	TC220-29222	SUPPORT FENDER RH	1	>=55199	-		3	6.6
070	01774-51220	BOLT FLANGE	4				0.03	0.066
080	TC220-29252	SUPPORT FENDER	2				0.37	0.814
090	01754-50812	BOLT FLANGE	4				0.01	0.022
100	01774-61020	BOLT FLANGE	4				0.022	0.0484
110	01754-50825	BOLT FLANGE	2				0.01	0.022
120	TC220-57722	STAY FENDER	1				0	0
130	01754-50825	BOLT FLANGE	2				0.01	0.022
140	TC220-29440	SUPPORT FENDER	1				1.35	2.97
150	01754-50816	BOLT FLANGE	4				0.011	0.0242
160	TC220-29234	SUPPORT SEAT	1				2.3	5.06

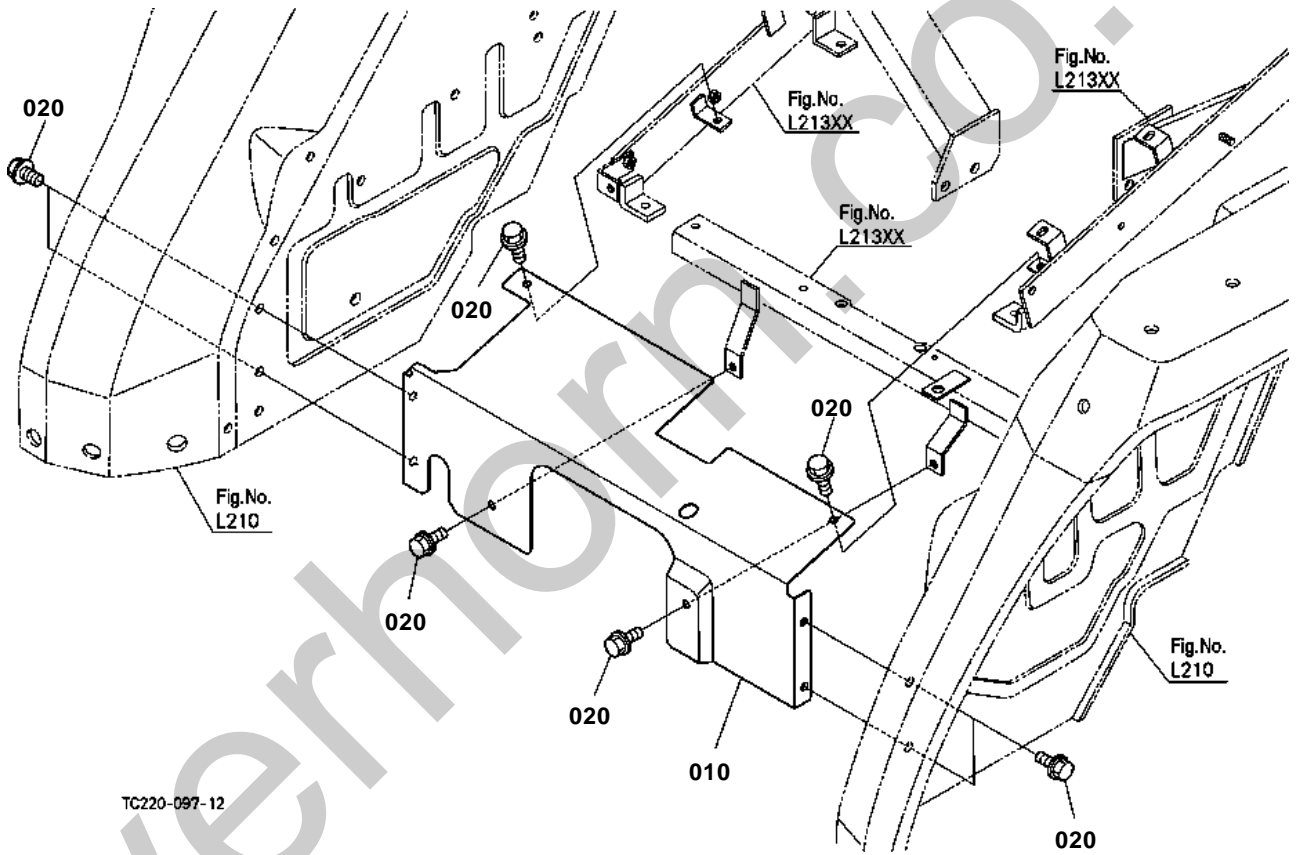

TC220-097-12



## FLOOR SEAT COVER [EXCEPT HST TYPE]

↔ Interchangeable; ≠ not interchangeable; ← new for old; → old for new

REF.No	Part No.	Description	Q'ty	S.No.	I/C	REMARKS	Weight (kgf)	Weight (lb)
010	TC220-47210	COVER FLOOR SEAT	1				2.1	4.62
020	01754-50816	BOLT FLANGE	8				0.011	0.0242



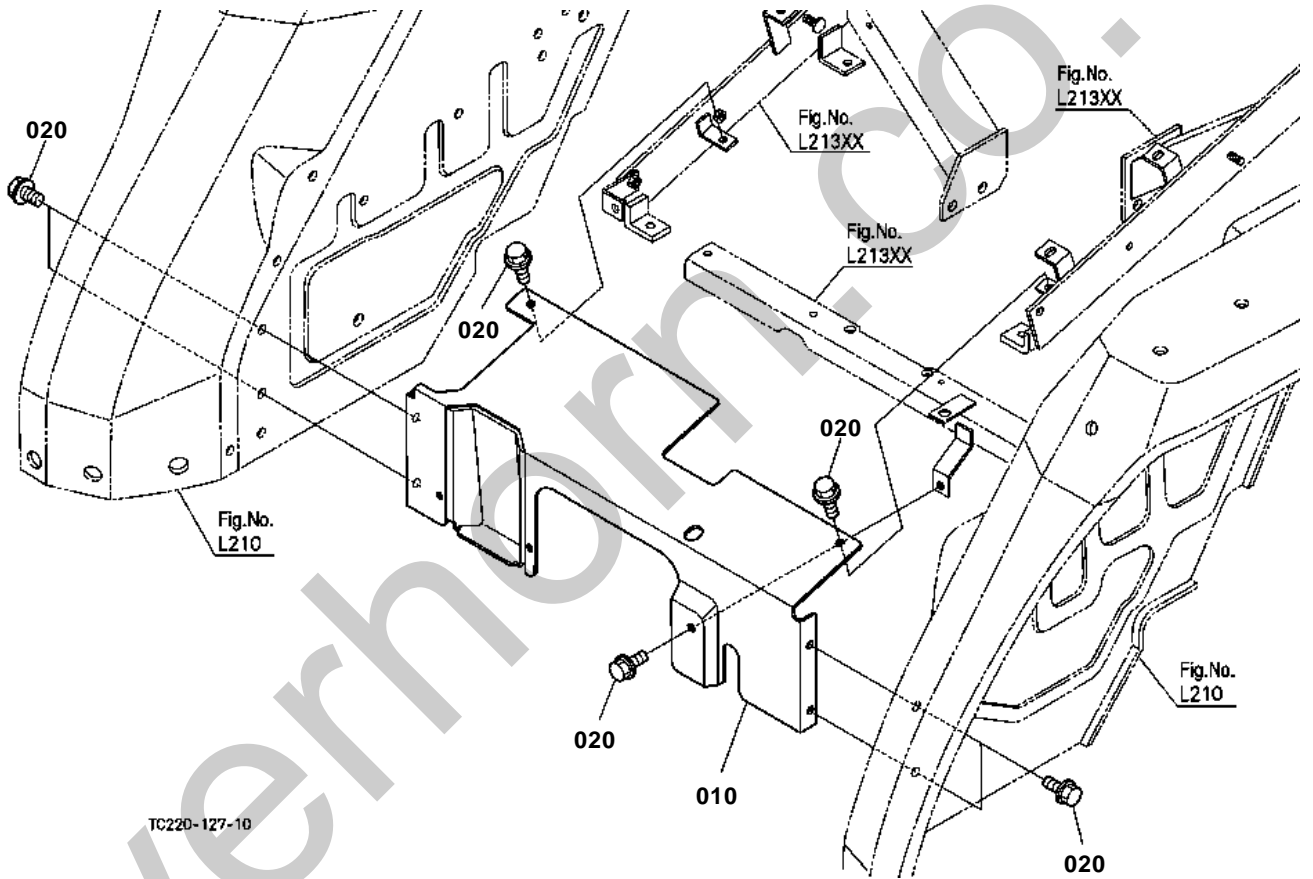

TC220-127-10



# FLOOR SEAT COVER [HST TYPE]

↔ Interchangeable; ≠ not interchangeable; ← new for old; → old for new

REF.No	Part No.	Description	Q'ty	S.No.	I/C	REMARKS	Weight (kgf)	Weight (lb)
010	TC220-57540	COVER FLOOR SEAT	1				0	0
020	01754-50816	BOLT FLANGE	7				0.011	0.0242

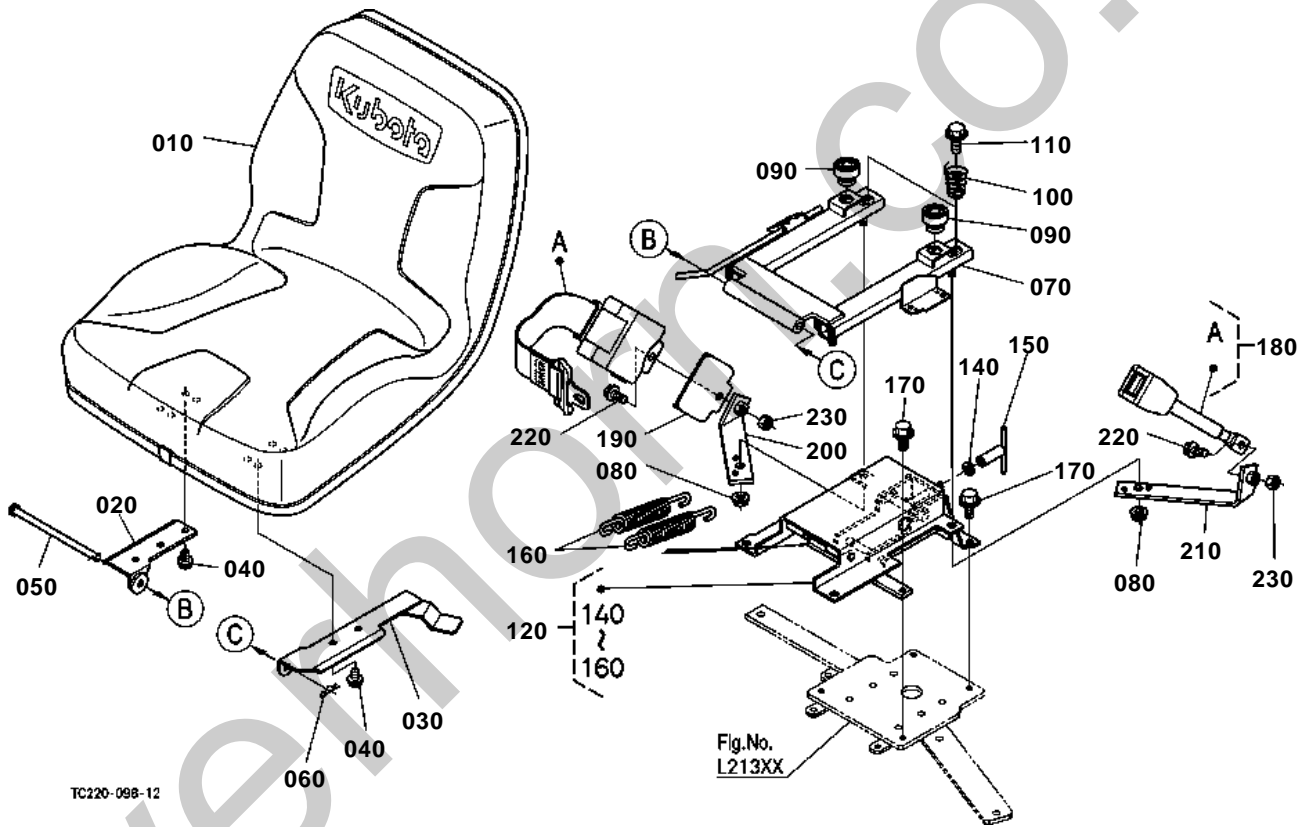

OLD PARTS



210

Silverhorn.CO.UK

TC220-826-10



## SEAT

↔ Interchangeable; ≠ not interchangeable; ← new for old; → old for new

REF.No	Part No.	Description	Q'ty	S.No.	I/C	REMARKS	Weight (kgf)	Weight (lb)
010	TC220-88720	SEAT	1				7.4	16.28
020	TC050-18450	BRACKET SEAT RH	1				0.2	0.44
030	TC220-18460	BRACKET SEAT LH	1	<=52900			0.45	0.99
030	TC220-18462	BRACKET SEAT LH	1	>=52901	-		0.45	0.99
040	01754-50816	BOLT FLANGE	4				0.011	0.0242
050	TC050-11850	PIN	1				0.1	0.22
060	05516-61000	PIN SNAP	1				0.003	0.0066
070	3A272-18430	ASSY ADJUSTER SEAT	1				2.5	5.5
080	02783-50100	NUT FLANGE	4				0.01	0.022
090	32160-18440	CUSHION	2				0.013	0.0286
100	3A272-75270	SPRING SEAT	2				0.03	0.066
110	01754-50816	BOLT FLANGE	2				0.011	0.0242
120	TC220-11802	ASSY SUSPENSION SEAT	1				3.9	8.58
130	99999-99999	BLANK	0				0	0
140	04011-50100	WASHER PLAIN	1				0.002	0.0044
150	TA040-11860	NUT ADJUSTING	1				0.605	1.331
160	TA040-11870	SPRING SEAT	2				0.26	0.572
170	01754-50816	BOLT FLANGE	4				0.011	0.0242
180	TD060-47780	ASSY BELT SEAT	1				0.805	1.771
190	TC050-18472	COVER BELT SEAT	1				0.09	0.198
200	TA040-18482	BRACKET SEAT BELT RH	1				0.27	0.594
210	TC030-18490	BRACKET SEAT BELT LH	1	<=52427			0.3	0.66
210	TC030-18492	BRACKET SEAT BELT LH	1	>=52428	-		0.3	0.66
220	01774-51025	BOLT FLANGE	2				0.02	0.044
230	02116-50100	NUT	2				0.004	0.0088

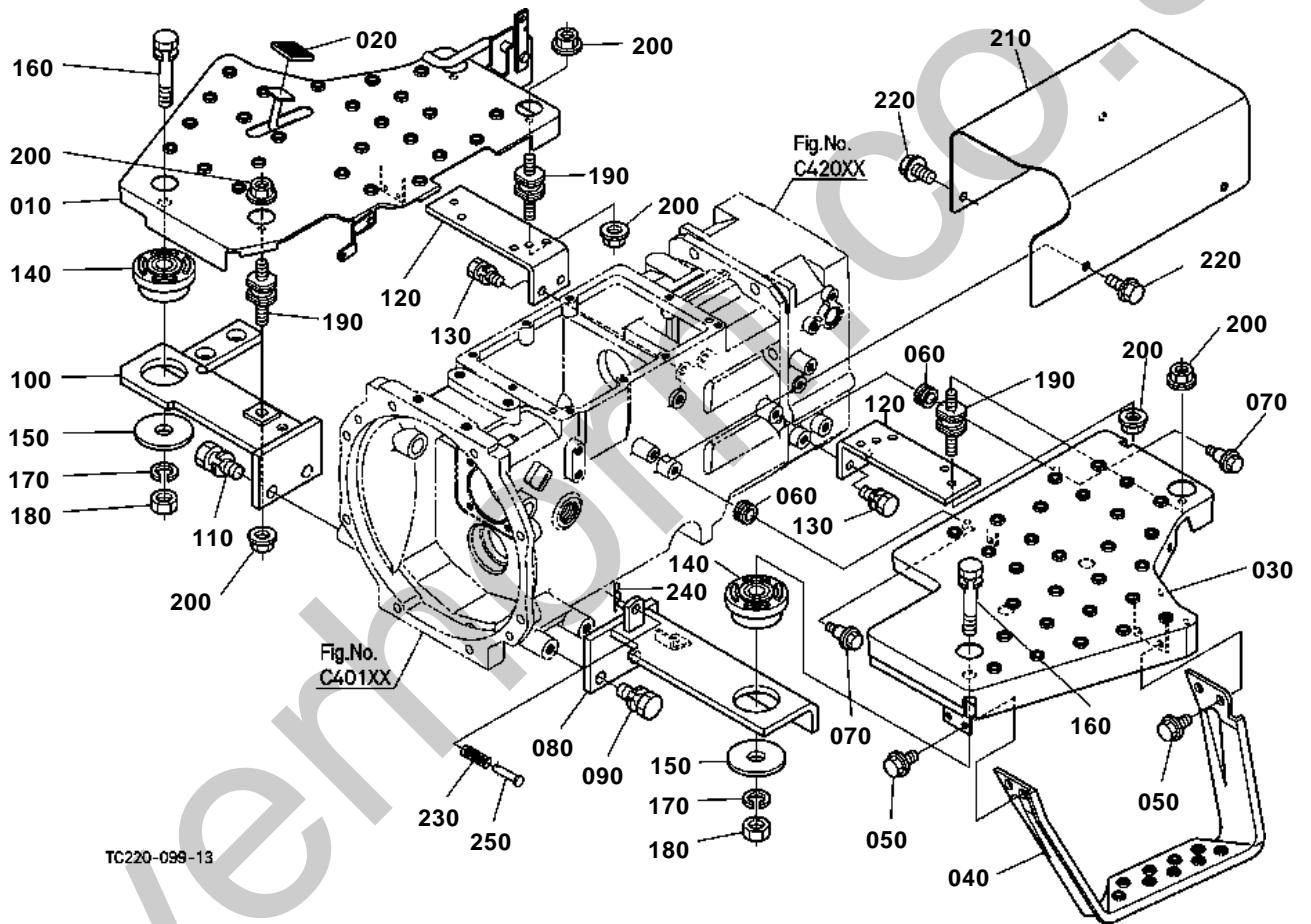

TC220-099-13

# OLD PARTS

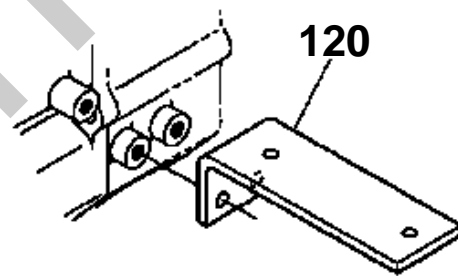
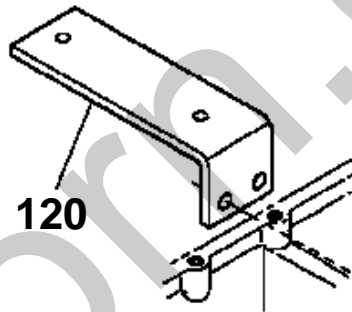
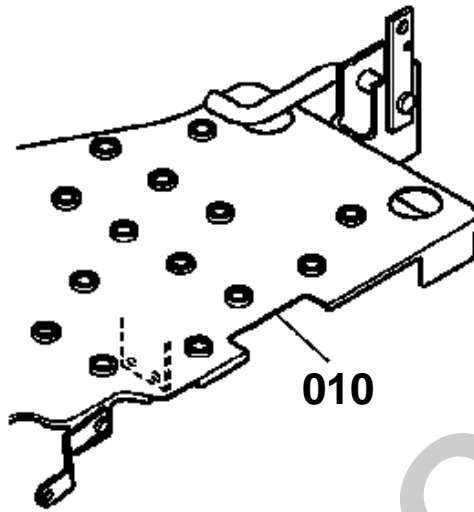

TC220-843-11



## STEP [EXCEPT HST TYPE]

↔ Interchangeable; ≠ not interchangeable; ← new for old; → old for new

REF.No	Part No.	Description	Q'ty	S.No.	I/C	REMARKS	Weight (kgf)	Weight (lb)
010	TC220-29902	COMP.STEP RH	1	<=53276			0	0
010	TC220-29903	COMP.STEP RH	1	>=53277	-		0	0
010	TC220-29904	COMP.STEP RH	1	>=54356	-		5.6	12.32
020	37410-44850	COVER ACCEL.PEDAL	1				0.01	0.022
030	TC220-29920	STEP LH	1	<=53276			0	0
030	TC220-29922	STEP LH	1	>=53277	-		5.3	11.66
040	TA140-47470	STEP AID LH	1	<=57744			0.985	2.167
040	TA140-47472	STEP AID LH	1	>=57745	-		0.985	2.167
050	01754-50812	BOLT FLANGE	4				0.01	0.022
060	6A100-51380	CUSHION	2				0.003	0.0066
070	TC220-29160	BOLT	2				0.02	0.044
080	TC220-29140	BRACKET STEP FRON.LH	1	<=52580			0	0
080	TC220-29143	BRACKET STEP FRON.LH	1	>=52581	-		2.3	5.06
090	01133-51230	BOLT	2				0.04	0.088
100	TC220-29150	BRACKET STEP FRON.RH	1	<=52580			2	4.4
100	TC220-29153	BRACKET STEP FRON.RH	1	>=52581	-		2	4.4
110	01133-51230	BOLT	2				0.04	0.088
120	TC220-47410	BRACKET STEP REAR	2	<=57222			1.03	2.266
120	TC220-47412	BRACKET STEP REAR	2	>=57223	-		1.03	2.266
130	01133-51025	BOLT	4				0.023	0.0506
140	T2050-47380	CUSHION	2				0.162	0.3564
150	34070-47320	WASHER	2				0.1	0.22
160	01133-61660	BOLT	2				0.12	0.264
170	04512-60160	WASHER SPRING	2				0.01	0.022
180	02174-50160	NUT	2				0.022	0.0484
190	TC030-47350	CUSHION	4				0.038	0.0836
200	02751-50080	NUT FLANGE	8				0.006	0.0132
210	TC220-29930	COVER CENTER	1				2	4.4
220	01754-50812	BOLT FLANGE	4				0.01	0.022
230	TC220-15950	SPRING	1				0.002	0.0044
240	05515-60800	PIN SNAP	1	<=51997			0.002	0.0044
240	52300-34120	PIN SNAP	1	>=51998	-		0.001	0.0022
250	05122-50840	PIN JOINT	1				0.017	0.0374





## OLD PARTS

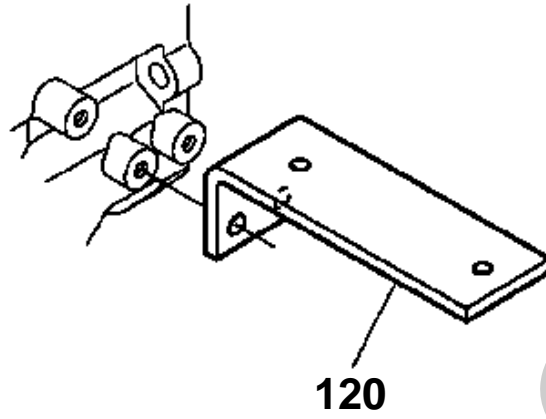

Silverhorn.CO.UK

TC220-849-10



## STEP [HST TYPE]

↔ Interchangeable; ≠ not interchangeable; ← new for old; → old for new

REF.No	Part No.	Description	Q'ty	S.No.	I/C	REMARKS	Weight (kgf)	Weight (lb)
010	TC220-57480	COMP.STEP RH	1				0	0
020	99999-99999	BLANK	0				0	0
030	TC220-57470	COMP.STEP LH	1				0	0
040	TA140-47470	STEP AID LH	1	<=57744			0.985	2.167
040	TA140-47472	STEP AID LH	1	>=57745	→		0.985	2.167
050	01754-50812	BOLT FLANGE	4				0.01	0.022
060	6A100-51380	CUSHION	2				0.003	0.0066
070	TC220-29160	BOLT	2				0.02	0.044
080	TC220-57412	BRACKET STEP FRON.LH	1				0	0
090	01133-51230	BOLT	2				0.04	0.088
100	TC220-29153	BRACKET STEP FRON.RH	1				2	4.4
110	01133-51230	BOLT	2				0.04	0.088
120	TC220-47410	BRACKET STEP REAR	1	<=57222			1.03	2.266
120	TC220-47412	BRACKET STEP REAR	1	>=57223	→		1.03	2.266
125	TC220-57440	BRACKET STEP REAR RH	1				0	0
130	01133-51025	BOLT	4				0.023	0.0506
140	T2050-47380	CUSHION	2				0.162	0.3564
150	34070-47320	WASHER	2				0.1	0.22
160	01133-61660	BOLT	2				0.12	0.264
170	04512-60160	WASHER SPRING	2				0.01	0.022
180	02174-50160	NUT	2				0.022	0.0484
190	TC030-47350	CUSHION	4				0.038	0.0836
200	02751-50080	NUT FLANGE	8				0.006	0.0132
210	TC220-57530	COVER CENTER	1				0	0
220	01754-50812	BOLT FLANGE	4				0.01	0.022
230	TC220-15950	SPRING	1				0.002	0.0044
240	52300-34120	PIN SNAP	1				0.001	0.0022
250	05122-50840	PIN JOINT	1				0.017	0.0374

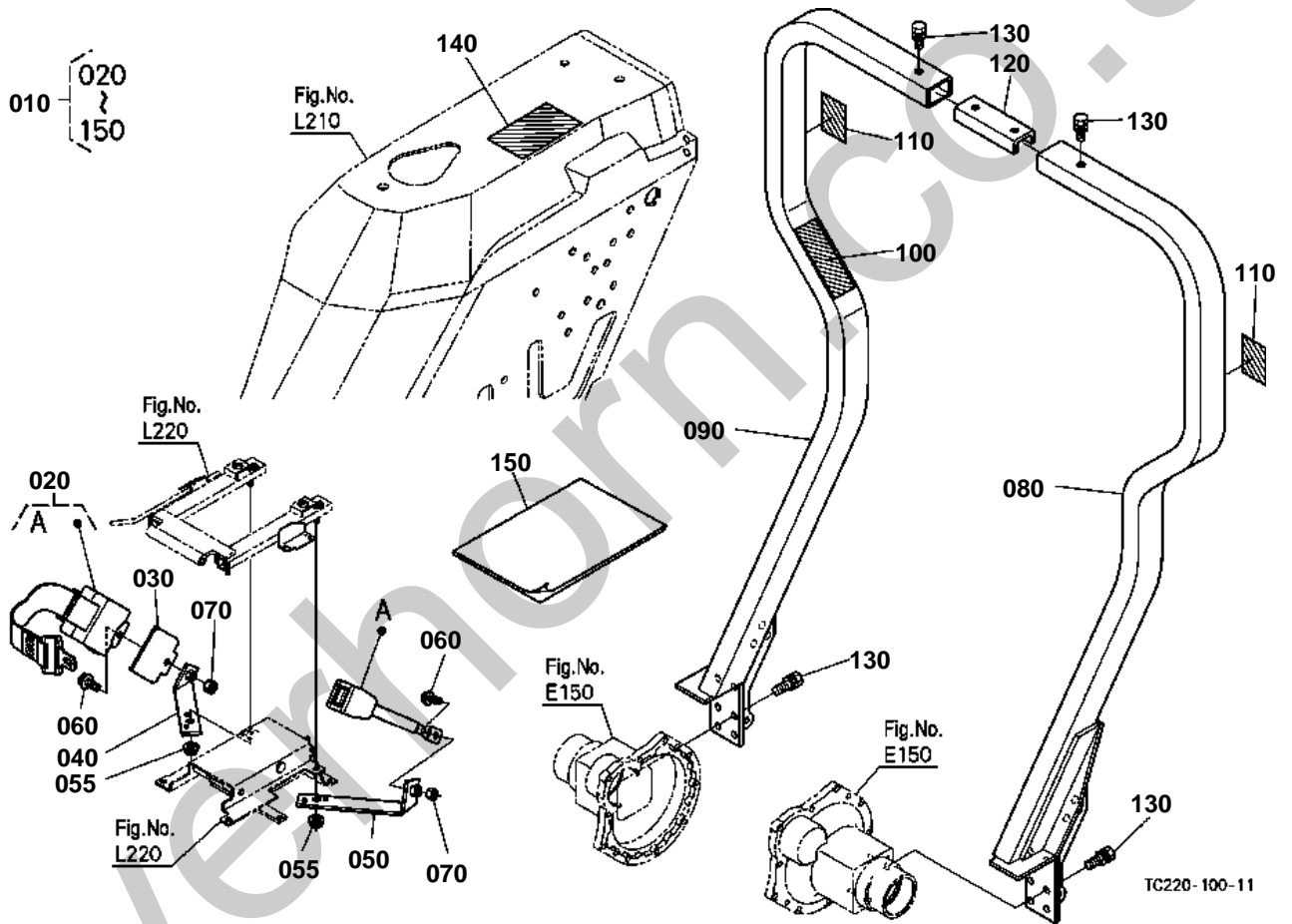

# OLD PARTS



Silverhorn.CO.UK

TC220-827-10

**ROPS (RIGID TYPE)**

↔ Interchangeable; ≠ not interchangeable; ← new for old; → old for new

REF.No	Part No.	Description	Q'ty	S.No.	I/C	REMARKS	Weight (kgf)	Weight (lb)
010	TC220-70080	KIT ROPS REPLACEMENT	1			NOT SALE	0	0
020	TD060-47780	ASSY BELT SEAT	1				0.805	1.771
030	TC050-18472	COVER BELT SEAT	1				0.09	0.198
040	TA040-18482	BRACKET SEAT BELT RH	1				0.27	0.594
050	TC030-18490	BRACKET SEAT BELT LH	1	<=52427			0.3	0.66
050	TC030-18492	BRACKET SEAT BELT LH	1	>=52428	-		0.3	0.66
055	02783-50100	NUT FLANGE	2				0.01	0.022
060	01774-51025	BOLT FLANGE	2				0.02	0.044
070	02116-50100	NUT	2				0.004	0.0088
080	99999-99999	FRAME LH	1				0	0
090	99999-99999	FRAME RH	1				0	0
100	6C140-47460	LABEL ROPS WARNING	1			ENGLISH	0.001	0.0022
100	6C141-47460	LABEL ROPS WARNING	1			FRENCH	0.001	0.0022
110	6C140-54990	REFLECTOR LABEL	2				0.003	0.0066
120	99999-99999	CONNECTOR	1				0	0
130	01138-51430	BOLT	10				0.07	0.154
140	TA040-49320	LABEL ROPS WARNING	1			ENGLISH	0.001	0.0022
140	TA040-49150	LABEL ROPS WARNING	1			FRENCH	0.003	0.0066
150	99999-99999	MANUAL ASSEMBLY	1				0	0

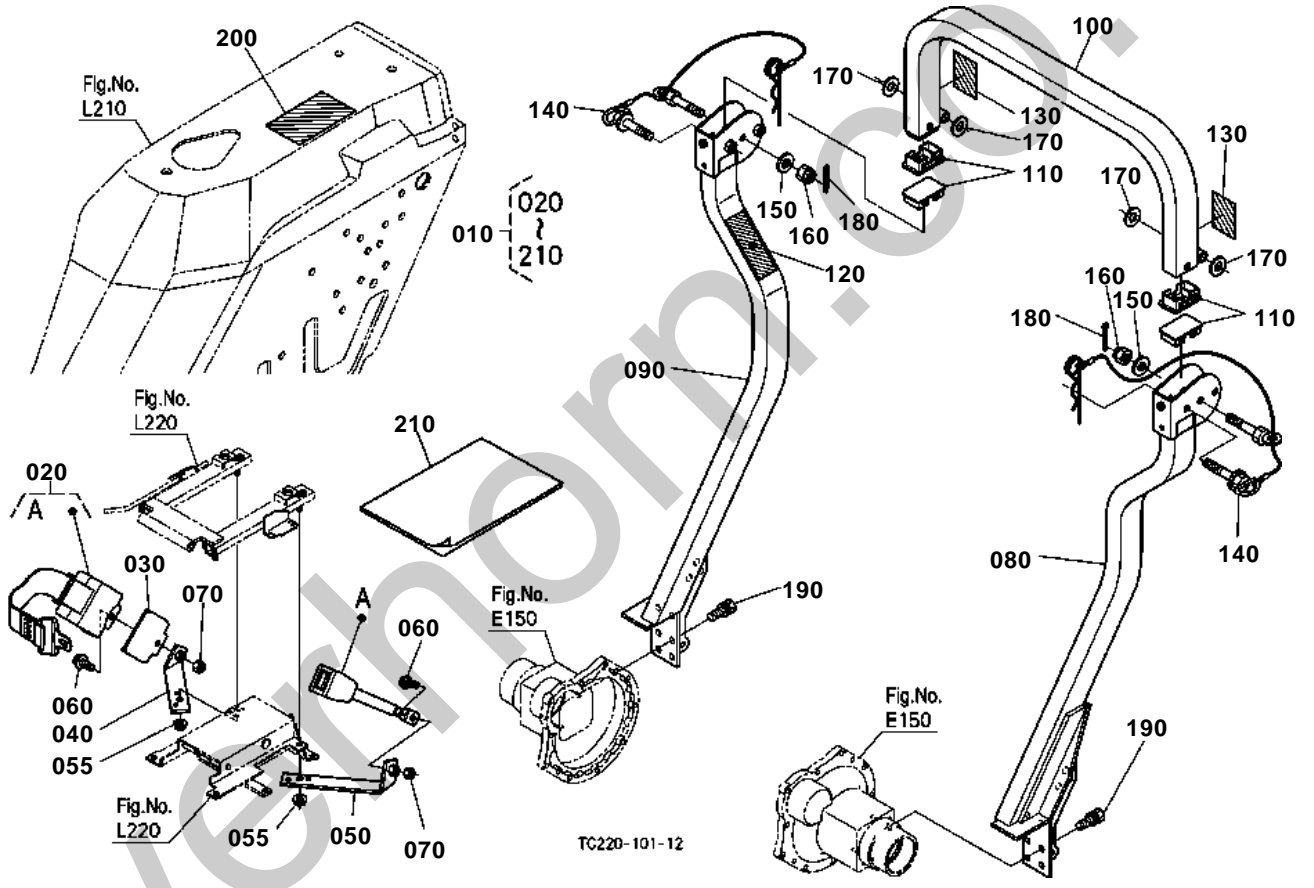

# OLD PARTS



Silverhorn.CO.UK

TC220-827-10





ROPS (FOLDABLE TYPE)

↔ Interchangeable; ≠ not interchangeable; ← new for old; → old for new

REF.No	Part No.	Description	Q'ty	S.No.	I/C	REMARKS	Weight (kgf)	Weight (lb)
010	TC220-70070	KIT ROPS REPLACEMENT	1			NOT SALE	0	0
020	TD060-47780	ASSY BELT SEAT	1				0.805	1.771
030	TC050-18472	COVER BELT SEAT	1				0.09	0.198
040	TA040-18482	BRACKET SEAT BELT RH	1				0.27	0.594
050	TC030-18490	BRACKET SEAT BELT LH	1	<=52427			0.3	0.66
050	TC030-18492	BRACKET SEAT BELT LH	1	>=52428	-		0.3	0.66
055	02783-50100	NUT FLANGE	2				0.01	0.022
060	01774-51025	BOLT FLANGE	2				0.02	0.044
070	02116-50100	NUT	2				0.004	0.0088
080	99999-99999	FRAME LOWER LH	1				0	0
090	99999-99999	FRAME LOWER RH	1				0	0
100	99999-99999	FRAME UPPER	1				0	0
110	TC050-48773	COVER ROPS	4				0.03	0.066
120	3A111-95540	LABEL ROPS CAUTION	1			ENGLISH	0.003	0.0066
120	3A112-95540	LABEL ROPS CAUTION	1			FRENCH	0.003	0.0066
130	6C140-54990	REFLECTOR LABEL	2				0.003	0.0066
140	TA240-48752	SET BOLT	2				0.435	0.957
150	04013-60160	WASHER PLAIN	2				0.01	0.022
160	02254-50160	NUT	2				0.04	0.088
170	04013-60160	WASHER PLAIN	4				0.01	0.022
180	05511-50430	PIN SPLIT	2				0.004	0.0088
190	01138-51430	BOLT	8				0.07	0.154
200	TA240-98480	LABEL ROPS WARNING	1			ENGLISH	0.005	0.011
200	3A112-98480	LABEL ROPS WARNING	1			FRENCH	0.004	0.0088
210	99999-99999	MANUAL ASSEMBLY	1				0	0

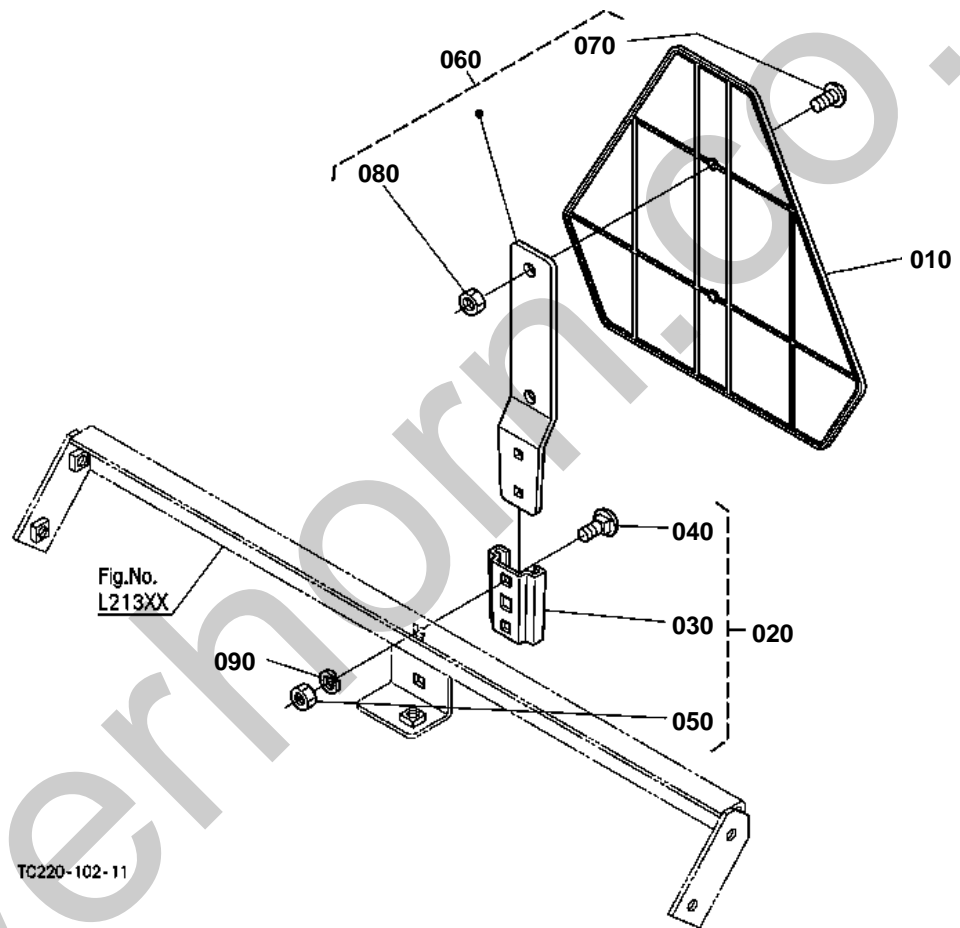

## OLD PARTS

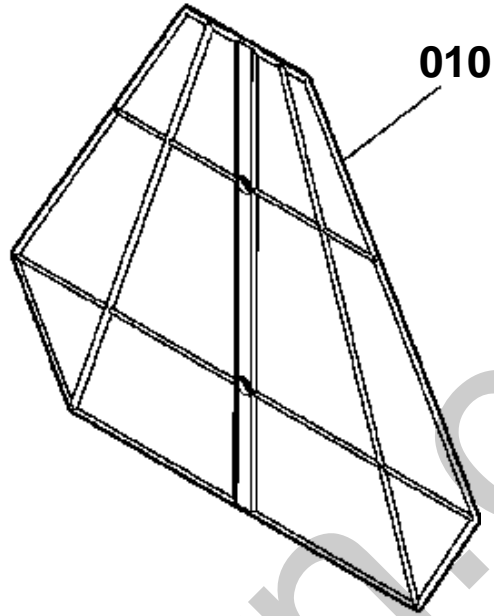

TC220-839-10

**SMV EMBLEM**

↔ Interchangeable; ≠ not interchangeable; ← new for old; → old for new

REF.No	Part No.	Description	Q'ty	S.No.	I/C	REMARKS	Weight (kgf)	Weight (lb)
010	7L500-89910	SIGN SMV	1	<=52580		NOT SALE	0.32	0.704
010	7L500-89912	SIGN SMV	1	>=52581	«		0.32	0.704
020	7L500-89920	SOCKET SMV SIGN	1				0.1	0.22
030	7L500-89930	SOCKET-MTG SMV	1				0.05	0.11
040	7L500-89940	BOLT SQUARE NECK	2				0.01	0.022
050	7L500-89950	NUT	2				0.004	0.0088
060	7L500-89960	SPADE SMV SIGN	1				0.24	0.528
070	7L500-89980	VIS	2				0.02	0.044
080	7L500-89990	NUT	2				0.001	0.0022
090	04512-60080	WASHER SPRING	2				0.002	0.0044

Fig.No.  
F150

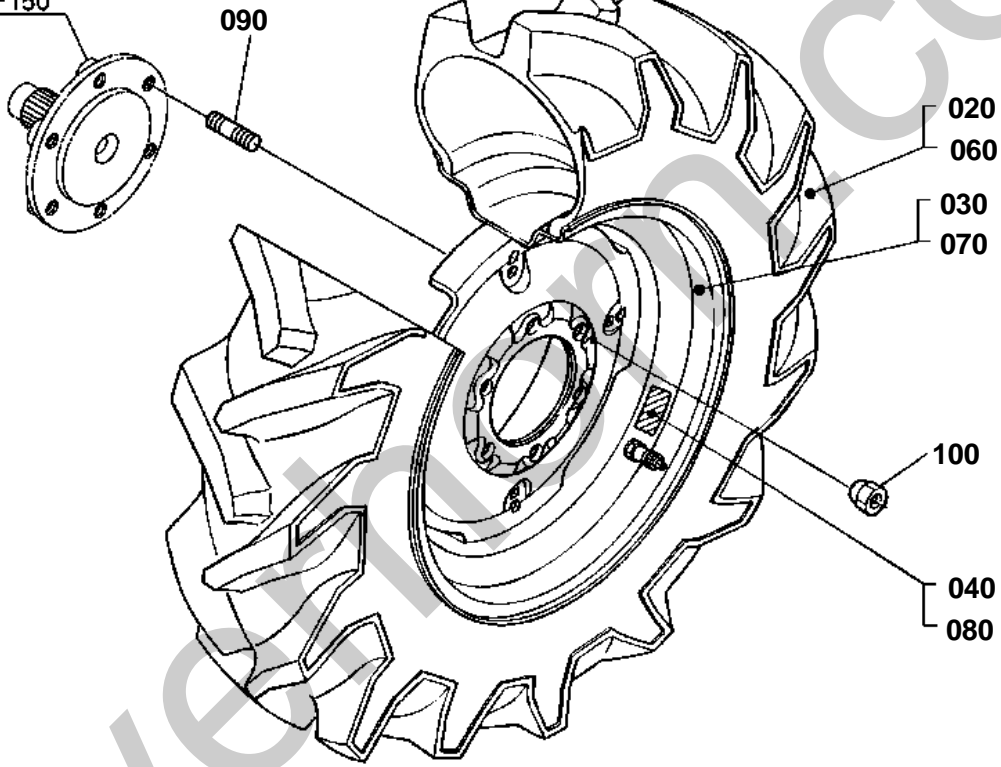

TC220-110-10



## FRONT WHEEL (7-16)

↔ Interchangeable; ≠ not interchangeable; ← new for old; → old for new

REF.No	Part No.	Description	Q'ty	S.No.	I/C	REMARKS	Weight (kgf)	Weight (lb)
010	TD020-10730	ASSY FRONT WHEEL RH	1			ALR8866AR	0	0
020	TD020-43740	TIRE	1			ALR8866AR	14.5	31.9
030	66434-17640	WHEEL	1			ALR8866AR	11.3	24.86
040	99999-99999	LABEL RH	1			ALR8866AR	0	0
050	TD020-10740	ASSY FRONT WHEEL LH	1			ALR8866AL	0	0
060	TD020-43740	TIRE	1			ALR8866AL	14.5	31.9
070	66434-17640	WHEEL	1			ALR8866AL	11.3	24.86
080	99999-99999	LABEL LH	1			ALR8866AL	0	0
090	TA150-49160	STUD WHEEL	12				0.05	0.11
100	35340-11390	NUT	12				0.03	0.066

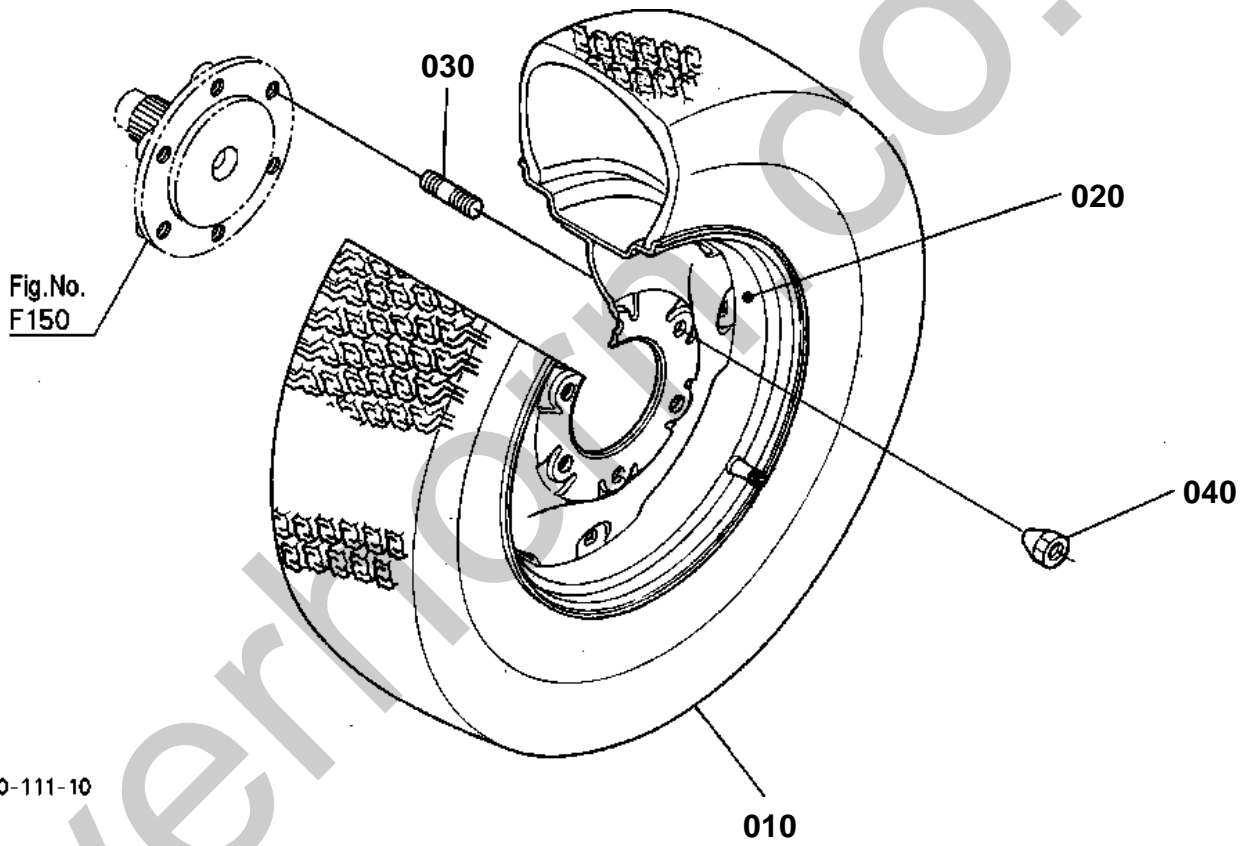

Fig.No.  
F150

TC220-111-10

Silverline.co.uk



FRONT WHEEL (25\*8.50-14)

↔ Interchangeable; ≠ not interchangeable; ← new for old; → old for new

REF.No	Part No.	Description	Q'ty	S.No.	I/C	REMARKS	Weight (kgf)	Weight (lb)
010	TA020-51810	TIRE	2			ALR8893A	0	0
020	35070-11650	WHEEL	2			ALR8893A	0	0
030	TA150-49160	STUD WHEEL	12				0.05	0.11
040	35340-11390	NUT	12				0.03	0.066



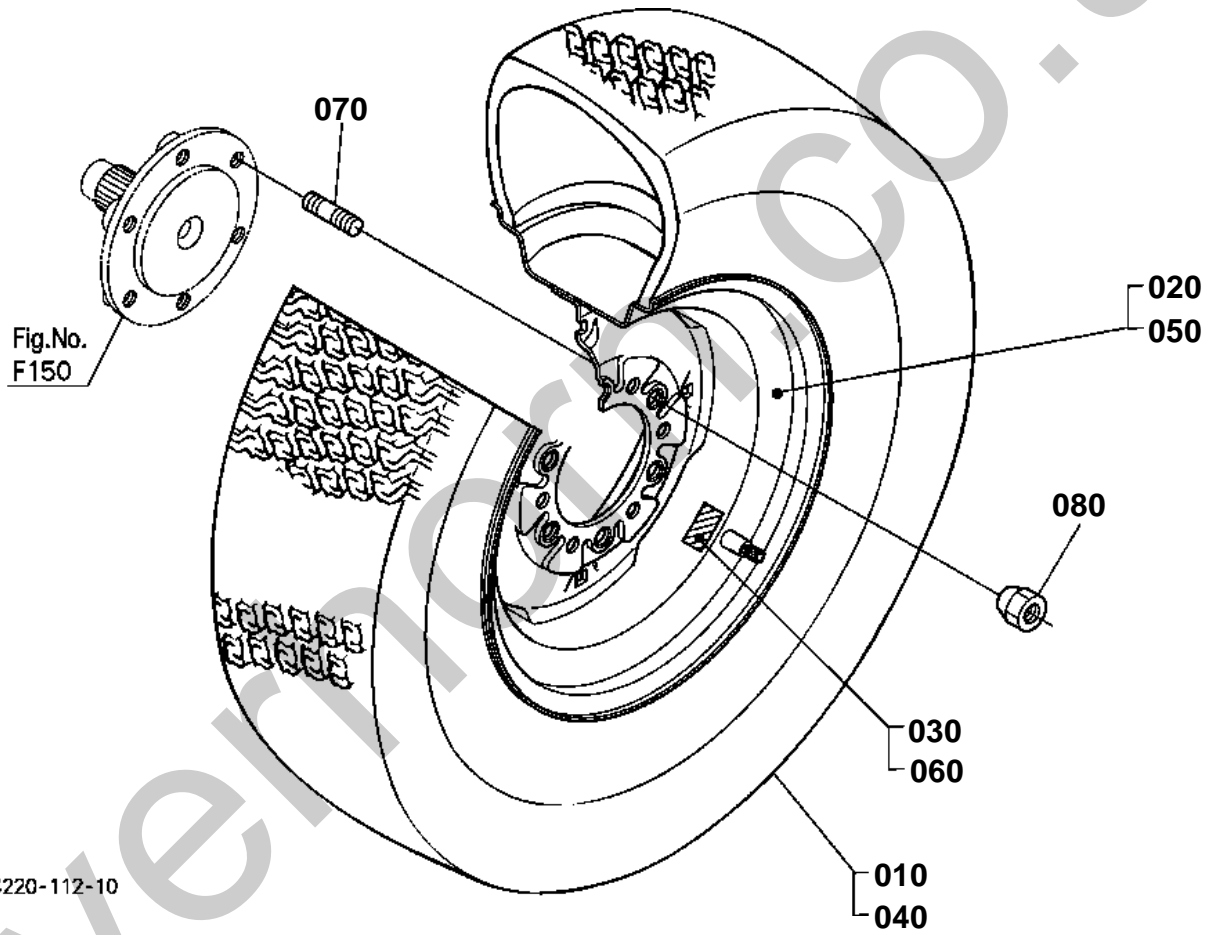



FRONT WHEEL (27\*8.50-15)

↔ Interchangeable; ≠ not interchangeable; ← new for old; → old for new

REF.No	Part No.	Description	Q'ty	S.No.	I/C	REMARKS	Weight (kgf)	Weight (lb)
010	67002-17630	TIRE	1			AMR8977R	0	0
020	3A999-11410	WHEEL	1			AMR8977R	0	0
030	99999-99999	LABEL RH	1			AMR8977R	0	0
040	67002-17630	TIRE	1			AMR8977L	0	0
050	3A999-11410	WHEEL	1			AMR8977L	0	0
060	99999-99999	LABEL LH	1			AMR8977L	0	0
070	TA150-49160	STUD WHEEL	12				0.05	0.11
080	35340-11390	NUT	12				0.03	0.066

REAR WHEEL (11.2-24)

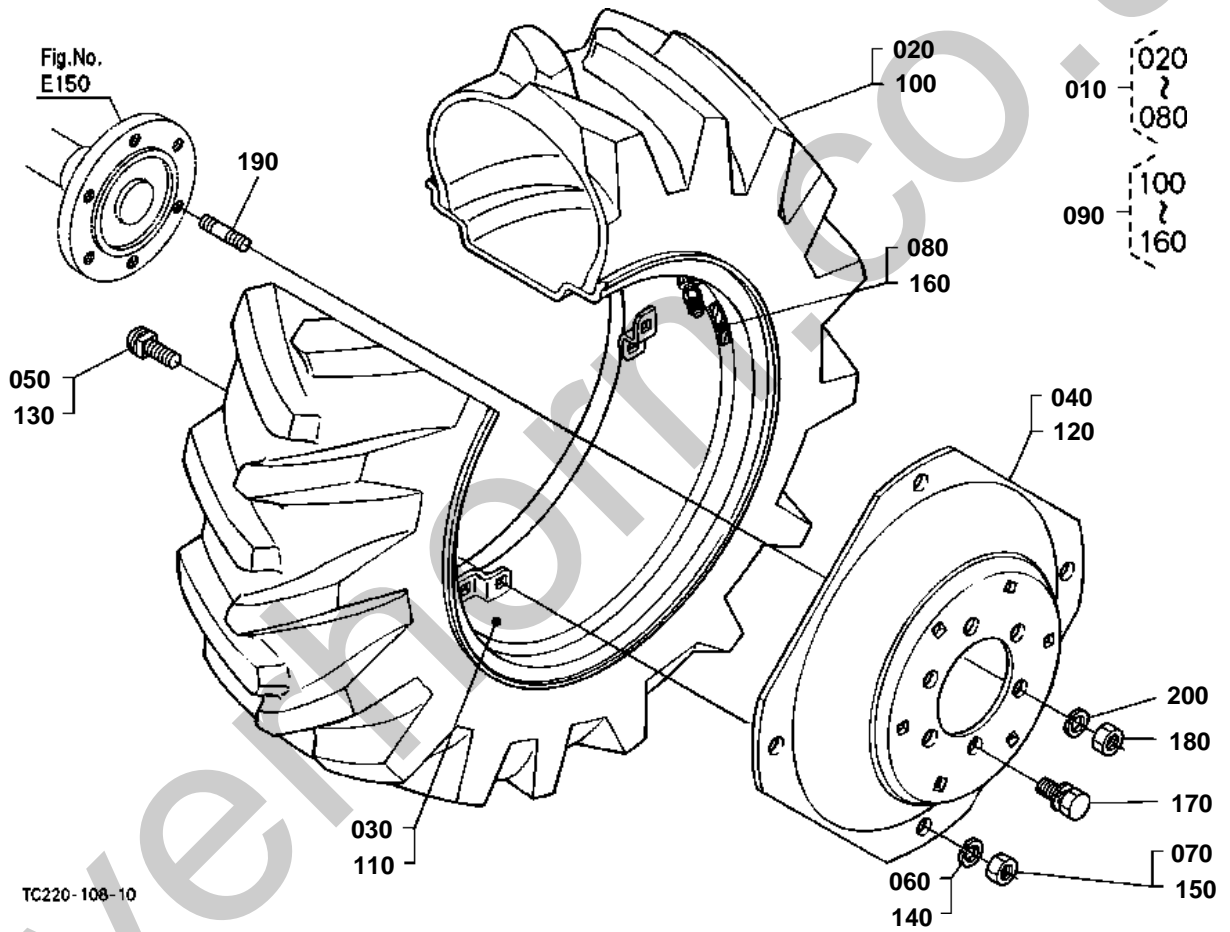



## REAR WHEEL (11.2-24)

↔ Interchangeable; ≠ not interchangeable; ← new for old; → old for new

REF.No	Part No.	Description	Q'ty	S.No.	I/C	REMARKS	Weight (kgf)	Weight (lb)
010	TC220-00830	ASSY REAR WHEEL RH	1			ALR8810AR	0	0
020	TC220-00850	TIRE	1			ALR8810AR	0	0
030	35070-27640	RIM	1			ALR8810AR	0	0
040	35080-27660	DISK	1			ALR8810AR	16.9	37.18
050	31220-27680	BOLT	4			ALR8810AR	0.09	0.198
060	75599-33017	WASHER SPRING LOCK	4			ALR8810AR	0.005	0.011
070	02174-50160	NUT	4			ALR8810AR	0.022	0.0484
080	99999-99999	LABEL RH	1			ALR8810AR	0	0
090	TC220-00840	ASSY REAR WHEEL LH	1			ALR8810AR	0	0
100	TC220-00850	TIRE	1			ALR8810AL	0	0
110	35070-27640	RIM	1			ALR8810AL	0	0
120	35080-27660	DISK	1			ALR8810AL	16.9	37.18
130	31220-27680	BOLT	4			ALR8810AL	0.09	0.198
140	75599-33017	WASHER SPRING LOCK	4			ALR8810AL	0.005	0.011
150	02174-50160	NUT	4			ALR8810AL	0.022	0.0484
160	99999-99999	LABEL LH	1			ALR8810AL	0	0
170	01033-51630	BOLT	8				0.09	0.198
180	02076-50160	NUT	4				0.03	0.066
190	01517-51632	STUD	4				0.076	0.1672
200	04512-60160	WASHER SPRING	4				0.01	0.022

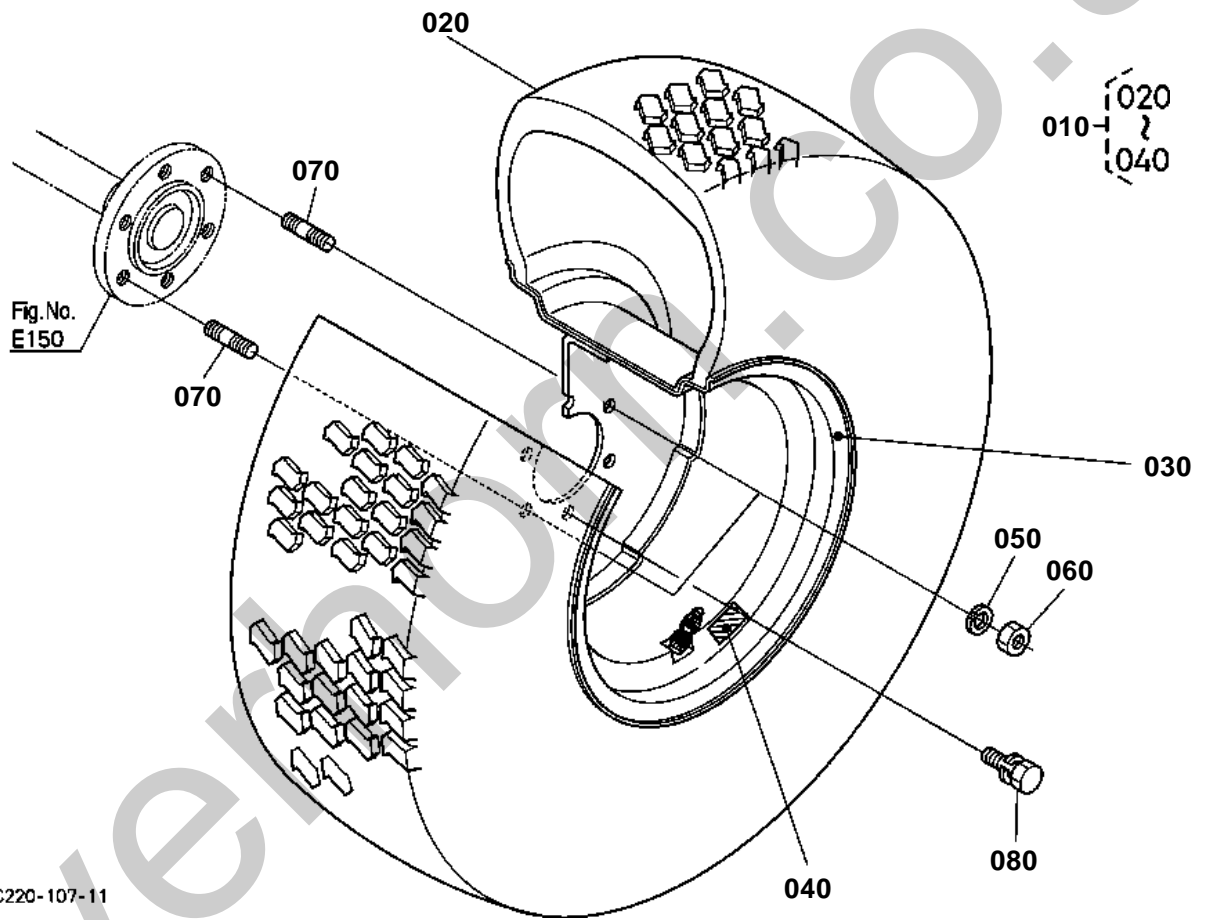



## REAR WHEEL (13.6-16)

↔ Interchangeable; ≠ not interchangeable; ← new for old; → old for new

REF.No	Part No.	Description	Q'ty	S.No.	I/C	REMARKS	Weight (kgf)	Weight (lb)
010	TC220-00510	ASSY REAR WHEEL	2			ALR8804A	0	0
020	6C070-50340	TIRE	2			ALR8804A	0	0
030	35040-27850	WHEEL	2			ALR8804A	0	0
040	99999-99999	LABEL TIRE	2			ALR8804A	0	0
050	04512-60160	WASHER SPRING	4				0.01	0.022
060	02076-50160	NUT	4				0.03	0.066
070	01517-51632	STUD	4				0.076	0.1672
080	01033-51630	BOLT	8				0.09	0.198

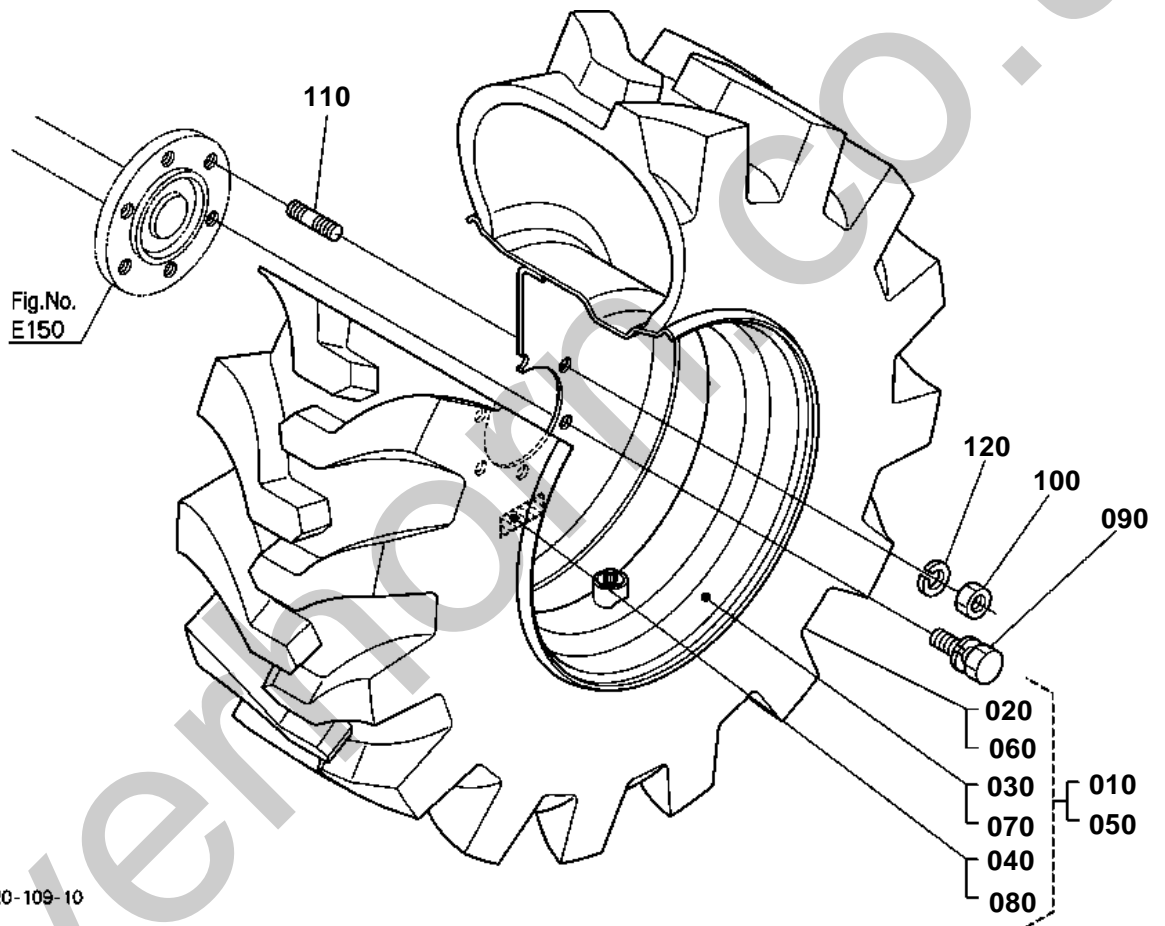



## REAR WHEEL (15-19.5)

↔ Interchangeable; ≠ not interchangeable; ← new for old; → old for new

REF.No	Part No.	Description	Q'ty	S.No.	I/C	REMARKS	Weight (kgf)	Weight (lb)
010	TC020-50850	ASSY REAR WHEEL	1			ALR8809R	0	0
020	32751-50830	TIRE	1			ALR8809R	0	0
030	TC020-50840	WHEEL	1			ALR8809R	41.8	91.96
040	99999-99999	LABEL TIRE RH	1			ALR8809R	0	0
050	TC020-50870	ASSY REAR WHEEL	1			ALR8809L	0	0
060	32751-50830	TIRE	1			ALR8809L	0	0
070	TC020-50840	WHEEL	1			ALR8809L	41.8	91.96
080	99999-99999	LABEL TIRE LH	1			ALR8809L	0	0
090	01033-51630	BOLT	8				0.09	0.198
100	02076-50160	NUT	4				0.03	0.066
110	01517-51632	STUD	4				0.076	0.1672
120	04512-60160	WASHER SPRING	4				0.01	0.022



LABEL 1 (FRONT) [EXCEPT HST TYPE]

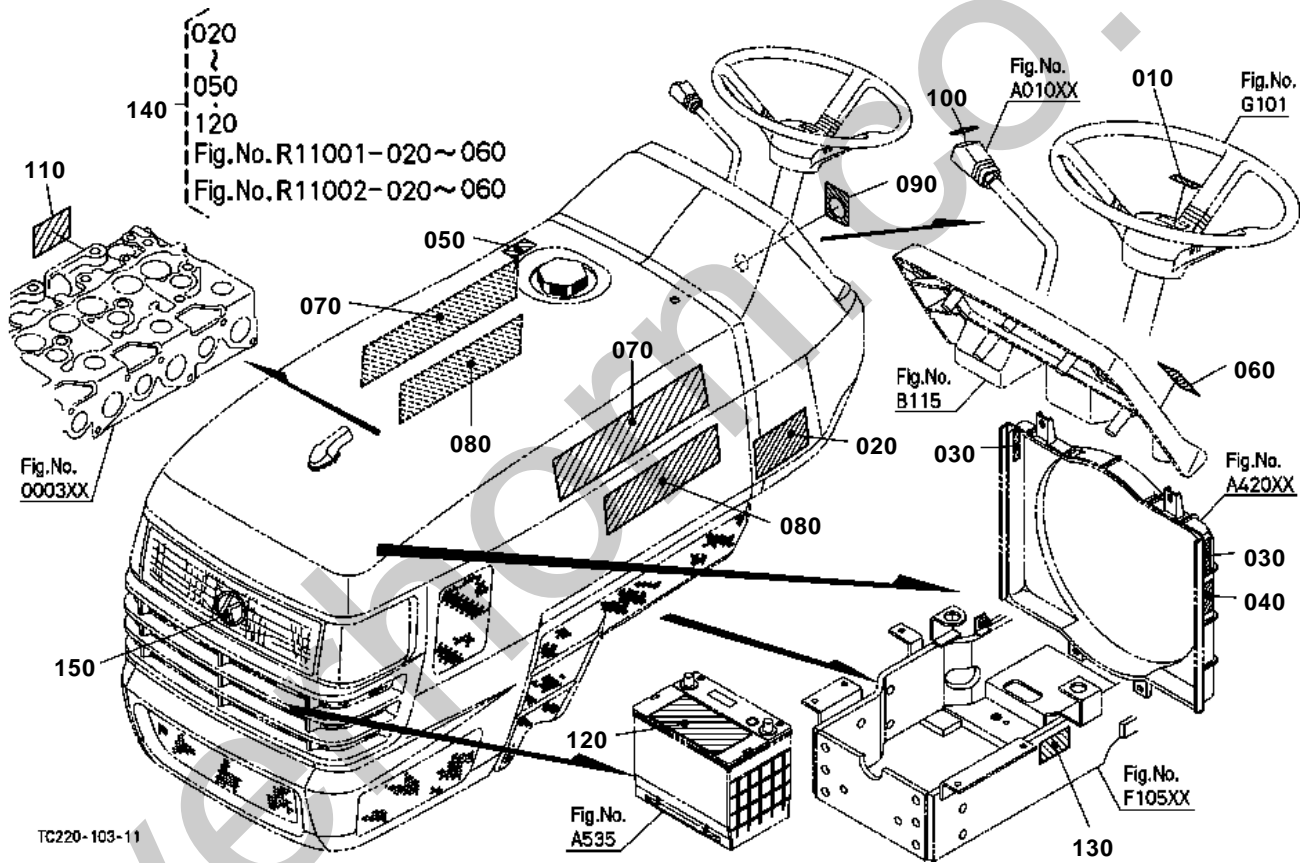



**LABEL 1 (FRONT) [EXCEPT HST TYPE]**

↔ Interchangeable; ≠ not interchangeable; ← new for old; → old for new

REF.No	Part No.	Description	Q'ty	S.No.	I/C	REMARKS	Weight (kgf)	Weight (lb)
010	6C040-41440	MARK STEERING	1				0.001	0.0022
020	TA040-49650	LABEL START CAUTION	1			ENGLISH	0.004	0.0088
020	TA041-49650	LABEL START CAUTION	1			FRENCH	0.004	0.0088
030	6C090-49580	LABEL FAN WARNING	2				0.001	0.0022
040	TC030-49580	LABEL MUFFLER	1				0.001	0.0022
050	TA040-49562	LABEL FUEL	1				0.002	0.0044
060	35260-25050	LABEL SHUTTLE	1			ENGLISH	0.01	0.022
060	35261-25050	LABEL SHUTTLE	1			FRENCH	0.001	0.0022
070	TC220-80930	LABEL KUBOTA	2				0.013	0.0286
080	TC210-49420	MARK MODEL	2				0.017	0.0374
090	TC020-65510	LABEL MAIN SWITCH	1				0.001	0.0022
100	TA040-49370	MARK ACCEL.GRIP	1				0.001	0.0022
110	1G790-87210	LABEL PUMP	1			ENGLISH	0.001	0.0022
110	1G851-87210	LABEL PUMP	1			FRENCH	0.001	0.0022
120	TD020-30122	LABEL BATTERY	1			ENGLISH	0.004	0.0088
120	TD021-30120	LABEL BATTERY	1			FRENCH	0.004	0.0088
130	99999-99999	NAME PLATE	1			ENGLISH	0	0
140	TC220-99500	KIT LABEL SAFETY (A)	1	≤52262		ENGLISH NOT SALE	0.025	0.055
140	TC220-99502	KIT LABEL SAFETY (A)	1	≥52263	→	ENGLISH	0.025	0.055
140	TC221-99500	KIT LABEL SAFETY (B)	1	≤52262		FRENCH	0	0
140	TC221-99502	KIT LABEL SAFETY (B)	1	≥52263	→	FRENCH	0.025	0.055
150	TA140-49500	MARK SYMBOL	1				0.013	0.0286

LABEL 1 (FRONT) [HST TYPE]

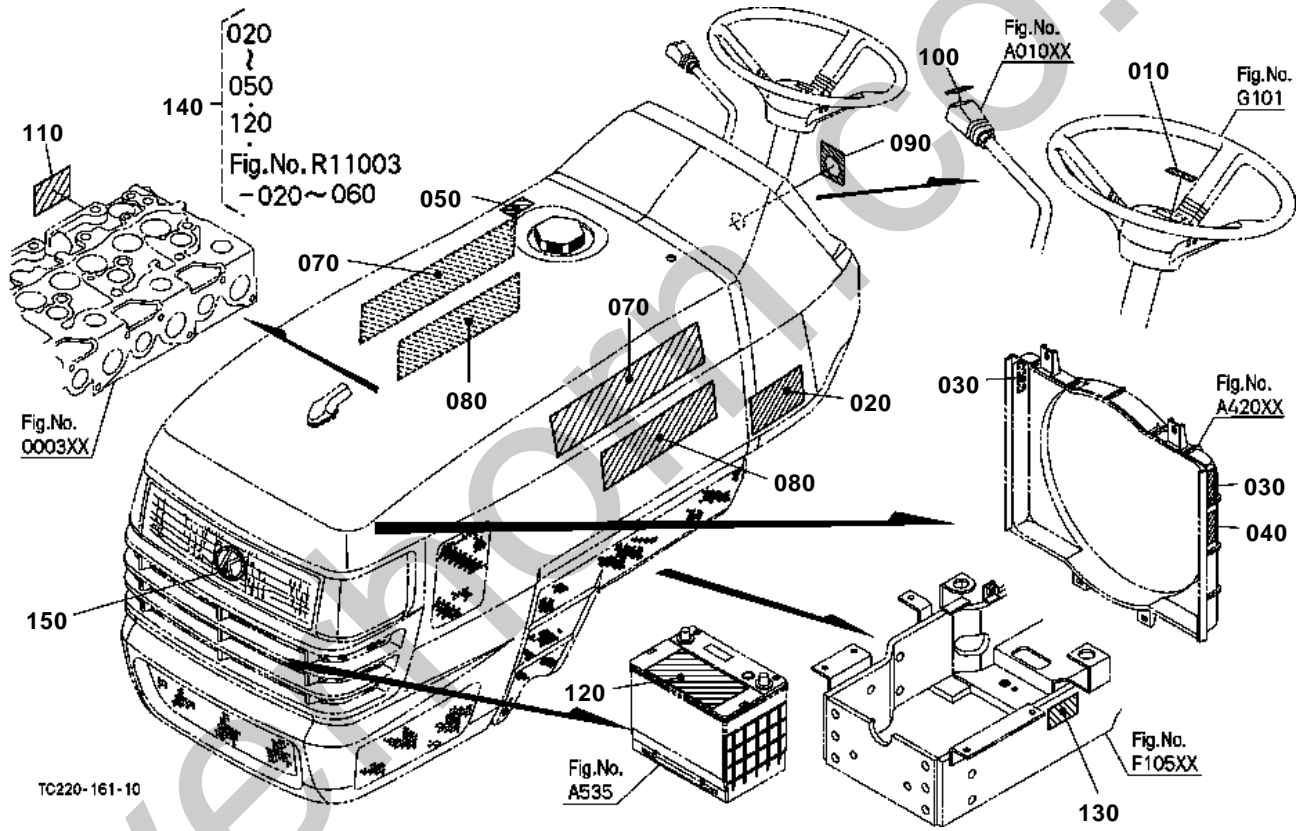

**LABEL 1 (FRONT) [HST TYPE]**

↔ Interchangeable; ≠ not interchangeable; ← new for old; → old for new

REF.No	Part No.	Description	Q'ty	S.No.	I/C	REMARKS	Weight (kgf)	Weight (lb)
010	6C040-41440	MARK STEERING	1				0.001	0.0022
020	TA040-49650	LABEL START CAUTION	1			ENGLISH	0.004	0.0088
020	TA041-49650	LABEL START CAUTION	1			FRENCH	0.004	0.0088
030	6C090-49580	LABEL FAN WARNING	2				0.001	0.0022
040	TC030-49580	LABEL MUFFLER	1				0.001	0.0022
050	TA040-49562	LABEL FUEL	1				0.002	0.0044
060	99999-99999	BLANK	0				0	0
070	TC220-80930	LABEL KUBOTA	2				0.013	0.0286
080	TC210-49420	MARK MODEL	2				0.017	0.0374
090	TC020-65510	LABEL MAIN SWITCH	1				0.001	0.0022
100	TA040-49370	MARK ACCEL.GRIP	1				0.001	0.0022
110	1G790-87210	LABEL PUMP	1			ENGLISH	0.001	0.0022
110	1G851-87210	LABEL PUMP	1			FRENCH	0.001	0.0022
120	TD020-30122	LABEL BATTERY	1			ENGLISH	0.004	0.0088
120	TD021-30120	LABEL BATTERY	1			FRENCH	0.004	0.0088
130	99999-99999	NAME PLATE	1				0	0
140	TC220-99502	KIT LABEL SAFETY (A)	1			ENGLISH	0.025	0.055
140	TC221-99502	KIT LABEL SAFETY (B)	1			FRENCH	0.025	0.055
150	TA140-49500	MARK SYMBOL	1				0.013	0.0286

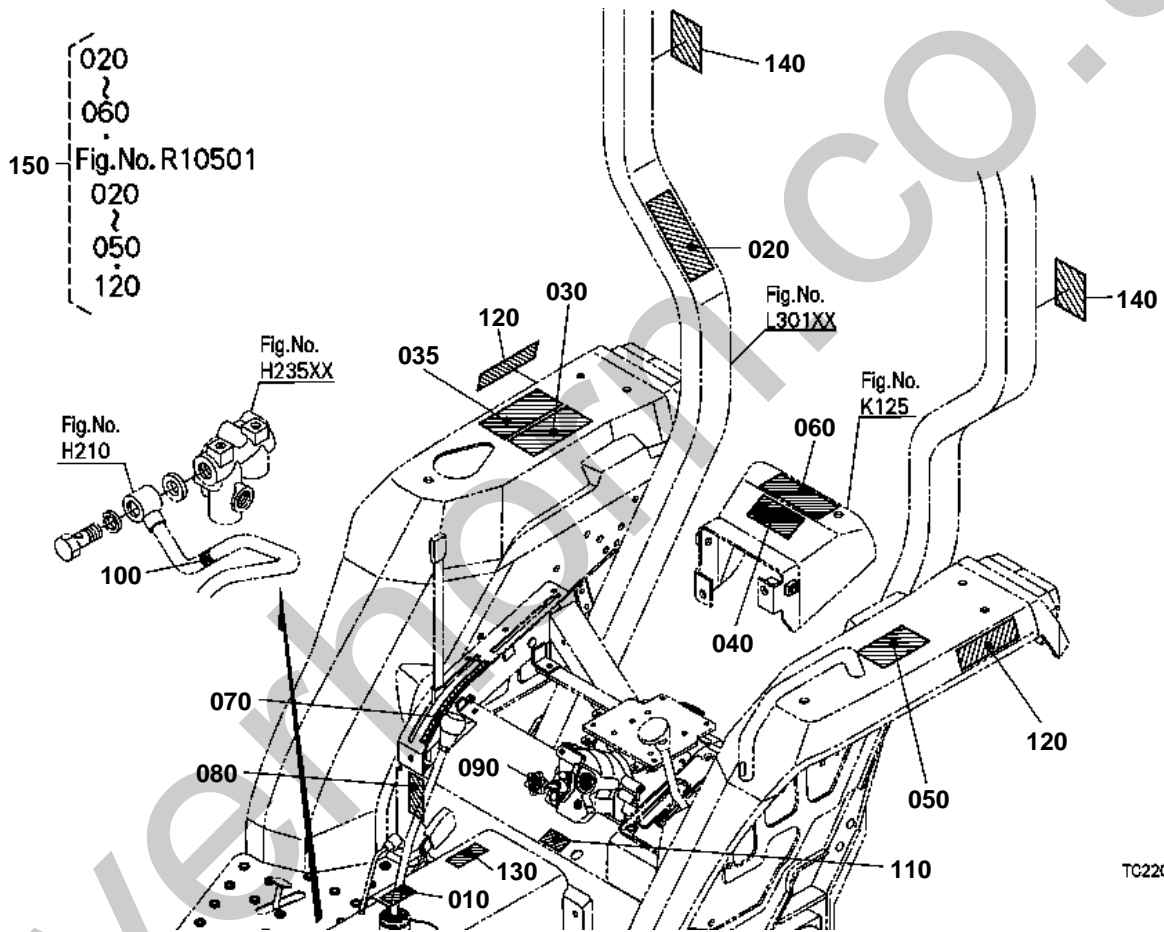

TC220-104-11



LABEL 2 (REAR) [EXCEPT HST TYPE]

↔ Interchangeable; ≠ not interchangeable; ← new for old; → old for new

REF.No	Part No.	Description	Q'ty	S.No.	I/C	REMARKS	Weight (kgf)	Weight (lb)
010	TA040-49460	LABEL PARKING	1				0.001	0.0022
020	6C140-47460	LABEL ROPS WARNING	1			ENGLISH RIGID ROPS TYPE	0.001	0.0022
020	6C141-47460	LABEL ROPS WARNING	1			FRENCH RIGID ROPS TYPE	0.001	0.0022
020	3A111-95540	LABEL ROPS CAUTION	1			ENGLISH FOLDABLE ROPS TYPE	0.003	0.0066
020	3A112-95540	LABEL ROPS CAUTION	1			FRENCH FOLDABLE ROPS TYPE	0.003	0.0066
030	TA040-49320	LABEL ROPS WARNING	1			ENGLISH RIGID ROPS TYPE	0.001	0.0022
030	TA040-49150	LABEL ROPS WARNING	1			FRENCH RIGID ROPS TYPE	0.003	0.0066
030	TA240-98480	LABEL ROPS WARNING	1			ENGLISH FOLDABLE ROPS TYPE	0.005	0.011
030	3A112-98480	LABEL ROPS WARNING	1			FRENCH FOLDABLE ROPS TYPE	0.004	0.0088
035	TA140-49330	LABEL SHUTTLE	1	>=52263		ENGLISH	0.005	0.011
035	TA141-49330	LABEL SHUTTLE	1	>=52263		FRENCH	0.005	0.011
035	TA240-49330	LABEL PARKING	1	>=52263		ENGLISH OUT OF USE	0.005	0.011
035	TA241-49330	LABEL PARKING	1	>=52263		FRENCH OUT OF USE	0.005	0.011
040	TA040-49350	LABEL DRAWBAR	1			ENGLISH	0.002	0.0044
040	TA041-49350	LABEL DRAWBAR	1			FRENCH	0.003	0.0066
050	35260-34914	LABEL SAFETY	1			ENGLISH	0.005	0.011
050	TA041-65702	LABEL SAFETY	1			FRENCH	0.01	0.022
060	TA040-49593	LABEL PTO WARNING	1			ENGLISH	0.001	0.0022
060	TA041-49590	LABEL PTO WARNING	1			FRENCH	0.001	0.0022
070	TA040-49500	MARK POSITION	1				0.002	0.0044
080	TA040-49760	MARK DIFF.LOCK	1				0.001	0.0022
090	TA470-49330	MARK HYD.ADJUST.	1				0.001	0.0022
100	32430-65790	LABEL HYD.BLOCK	1				0.01	0.022
110	3A121-98650	LABEL 4WD	1				0.001	0.0022
120	K2571-65250	LABEL 4WD	2				0.002	0.0044
130	TC220-49160	MARK PTO	1				0.001	0.0022
140	6C140-54990	REFLECTOR LABEL	2				0.003	0.0066
150	TC220-99500	KIT LABEL SAFETY (A)	1	<=52262		ENGLISH NOT SALE	0.025	0.055
150	TC220-99502	KIT LABEL SAFETY (A)	1	>=52263	→	ENGLISH	0.025	0.055
150	TC221-99500	KIT LABEL SAFETY (B)	1	<=52262		FRENCH	0	0
150	TC221-99502	KIT LABEL SAFETY (B)	1	>=52263	→	FRENCH	0.025	0.055

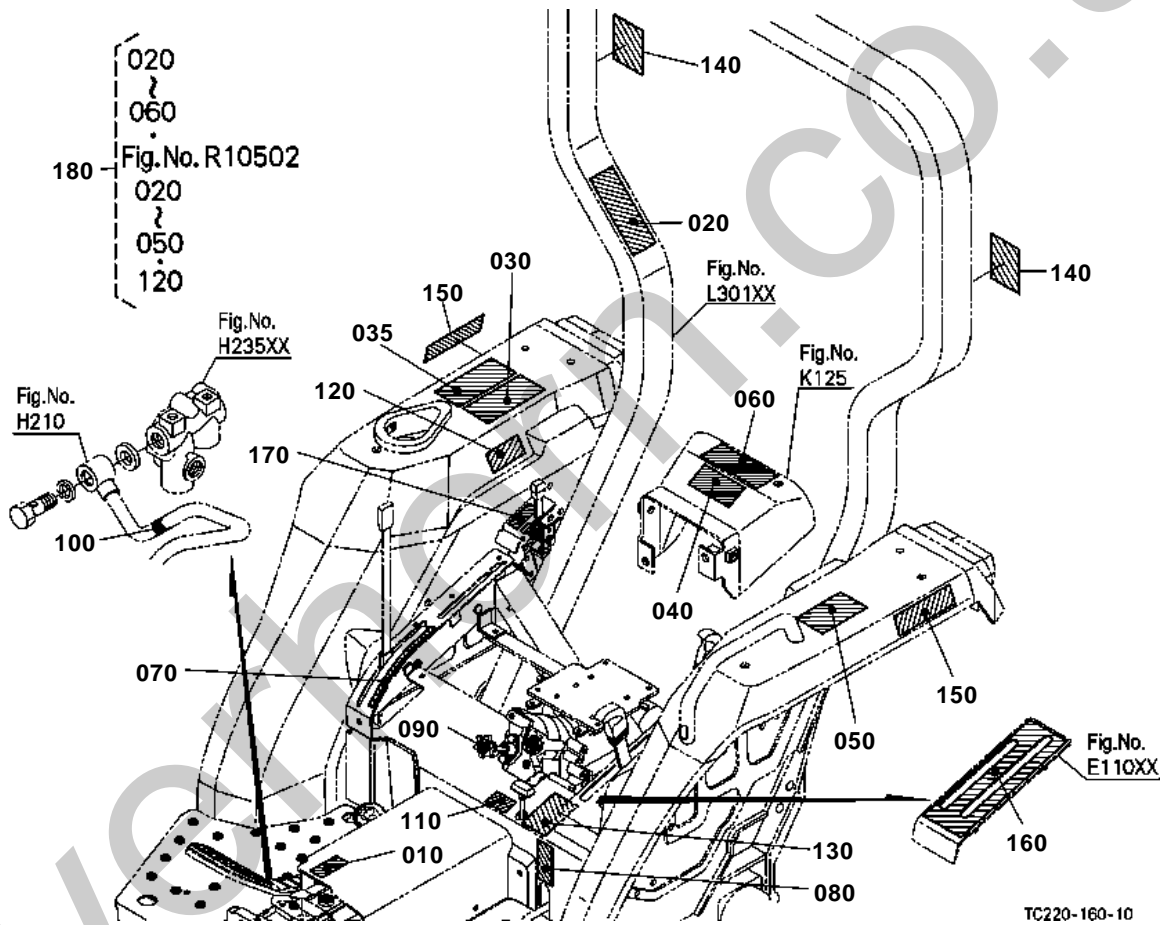



LABEL 2 (REAR) [HST TYPE]

↔ Interchangeable; ≠ not interchangeable; ← new for old; → old for new

REF.No	Part No.	Description	Q'ty	S.No.	I/C	REMARKS	Weight (kgf)	Weight (lb)
010	TA040-49460	LABEL PARKING	1				0.001	0.0022
020	6C140-47460	LABEL ROPS WARNING	1			ENGLISH RIGID ROPS TYPE	0.001	0.0022
020	6C141-47460	LABEL ROPS WARNING	1			FRENCH RIGID ROPS TYPE	0.001	0.0022
020	3A111-95540	LABEL ROPS CAUTION	1			ENGLISH FOLDABLE ROPS TYPE	0.003	0.0066
020	3A112-95540	LABEL ROPS CAUTION	1			FRENCH FOLDABLE ROPS TYPE	0.003	0.0066
030	TA040-49320	LABEL ROPS WARNING	1			ENGLISH RIGID ROPS TYPE	0.001	0.0022
030	TA040-49150	LABEL ROPS WARNING	1			FRENCH RIGID ROPS TYPE	0.003	0.0066
030	TA240-98480	LABEL ROPS WARNING	1			ENGLISH FOLDABLE ROPS TYPE	0.005	0.011
030	3A112-98480	LABEL ROPS WARNING	1			FRENCH FOLDABLE ROPS TYPE	0.004	0.0088
035	TA240-49330	LABEL PARKING	1			ENGLISH	0.005	0.011
035	TA241-49330	LABEL PARKING WARNIN	1			FRENCH	0.005	0.011
035	TA140-49330	LABEL SHUTTLE	1			ENGLISH OUT OF USE	0.005	0.011
035	TA141-49330	LABEL SHUTTLE	1			FRENCH OUT OF USE	0.005	0.011
040	TA040-49350	LABEL DRAWBAR	1			ENGLISH	0.002	0.0044
040	TA041-49350	LABEL DRAWBAR	1			FRENCH	0.003	0.0066
050	35260-34914	LABEL SAFETY	1			ENGLISH	0.005	0.011
050	TA041-65702	LABEL SAFETY	1			FRENCH	0.01	0.022
060	TA040-49593	LABEL PTO WARNING	1			ENGLISH	0.001	0.0022
060	TA041-49590	LABEL PTO WARNING	1			FRENCH	0.001	0.0022
070	TA040-49500	MARK POSITION	1				0.002	0.0044
080	TA040-49760	MARK DIFF.LOCK	1				0.001	0.0022
090	TA470-49330	MARK HYD.ADJUST.	1				0.001	0.0022
100	32430-65790	LABEL HYD.BLOCK	1				0.01	0.022
110	3A121-98650	LABEL 4WD	1				0.001	0.0022
120	TA040-49310	LABEL PTO CAUTION	1				0.002	0.0044
130	TD060-57852	LABEL	1				0.002	0.0044
140	6C140-54990	REFLECTOR LABEL	2				0.003	0.0066
150	TD060-57610	MARK HST FENDER	2				0.002	0.0044
160	TC220-57582	LABEL CHANGE GUIDE	1				0.015	0.033
170	TA040-49160	MARK REAR PTO	1				0.001	0.0022
180	TC220-99502	KIT LABEL SAFETY (A)	1			ENGLISH	0.025	0.055
180	TC221-99502	KIT LABEL SAFETY (B)	1			FRENCH	0.025	0.055



**ACCESSORIES AND SERVICE PARTS  
ACCESSOIRES ET PIECES DE SERVICE  
SONTIGES ZUBEHOER UND SERVICE-TEILE**

TITLE-001-10



## ACCESSORIES AND SERVICE PARTS

↔ Interchangeable; ≠ not interchangeable; ← new for old; → old for new

REF.No	Part No.	Description	Q'ty	S.No.	I/C	REMARKS	Weight (kgf)	Weight (lb)
010	TC220-19710	OPERATOR'S MANUAL	1	<=52427		ENGLISH	0	0
010	TC220-19712	OPERATOR'S MANUAL	1	>=52428	-	ENGLISH	0.18	0.396
020	TC221-19710	OPERATOR'S MANUAL	1	<=52427		FRENCH	0	0
020	TC221-19712	OPERATOR'S MANUAL	1	>=52428	-	FRENCH	0	0
030	01033-51630	BOLT	8			FOR REAR WHEEL	0.09	0.198
040	01517-51632	STUD	4			FOR REAR WHEEL	0.076	0.1672
050	04512-60160	WASHER SPRING	4			FOR REAR WHEEL	0.01	0.022
060	02076-50160	NUT	4			FOR REAR WHEEL	0.03	0.066
070	TA150-49160	STUD WHEEL	12			FOR FRONT WHEEL	0.05	0.11
080	04512-60140	WASHER SPRING	12			FOR FRONT WHEEL	0.008	0.0176
090	04013-60140	WASHER PLAIN	12			FOR FRONT WHEEL	0.01	0.022
100	35340-11390	NUT	12			FOR FRONT WHEEL	0.03	0.066
110	35260-31852	ASSY KEY MAIN SWITCH	1				0.03	0.066
120	1G511-89810	STATEMENT WARRANTY	1	<=52262			0	0
120	1G511-89814	STATEMENT WARRANTY	1	>=52263	1		0.01	0.022

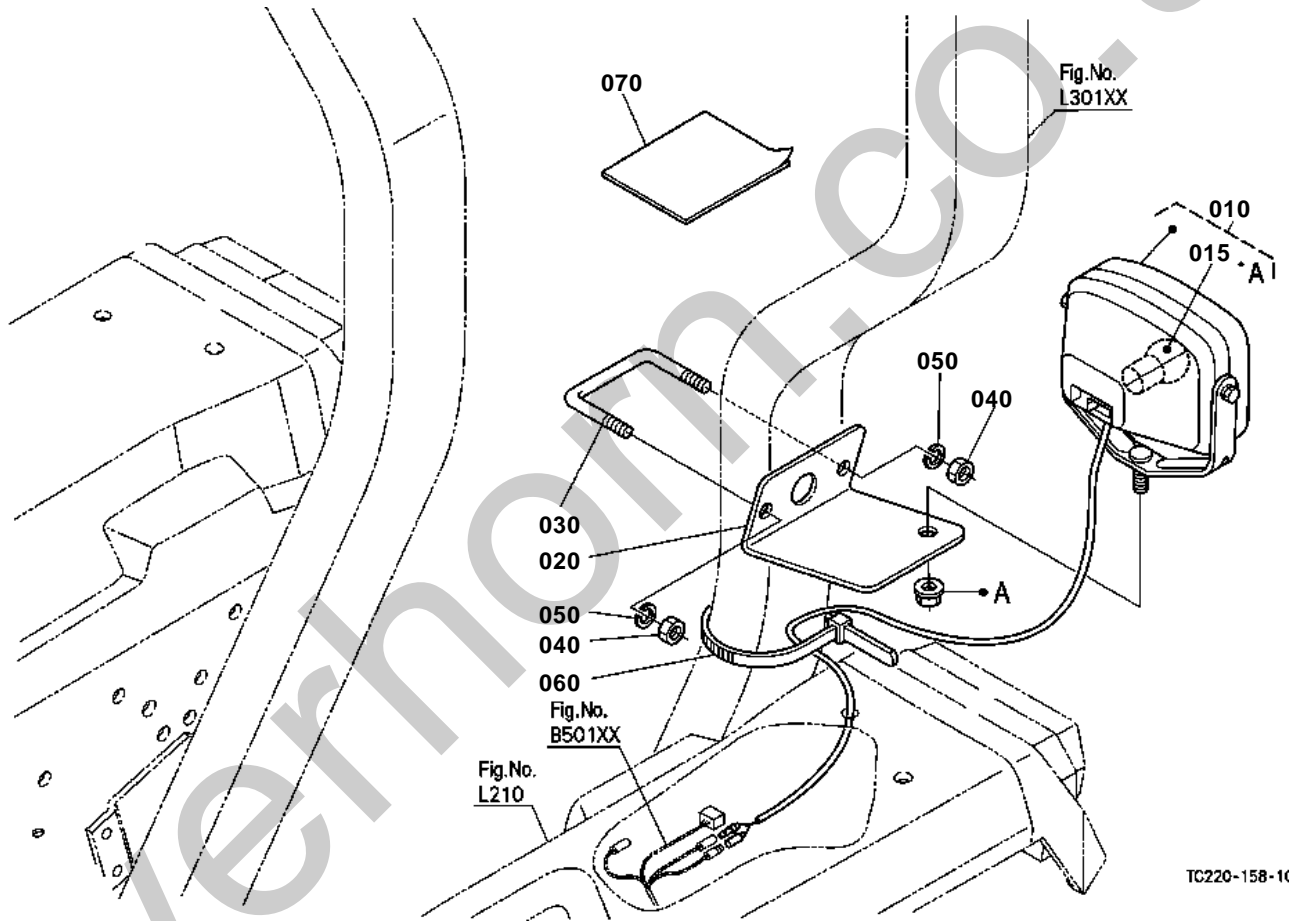

TC220-158-10

**WORKING LIGHT KIT(W/G No.M9551) [OPTION]**

↔ Interchangeable; ≠ not interchangeable; ← new for old; → old for new

REF.No	Part No.	Description	Q'ty	S.No.	I/C	REMARKS	Weight (kgf)	Weight (lb)
010	3A011-75903	ASSY LIGHT WORKING	1				0.64	1.408
015	3A011-75930	BULB	1			35W	0.008	0.0176
020	3A012-75910	STAY WORKING LIGHT	1				0.64	1.408
030	3A011-75922	U-BOLT	1				0.117	0.2574
040	02176-50100	NUT	2				0.005	0.011
050	04512-60100	WASHER SPRING	2				0.002	0.0044
060	32751-96300	BAND WORK LIGHT	1				0.005	0.011
070	99999-99999	MANUAL INSTRUCTION	1				0	0

FRONT BUMPER(W/G No.MX8068) [OPTION]

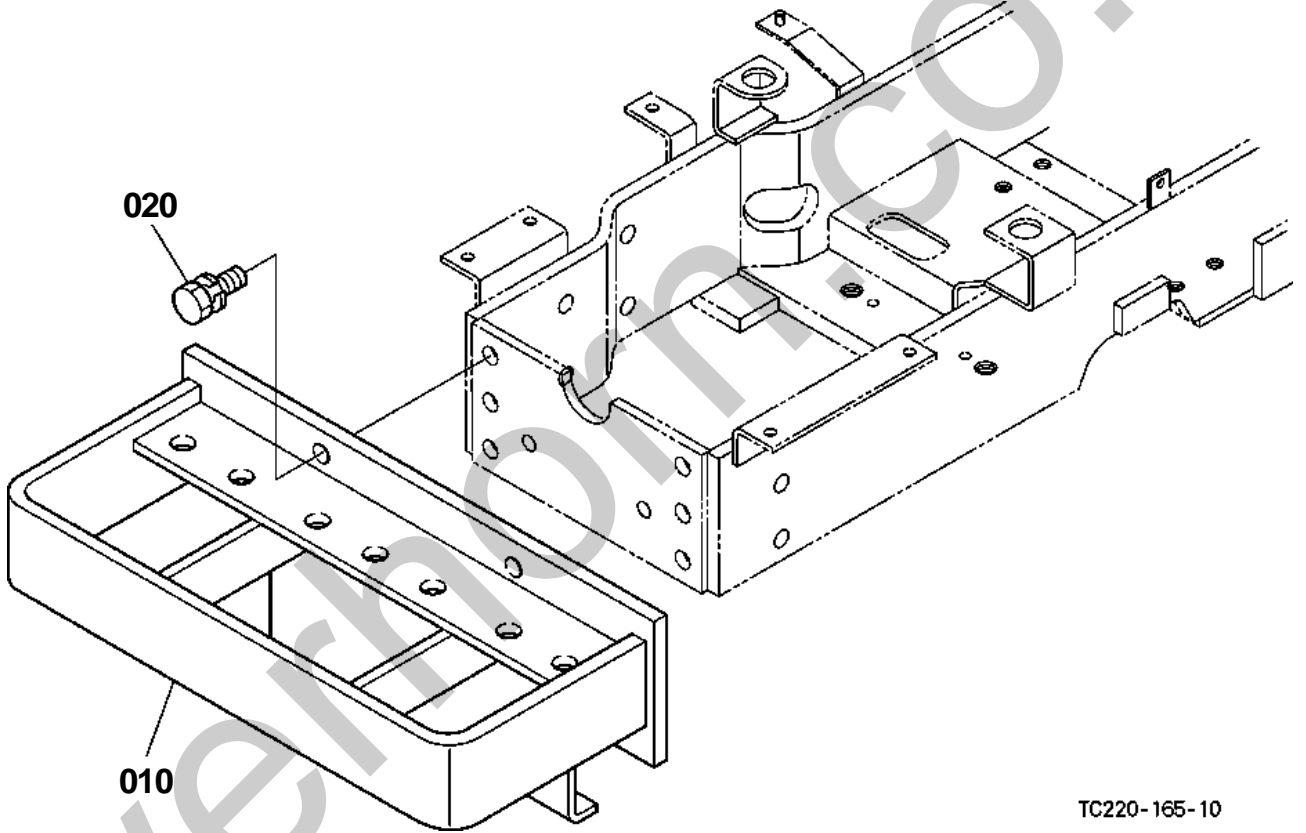

TC220-165-10



FRONT BUMPER(W/G No.MX8068) [OPTION]

↔ Interchangeable; ≠ not interchangeable; ← new for old; → old for new

REF.No	Part No.	Description	Q'ty	S.No.	I/C	REMARKS	Weight (kgf)	Weight (lb)
010	32430-44880	BUMPER	1				12.05	26.51
020	01133-51435	BOLT	4				0.001	0.0022

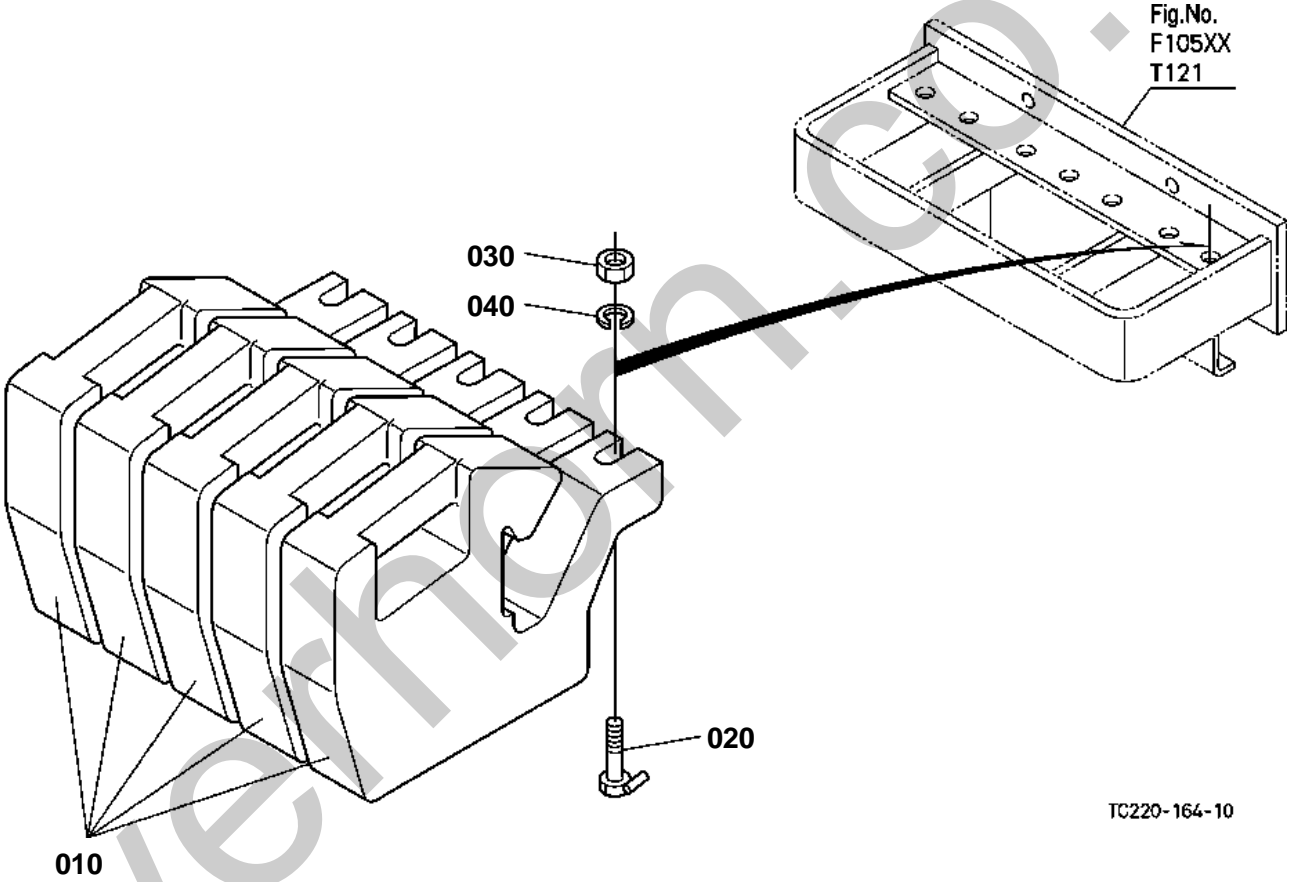

TC220-164-10



## FRONT WEIGHT [OPTION]

↔ Interchangeable; ≠ not interchangeable; ← new for old; → old for new

REF.No	Part No.	Description	Q'ty	S.No.	I/C	REMARKS	Weight (kgf)	Weight (lb)
010	96315-11614	WEIGHT FRONT	5			20kg	20	44
010	96315-11620	WEIGHT FRONT	5			25kg	25	55
020	96315-11630	BOLT FRONT WEIGHT	1				0.09	0.198
030	02174-50140	NUT	1				0.014	0.0308
040	04512-60140	WASHER SPRING	1				0.008	0.0176



REAR WHEEL WEIGHT [OPTION]

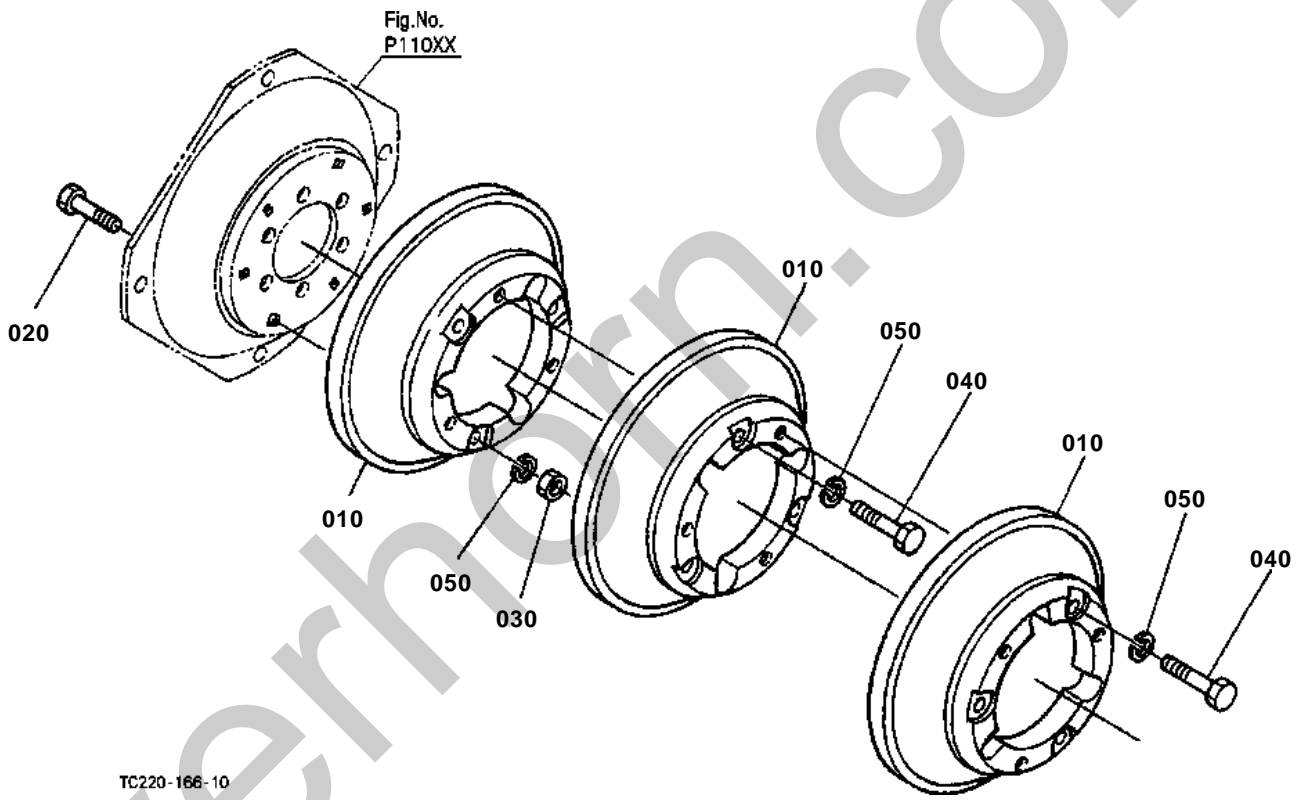



## REAR WHEEL WEIGHT [OPTION]

↔ Interchangeable; ≠ not interchangeable; ← new for old; → old for new

REF.No	Part No.	Description	Q'ty	S.No.	I/C	REMARKS	Weight (kgf)	Weight (lb)
010	99281-15110	WEIGHT REAR WHEEL	6				28	61.6
020	01173-51480	BOLT	6				0.103	0.2266
030	02074-50140	NUT	6				0.021	0.0462
040	01073-51475	BOLT	12				0.112	0.2464
050	04512-60140	WASHER SPRING	18				0.008	0.0176

CONTROL VALVE (WITH DRAFT) [OPTION]

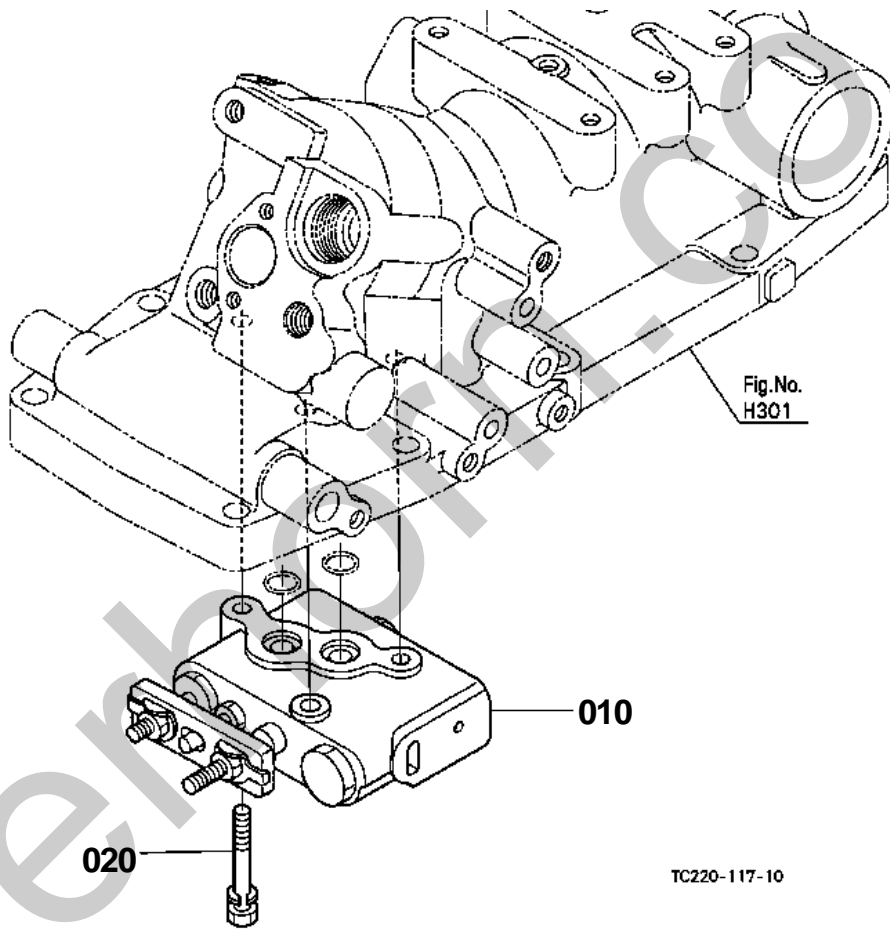

TC220-117-10



## CONTROL VALVE (WITH DRAFT) [OPTION]

↔ Interchangeable; ≠ not interchangeable; ← new for old; → old for new

REF.No	Part No.	Description	Q'ty	S.No.	I/C	REMARKS	Weight (kgf)	Weight (lb)
010	31351-39604	ASSY VALVE CONTROL	1				1.9	4.18
020	01123-50850	BOLT	1				0.02	0.044

CONTROL VALVE (WITH DRAFT) [COMPONENT PARTS] [OPTION]

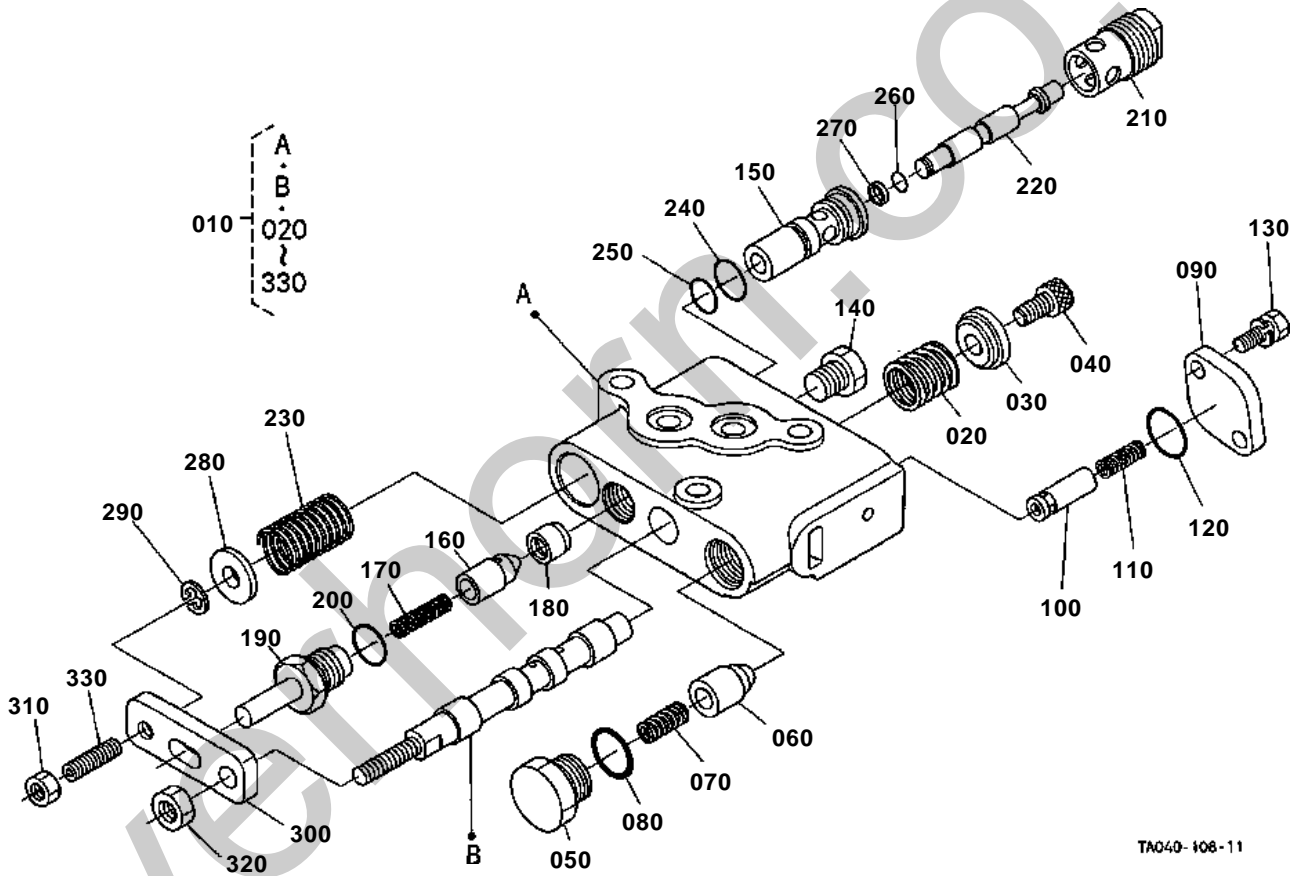

TA040-106-11

**CONTROL VALVE (WITH DRAFT) [COMPONENT PARTS] [OPTION]**

↔ Interchangeable; ≠ not interchangeable; ← new for old; → old for new

REF.No	Part No.	Description	Q'ty	S.No.	I/C	REMARKS	Weight (kgf)	Weight (lb)
010	31351-39604	ASSY VALVE CONTROL	1				1.9	4.18
020	31351-39630	SPRING SPOOL	1				0.02	0.044
030	31351-39640	HOLDER SPRING	1				0.02	0.044
040	01311-10814	BOLT HEX-SOC-HD	1				0.012	0.0264
050	31351-39650	PLUG	1				0.04	0.088
060	31351-39150	POPPET	1				0.02	0.044
070	67531-38470	SPRING	1				0.001	0.0022
080	04817-00140	O RING	1				0.001	0.0022
090	31351-39660	PLATE	1				0.05	0.11
100	31351-39670	POPPET	1				0.01	0.022
110	31351-39680	SPRING	1				0.01	0.022
120	04817-00160	O RING	1				0.001	0.0022
130	01023-50616	BOLT	2				0.005	0.011
140	06331-35010	PLUG	1				0.012	0.0264
150	T0430-37600	SLEEVE	1				0.05	0.11
160	T0430-37580	POPPET	1				0.01	0.022
170	31391-39190	SPRING	1				0.001	0.0022
180	T0430-37530	SEAT CHECK VALVE	1				0.005	0.011
190	31351-37670	PLUG	1				0.038	0.0836
200	04817-00120	O RING	1				0.001	0.0022
210	31351-37620	PLUG	1				0.045	0.099
220	T0430-37610	POPPET	1				0.018	0.0396
230	T0430-37620	SPRING	1				0.009	0.0198
240	04817-05120	O RING	1				0.001	0.0022
250	04817-05110	O RING	1				0.005	0.011
260	04816-00050	O RING	1				0.001	0.0022
270	31351-39290	RING BACK UP	1				0.001	0.0022
280	T0430-37640	WASHER PLAIN	1				0.002	0.0044
290	04613-50060	CIR CLIP EXTERNAL	1				0.001	0.0022
300	31351-39752	PLATE	1				0.05	0.11
310	02014-50060	NUT	1				0.002	0.0044
320	02114-50080	NUT	1				0.005	0.011
330	03650-50622	SCREW SET	1				0.004	0.0088

DRAFT CONTROL LEVER (WITH DRAFT) [OPTION]

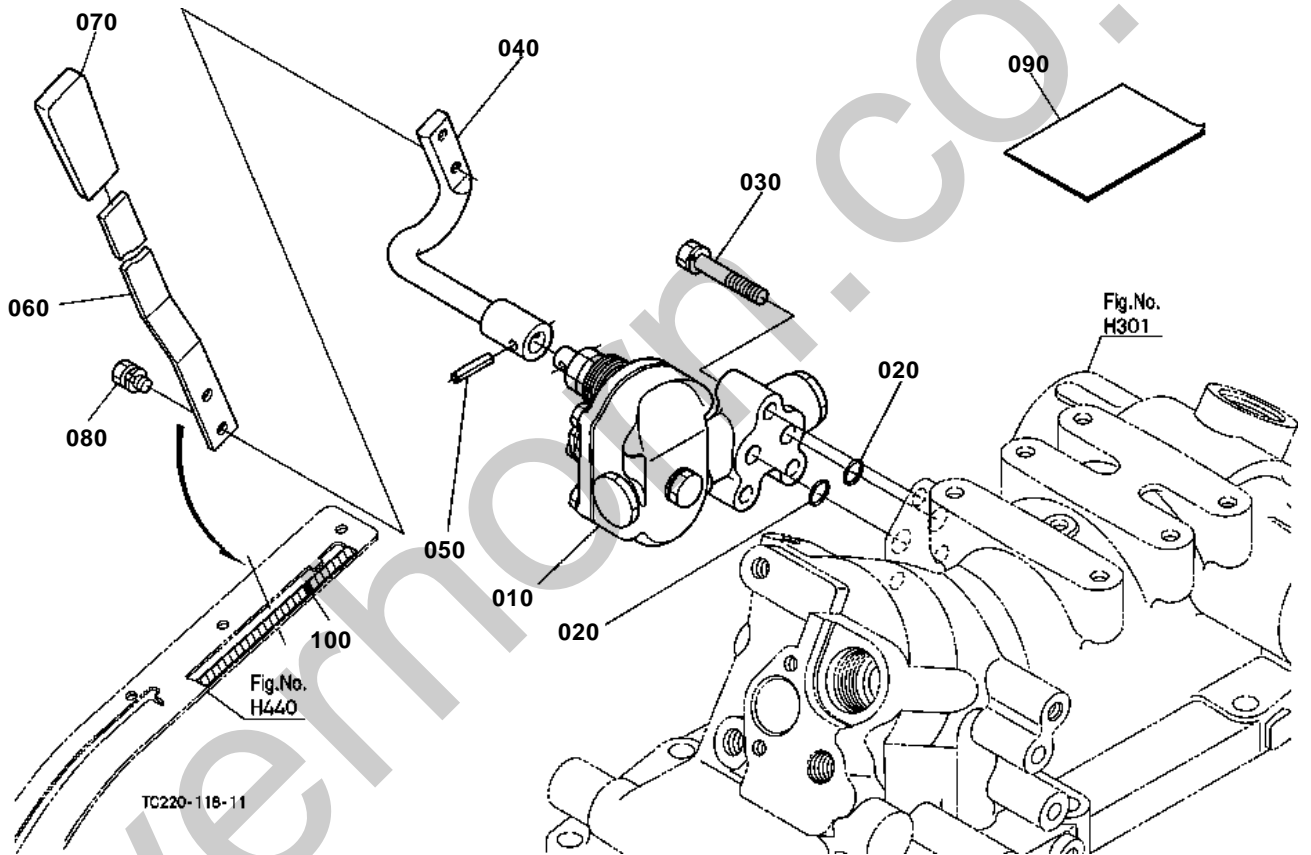



## DRAFT CONTROL LEVER (WITH DRAFT) [OPTION]

↔ Interchangeable; ≠ not interchangeable; ← new for old; → old for new

REF.No	Part No.	Description	Q'ty	S.No.	I/C	REMARKS	Weight (kgf)	Weight (lb)
010	35080-41100	ASSY VALVE DRAFT CON	1				2.5	5.5
020	04817-00140	O RING	2				0.001	0.0022
030	01123-50845	BOLT	3				0.02	0.044
040	35080-41240	LEVER DRAFT CON.	1				0.285	0.627
050	05411-00525	PIN SPRING	1				0.002	0.0044
060	TC022-41250	LEVER DRAFT	1				0.155	0.341
070	31351-36880	GRIP LEVER	1				0.04	0.088
080	01023-50612	BOLT	2				0.005	0.011
090	32430-98110	MANUAL ASSEMBLY	1				0.017	0.0374
100	32430-65770	LABEL DRAFT CON.	1				0.001	0.0022



DRAFT CONTROL VALVE (WITH DRAFT) [COMPONENT PARTS] [OPTION]

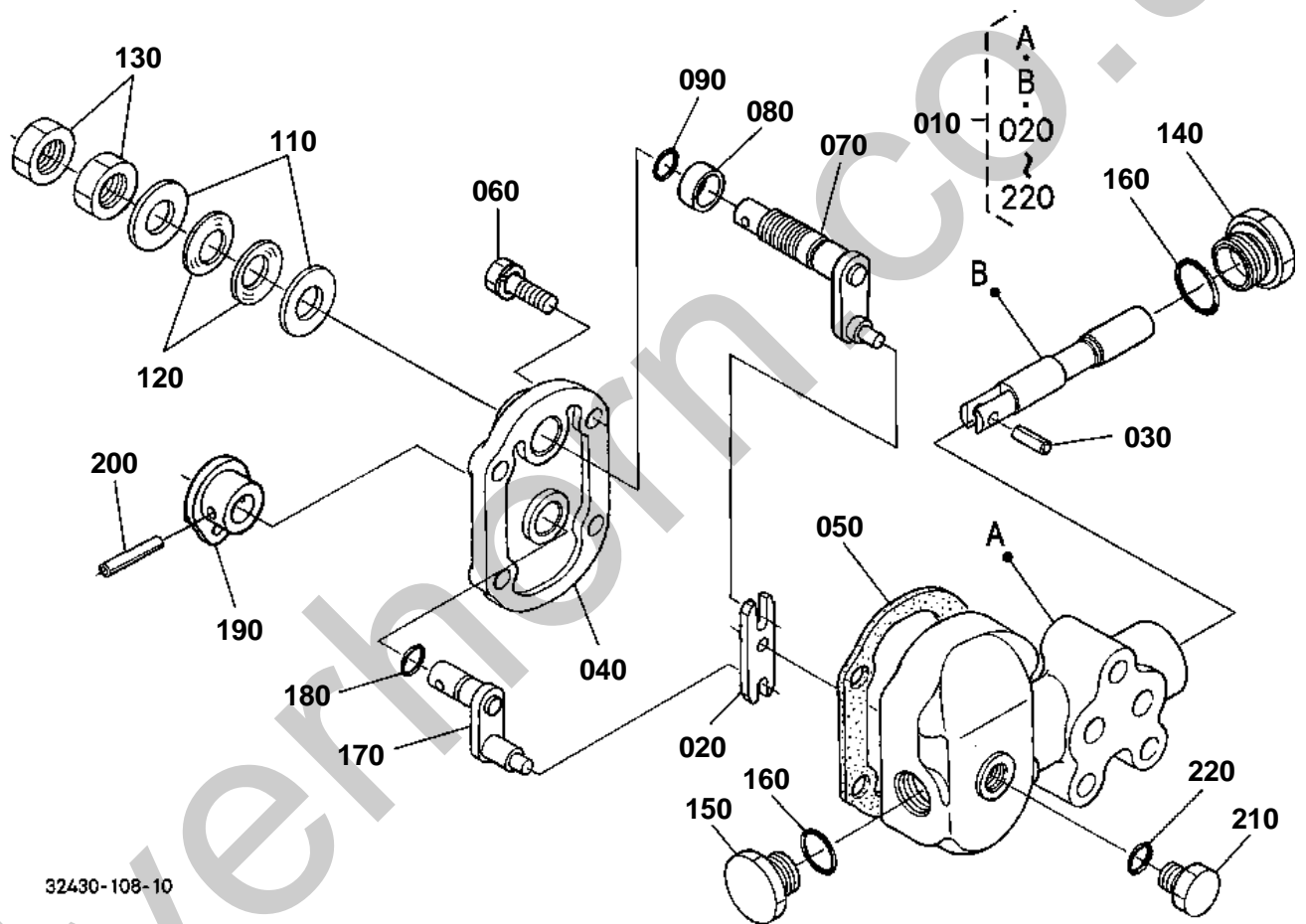

32430-108-10

**DRAFT CONTROL VALVE (WITH DRAFT) [COMPONENT PARTS] [OPTION]**

↔ Interchangeable; ≠ not interchangeable; ← new for old; → old for new

REF.No	Part No.	Description	Q'ty	S.No.	I/C	REMARKS	Weight (kgf)	Weight (lb)
010	35080-41100	ASSY VALVE DRAFT CON	1				2.5	5.5
020	35080-41130	LEVER SPOOL DRIVE	1				0.02	0.044
030	05411-00614	PIN SPRING	1				0.002	0.0044
040	35080-41140	COVER VALVE	1				0.39	0.858
050	35080-41150	GASKET	1				0	0
060	01123-50830	BOLT	4				0.015	0.033
070	35080-41160	ARM CONTROL	1				0.09	0.198
080	35080-41270	COLLAR	1				0.015	0.033
090	04816-06100	O RING	1				0.001	0.0022
100	99999-99999	BLANK	0				0	0
110	04013-60140	WASHER PLAIN	2				0.01	0.022
120	37300-41280	SPRING PLATE	2				0.005	0.011
130	02172-50140	NUT	2				0.01	0.022
140	35080-41170	PLUG	1				0.04	0.088
150	35080-41230	PLUG	1				0.06	0.132
160	04816-00180	O RING	2				0.002	0.0044
170	35080-41180	ARM FEED BACK	1				0.05	0.11
180	04816-00090	O RING	1				0.001	0.0022
190	35080-41190	LEVER FEED BACK	1				0.05	0.11
200	05411-00520	PIN SPRING	1				0.002	0.0044
210	35080-41280	PLUG	1				0.025	0.055
220	04816-00110	O RING	1				0.001	0.0022

TOP LINK HOLDER (WITH DRAFT) [OPTION]

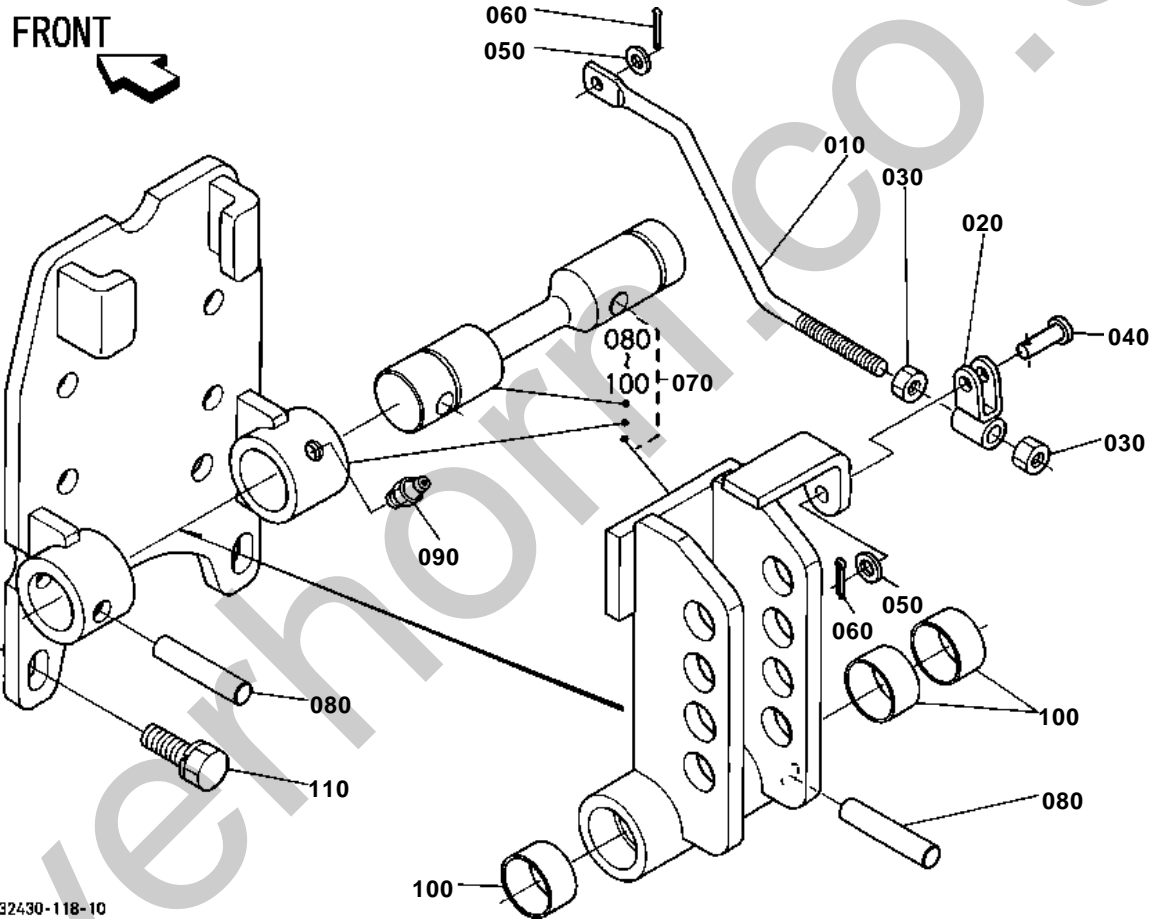



# TOP LINK HOLDER (WITH DRAFT) [OPTION]

↔ Interchangeable; ≠ not interchangeable; ← new for old; → old for new

REF.No	Part No.	Description	Q'ty	S.No.	I/C	REMARKS	Weight (kgf)	Weight (lb)
010	35080-41312	ROD DRAFT CONTROL	1				0.095	0.209
020	35260-41320	HOLDER CONTROL	1				0.03	0.066
030	02112-50080	NUT	2				0.003	0.0066
040	05122-50818	PIN JOINT	1				0.008	0.0176
050	04012-50080	WASHER PLAIN	2				0.001	0.0022
060	05511-50218	PIN SPLIT	2				0.001	0.0022
070	35080-41400	COMP HOLDER TOP LINK	1				6.85	15.07
080	37300-41440	PIN STRAIGHT	2				0.055	0.121
090	06613-10010	NIPPLE GREASE	2				0.006	0.0132
100	37300-41450	BUSH	3				0.03	0.066
110	01133-51230	BOLT	6				0.04	0.088

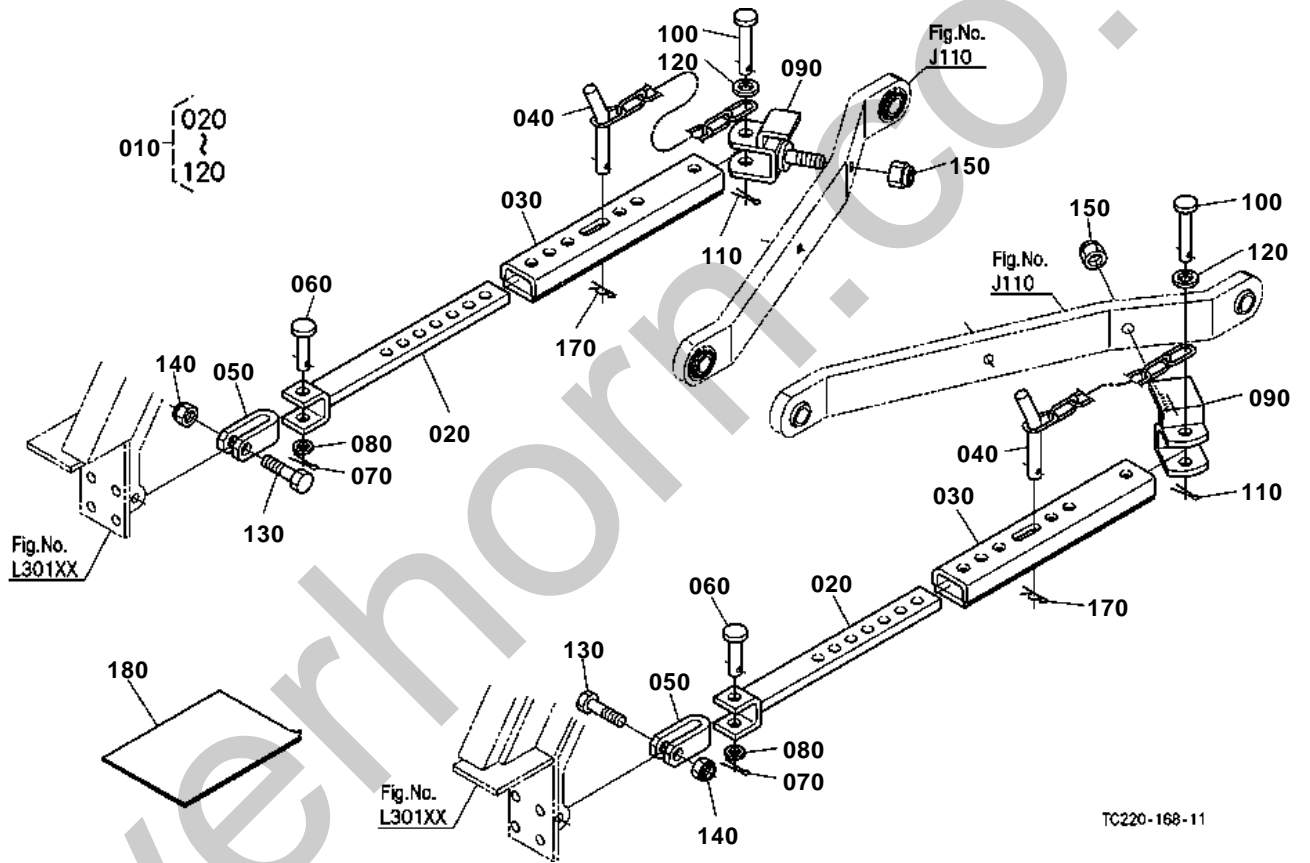

TC220-168-11

**STABILIZER(W/G No.L8430) [OPTION]**

↔ Interchangeable; ≠ not interchangeable; ← new for old; → old for new

REF.No	Part No.	Description	Q'ty	S.No.	I/C	REMARKS	Weight (kgf)	Weight (lb)
010	TC020-39700	ASSY STABILIZER	2				2.7	5.94
020	TC020-39710	BRACKET STAB.FRONT	2				0.9	1.98
030	TC020-39720	BRACKET STAB.REAR	2				0.9	1.98
040	TC020-39730	PIN STABILIZER	2				0.2	0.44
050	TC020-39740	BRACKET STABILIZER	2				0.155	0.341
060	05122-51050	PIN JOINT	2				0.032	0.0704
070	05511-50325	PIN SPLIT	2				0.002	0.0044
080	04011-50100	WASHER PLAIN	2				0.002	0.0044
090	TC020-39750	BRACKET STAB.REAR	2				0.435	0.957
100	05122-51255	PIN JOINT	2				0.051	0.1122
110	05511-50425	PIN SPLIT	2				0.003	0.0066
120	31351-71670	WASHER PLAIN	2				0.002	0.0044
130	TC020-39850	BOLT STABILIZER	2				0.03	0.066
140	02576-50100	NUT LOCK	2				0.006	0.0132
150	02574-50160	NUT LOCK	2				0.03	0.066
160	99999-99999	BLANK	0				0	0
170	05515-61000	PIN SNAP	2				0.002	0.0044
180	99999-99999	MANUAL INSTRUCTION	1				0	0

SWINGING DRAWBAR [OPTION]

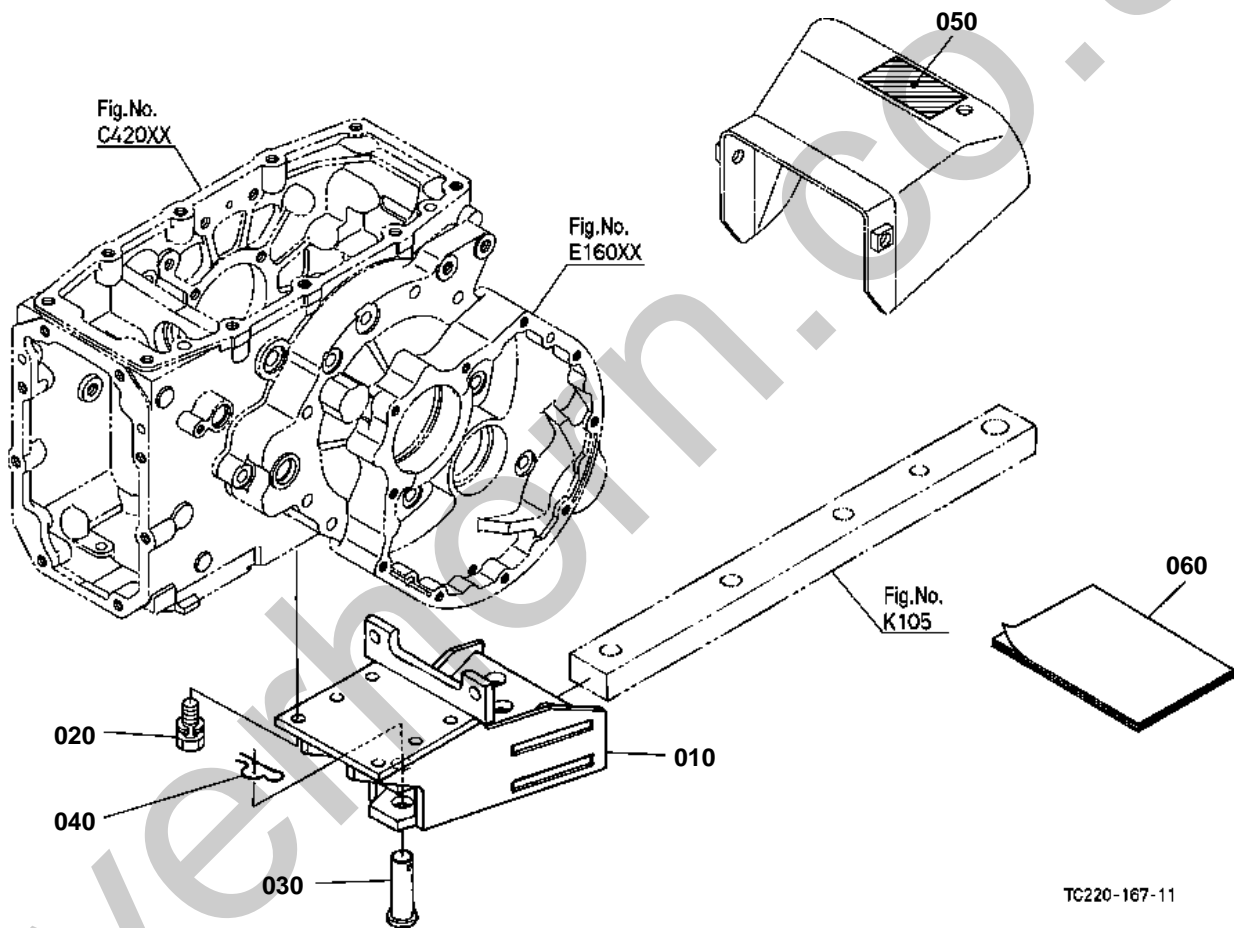

TC220-167-11



## SWINGING DRAWBAR [OPTION]

↔ Interchangeable; ≠ not interchangeable; ← new for old; → old for new

REF.No	Part No.	Description	Q'ty	S.No.	I/C	REMARKS	Weight (kgf)	Weight (lb)
010	32430-29730	FRAME DRAWBAR	1				7.85	17.27
020	01133-51430	BOLT	6				0.001	0.0022
030	05122-52070	PIN JOINT	3				0.184	0.4048
040	05515-51600	PIN SNAP	3				0.007	0.0154
050	35260-25340	LABEL PTO WARNING	1				0.005	0.011
060	32430-98510	MANUAL INSTRUCTION	1				0.01	0.022



T/M OIL EXTENSION PORT AND GAUGE KIT

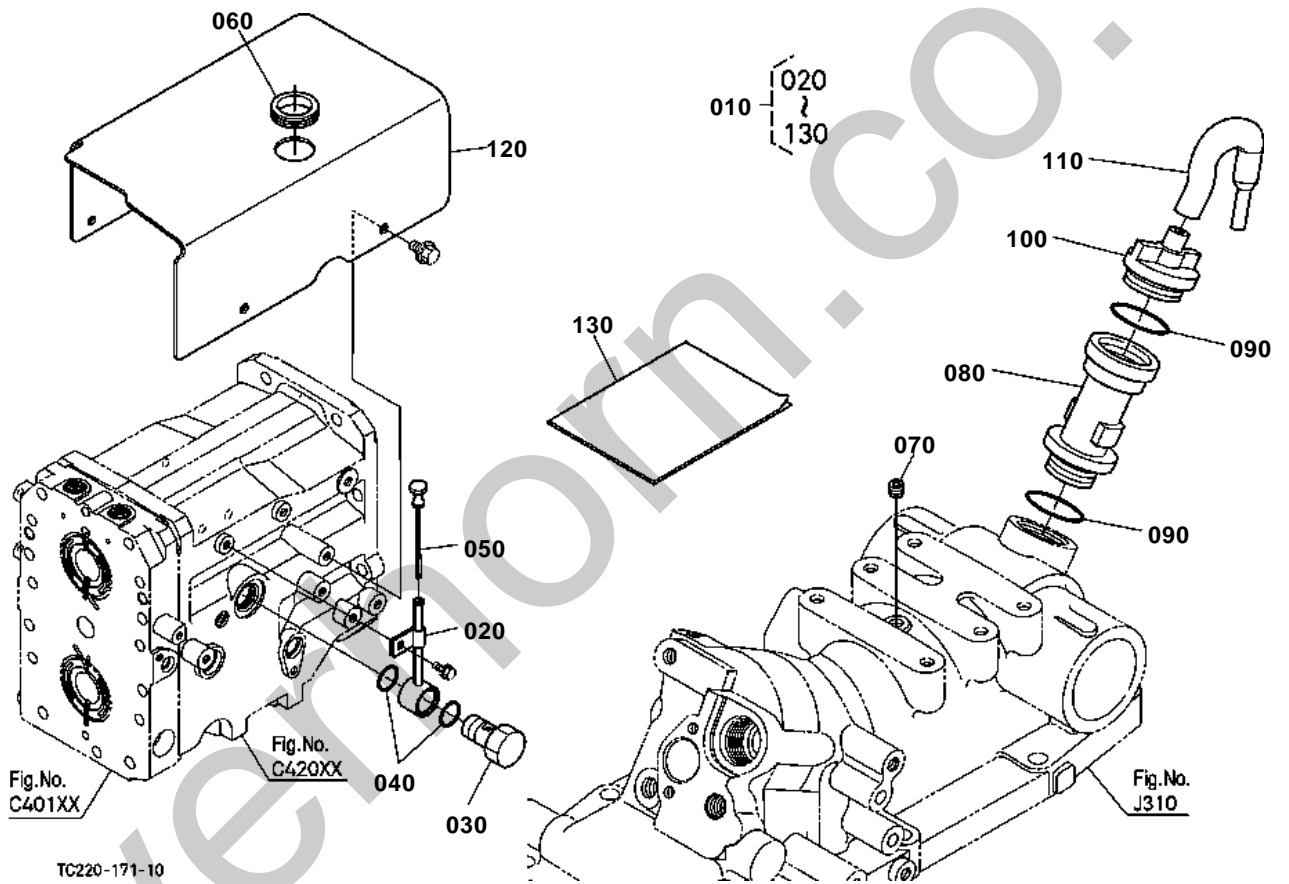



# T/M OIL EXTENSION PORT AND GAUGE KIT

↔ Interchangeable; ≠ not interchangeable; ← new for old; → old for new

REF.No	Part No.	Description	Q'ty	S.No.	I/C	REMARKS	Weight (kgf)	Weight (lb)
010	TC220-99680	KIT OIL GAUGE	1				0	0
020	TC220-56510	GUIDE OIL GAUGE	1				0	0
030	TC220-56520	BOLT JOINT	1				0	0
040	04817-05310	O RING	2				0.001	0.0022
050	63763-11460	GAUGE OIL	1				0.011	0.0242
060	32530-31180	RING RUBBER	1				0.005	0.011
070	06312-10010	PLUG	1				0.007	0.0154
080	15224-33110	FLANGE OIL FILLER	1				0.158	0.3476
090	04816-50300	O RING	2				0.001	0.0022
100	38180-21410	PLUG	1				0.02	0.044
110	38180-37140	BREATHER	1				0.01	0.022
120	TC220-56530	COVER CENTER	1				0	0
130	TC220-99690	MANUAL INSTRUCTION	1				0	0